

73 - Syracuse Near Westside

Notice

The opinions expressed in this report do not necessarily reflect those of the New York State Energy Research and Development Authority (hereafter “NYSERDA”) or the State of New York, and reference to any specific product, service, process, or method does not constitute an implied or expressed recommendation or endorsement of it. Further, NYSERDA, the State of New York, and the contractor make no warranties or representations, expressed or implied, as to the fitness for particular purpose or merchantability of any product, apparatus, or service, or the usefulness, completeness, or accuracy of any processes, methods, or other information contained, described, disclosed, or referred to in this report. NYSERDA, the State of New York, and the contractor make no representation that the use of any product, apparatus, process, method, or other information will not infringe privately owned rights and will assume no liability for any loss, injury, or damage resulting from, or occurring in connection with, the use of information contained, described, disclosed, or referred to in this report.

NYSERDA makes every effort to provide accurate information about copyright owners and related matters in the reports we publish. Contractors are responsible for determining and satisfying copyright or other use restrictions regarding the content of reports that they write, in compliance with NYSERDA’s policies and federal law. If you are the copyright owner and believe a NYSERDA report has not properly attributed your work to you or has used it without permission, please email print@nyserda.ny.gov

Syracuse Near Westside Community Microgrid Feasibility Study

NY Prize Stage 1
NYSERDA Contract #64379



Task 5: Final Report

Project Team: Syracuse University – SyracuseCoE (Project Lead),
Hitachi Consulting, Green Energy Corp., Power Advisors LLC,
Secure Cyber Technology LLC

December 16, 2016

Table of Contents

- Executive Summary 2**
 - Introduction 2
 - Preliminary Design 2
 - Financial Feasibility 3
- Task 1. Development of Microgrid Capabilities 5**
 - 1.1. Minimum Required Capabilities..... 5
 - 1.2. Preferable Microgrid Capabilities 19
- Task 2. Preliminary Technical Design and Configuration 31**
 - 2.1. Proposed Microgrid Infrastructure and Operations 31
 - 2.2. Load Characterization 34
 - 2.3. Distributed Energy Resources Characterization 38
 - 2.4. Electrical and Thermal Infrastructure Characterization..... 53
 - 2.5. Microgrid and Building Controls Characterization..... 55
 - 2.6. Information Technology (IT)/Telecommunications Infrastructure Characterization 56
- Task 3. Assessment of Microgrid's Commercial and Financial Feasibility 58**
 - 3.1. Commercial Viability – Customers 58
 - 3.2. Commercial Viability – Value Proposition..... 66
 - 3.3. Commercial Viability – Project Team 74
 - 3.4. Commercial Viability – Creating and Delivering Value 76
 - 3.5. Financial Viability 83
 - 3.6. Legal Viability 84
- Task 4. Benefit Cost Analysis 92**
 - Project Overview..... 92
 - Methodology and Assumptions 92
 - Results 94
- Conclusions..... 104**
- Appendices 105**
 - Appendix A: Syracuse Near Westside Microgrid Layout Diagram 106
 - Appendix B: Syracuse Near Westside Microgrid One-Line Diagram 107
 - Appendix C: Syracuse Near Westside Nodal Diagrams..... 108
 - Appendix C: Potential Individual Resident Service Block Locations, Population, Households 119
 - Appendix D: Development of Hourly Load Profiles 121

Photo on cover: Syracuse’s Near Westside Neighborhood, viewed from the west, April 2015.

Executive Summary

Introduction

In partnership with an initiative that is revitalizing the Near Westside neighborhood in the City of Syracuse, a team led by Syracuse University assessed the feasibility of an energy microgrid to provide benefits to a community of predominately low-to-moderate income households. The envisioned microgrid was designed to serve six critical facilities—three schools, a firehouse, a police station, and a primary care medical facility—and a diverse mix of public and private facilities, including a public housing complex, a pharmacy, a grocery store, a church, a public broadcasting complex, and private homes. The project leveraged photovoltaic generation that were installed in three redevelopment projects in the community, and it explored a mix of natural-gas-fired generation and additional solar power supported by energy storage systems. The envisioned microgrid is judged to be feasible technologically and financially; successful development shows potential to catalyze a new phase of reinvestment in a Syracuse’s Near Westside neighborhood and to spur microgrid projects in similar urban neighborhoods throughout New York State.

Preliminary Design

The six critical facilities that are envisioned to be served by the microgrid in the Syracuse Near Westside neighborhood are not contiguous. As a result, the proposed solution uses a distributed microgrid approach that has been developed by team members to improve resiliency in other communities across the country. The approach involves three steps: 1) organize clusters of nearby critical facilities into microgrid “nodes,” within which reliability and resiliency objectives are optimized; 2) coordinate all microgrid nodes to optimize economics and emissions reduction across the entire community; and 3) size the total energy resource portfolio to support additional “neighborhood community locations” (NCLs) in the event of a grid outage that occurs outside the community. In this approach, if there is a grid loss within the community, service to NCLs will be lost, but the microgrid nodes will continue to serve the critical facilities.

The preliminary design for the envisioned microgrid includes six nodes. Four of the nodes serve single facilities: two schools, a firehouse, and a large multi-tenant commercial building that includes a neighborhood police station. Two nodes are envisioned to serve dense clusters of commercial and residential facilities; these nodes each are envisioned to include new dedicated interconnections between adjacent facilities. In addition to the six nodes, the microgrid is envisioned to include in-front-of-the-meter “Neighborhood Energy Resources (NERs)” that are proposed to serve facilities throughout a large portion of the Near Westside neighborhood using existing electrical distribution infrastructure.

Following the team’s Microgrid Research Portfolio Approach, the Syracuse Near Westside microgrid nodes are designed to provide for 80% to 86% of the node customers’ energy supply from on-site resources, with the remainder of the energy provided by the grid when the grid is operating. The microgrid treats the utility grid as an additional resource, and includes reliability history of the grid into reliability optimization.

The envisioned system includes 600 kW in new power generation from photovoltaics (PV). Combined with 138 kW in existing solar PV, this represents a displacement of about 1.28% of the electric load from the grid. The microgrid will also include approximately 5,600 kW in CHP generation, displacing 80.64% of the electric load from the grid. CHP heat recovery will result in the recovery of about 25.5 million kBtu that will supplant about 28% of the existing 92 million kBtu thermal load in the microgrid. Energy storage of 135kW/270 kWh will be included. The proposed system would also produce 7,911 fewer tons of carbon dioxide each year, due to an emissions profile that is much cleaner than that of the utility.

Financial Feasibility

The project team developed a general budget for the Syracuse Near Westside Community Microgrid project and incorporated it into the technical model to ensure that the design meets both the technical and economic requirements of the project. This budget includes costs for engineering, permitting, capital equipment, site preparation, construction, controls, start-up, commissioning, and training. The cost associated with “site preparation” includes the addition and modification of electrical infrastructure, PCC controls, monitoring, and protection equipment. Some of these infrastructure costs may be paid to the electric utility. The estimated project budget for this project is \$12.6 million with an accuracy of +/- 25%. This cost includes all applicable deductions associated with the federal investment tax credit (ITC) that was recently extended by the US Congress. Excluding the ITC, the project cost would be \$13.5 million. (This cost does not include other incentives that may be applicable to the project that would be evaluated during subsequent detailed analysis of the envisioned microgrid.)

The outputs of the technical modeling process were used to evaluate the financial viability of the proposed microgrid from two perspectives. First, the project team analyzed the financial strength of the project when deployed using the proposed third-party ownership business model. Under this model, the project is funded through outside investment and debt which is recouped through power purchase agreements (PPAs) with each facility. In addition, NYSERDA contracted with Industrial Economics, Incorporated (IEc) to perform a benefit-cost analysis. The focus of this analysis is to evaluate the societal benefit of the microgrid, including benefits from emissions reductions, cost reductions, and resilience improvements.

Business Model Financial Results

Under the envisioned business model, a third party would fund all development and construction of the microgrid, own and operate the assets, and sell the energy generated from the microgrid to community customers through PPAs. The community would incur no costs to build the project and would receive all of the benefits of energy resilience during a grid outage, and improved sustainability. Community stakeholders have indicated that third party ownership of the microgrid is currently the preferred ownership structure. The current weighted electric rate of the key critical facilities included in the proposed microgrid is approximately \$0.0916/kWh.

Benefit-Cost Analysis Results

NYSERDA contracted with IEc to conduct an independent benefit-cost analysis. The project team provided detailed information to IEc to support this analysis. IEc ran two scenarios for this proposed microgrid. The first scenario modeled no power outages, and evaluated the grid connected mode of operation. The second scenario modeled the number of days (or partial days) outage at which the costs of the microgrid would be equal to its various benefits, thus yielding a cost benefit ratio of 1. For the Syracuse Near Westside Community Microgrid, the breakeven outage case is one outage per year for a duration of a quarter of a day. The cost benefit results are presented in Table 1.

Executive Summary Table 1 – Cost Benefit Analysis Results

Economic Measure	Assumed average duration of major power outages	
	Scenario 1: 0 DAYS/YEAR	Scenario 2: 0.23 DAYS/YEAR
Total Benefits - Present Value	\$60,400,000	\$63,000,000
Total Costs – Present Value	\$63,000,000	\$63,000,000
Net Benefits – Present Value	-2,550,000	30,100
Benefit-Cost Ratio	0.96	1.0
Internal Rate of Return	2.7%	4.9%

This benefit-cost analysis differs from the financial feasibility analysis performed by the project team in several ways. In addition to the differing objectives of these two analyses, the underlying assumptions used in each also differed. A few of these differences affected the results of these analyses in significant ways, including:

- Gas rates used in IEC's benefit-cost analysis were based on a state-wide average for commercial end-use customers. The rates used in Syracuse's financial feasibility analysis are based on National Grid's distributed generation rate. This resulted in year 1 gas rates of \$6.34 and \$4.86, for the benefit-cost analysis and the financial feasibility analysis, respectively. If National Grid's distributed generation rate were applied to the benefit-cost analysis, net benefits would be increased by \$6.1M.
- The financial feasibility assessment incorporates the tax benefits of the Federal Investment Tax Credit, whereas the benefit-cost analysis does not. This benefit reduces the capital cost of the project by \$943,000.
- The benefit-cost analysis derives a price for electricity based on average wholesale energy costs, whereas the financial feasibility assessment evaluates the savings to the community based on actual costs paid by community participants.
- The period of analysis in the benefit cost analysis is 20 years and the third party ownership model is based on a period of analysis of 25 years.

The project team believes that this project is technically and financially feasible. The project substantially aids the State of New York in meeting many of its policy goals. Additionally, such a project would provide resilience and the opportunity for environmentally sustainable economic development in the Near Westside neighborhood. While the financial feasibility for the Near Westside Microgrid project is viable, additional funding will almost certainly be needed to make the project financially competitive. Community stakeholders anticipate that the full-system design of a microgrid for Syracuse's Near Westside neighborhood will be led by the Hitachi Microgrid Solutions Business.



In 2010, the Near Westside Initiative engaged New York City artist Steve Powers to address the physical barrier created by three railroad overpasses that define the northeast corner of the neighborhood. Powers previously had developed installations of "love letters" painted on railroad bridges in Brooklyn, Philadelphia, and other locations. For the Near Westside project, Powers listened to how residents describe their neighborhood and he developed messages that reflected what he heard. The photo above shows the message Powers painted on the west face of the overpass above W. Fayette St. Previously, this overpass had a rusty, faded ad that included a depiction of a light bulb (for a local auto dealer that "has a better idea"). By incorporating depictions of incandescent and compact florescent light bulbs in the new message, Powers' intent was to connect past and future generations in the community (including recalling when residents paid "the light bill").

Task 1. Development of Microgrid Capabilities

1.1. Minimum Required Capabilities

This section outlines the minimum required capabilities of a community microgrid that is envisioned to serve Near Westside neighborhood in the City Syracuse. The approach to the envisioned microgrid architecture and design described here incorporates lessons learned and best practices from other microgrid projects that Project Team members have designed and developed (e.g., Olney Town Center in Maryland). In addition, the approach is consistent with approaches that are proposed for multiple other NY Prize projects in which some members of the Project Team participated in, creating opportunities for potential economy-of-scale savings in subsequent design and implementation phases of the NY Prize program.

The Near Westside Community microgrid design is focused on the development of an overall energy strategy that incorporates both demand-side management and new distributed generation resources to support the microgrid operational objectives. The microgrid operational objectives are to simultaneously improve resiliency, increase energy efficiency, spur economic development, lower environmental emissions, and lower cost to energy users.

Syracuse's Near Westside neighborhood was selected for this microgrid feasibility study because it includes a combination of challenges and demonstration opportunities that are common in many post-industrial urban communities throughout New York State. The 550-acre mixed-use Near Westside neighborhood is adjacent to downtown, as depicted in Figures 1.1 and 1.2.

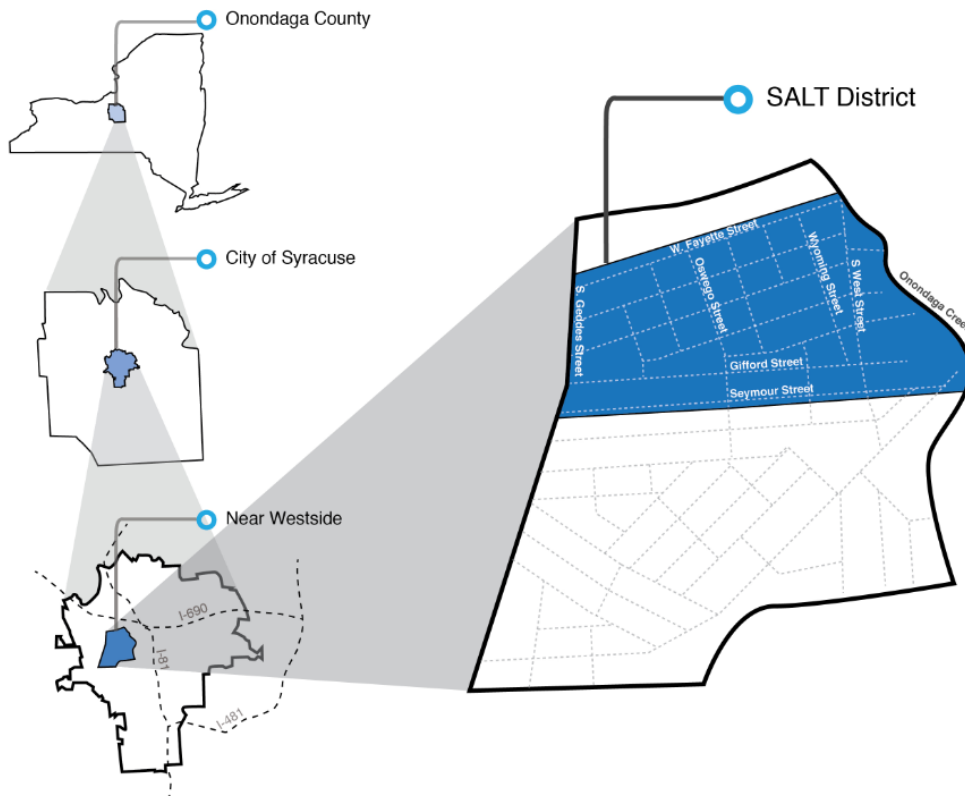

Figure 1.1 – Location of Near Westside Neighborhood and SALT District within City of Syracuse and Onondaga County



Figure 1.2 – Syracuse’s Near Westside Neighborhood, viewed from the south, September 2007.

Like many other urban neighborhoods across Upstate New York, Syracuse’s Near Westside experienced growth, vibrancy and resilience from the opening of the Erie Canal in 1825 until after the end of World War II. Since 1950, the Near Westside Community experienced decades of disinvestment as jobs and families moved out of the city to Syracuse’s growing suburbs and beyond. By 2000, Syracuse’s Near Westside Community had become one of the most economically distressed communities in the United States, with hundreds of vacant properties, the vast majority of the building stock in extremely poor condition, and 50% of its residents below the poverty level.

Beginning in 2007, the Near Westside Initiative (NWSI) engaged residents and developed a series of projects designed to revitalize the neighborhood. The mission of the NWSI is “to art, technology, and innovation with neighborhood values and culture to revitalize Syracuse’s Near Westside.” To date, the NWSI has strategically focused on projects in the northern one-third of the Near Westside neighborhood, which is adjacent to the vibrant “Amory Square” district in downtown Syracuse. Through the initiative, the northern third of the Near Westside (north of Seymour Street) has become known as the “Syracuse Art, Literacy, and Technology (SALT) District” (shown in Figure 1.1).¹ To date, more than \$70 million in private and public investments has been attracted the SALT District, including renovation, adaptive reuse, and new construction projects.

Right from the start, a key strategic approach of the NWSI was to pursue and implement best practices for green building design and construction. SyracuseCoE led these efforts, working in close partnership

¹ See <http://www.saltdistrict.com/>



Figure 1.3 — Three adaptive reuse projects in the northeast corner of the Near Westside include a total of 138kW of existing solar photovoltaic generation that was included in the design of the envisioned microgrid: 1) WCNY, top (95 kW); 2) Lincoln Supply, left (31 kW); and 3) King+King, right (12 kW).

Home HeadQuarters many SyracuseCoE partner firms to complete a wide variety of projects. Accomplishments to date include:

- First in the country to earn certification (Gold) under the LEED for Neighborhood Development rating system for a redevelopment plan for an existing neighborhood.
- Assistance provided to residents to improve energy efficiency in more than 30 owner-occupied single family homes.
- Design and construction of three high-performance single-family homes, and the subsequent monitoring of energy use in these homes over a three-year period. (All three homes earned LEED-H certifications: two Platinum, one Gold; one home achieved Passive House certification.)
- Assistance provided in design of three adaptive reuse projects shown in Figure 1.3: 1) King+King Architects, 2) Lincoln Supply, and 3) WCNY. (Each of these projects includes installations of solar photovoltaic systems totaling 138kW that were incorporated into the design of the envisioned microgrid.)

1.1.1 Serves Critical Facilities

The study evaluated the feasibility of a microgrid that is envisioned to serve six critical facilities: three schools, a firehouse, a police station, and a primary care medical facility. In addition, the envisioned microgrid was designed to serve a diverse mix of public and private “community partners,” including: a public housing complex, a pharmacy, a grocery store, a church, a public broadcasting complex, several community service organizations, in addition to private residences in the broader Near Westside neighborhood. The critical facilities and community partners are shown in Figure 1.4.

In considering impacts of grid outages on the neighborhood, it is important to consider that many of the 876 residents of the James Geddes Housing Development of the Syracuse Housing Authority (SHA) are vulnerable elderly and/or disabled residents who have limited options for self-evacuation in the event of an extended grid outage or a major storm. Thus, it is important to support sheltering in place and the provision of essential services for many days, which means the need for resilient, police, fire, and

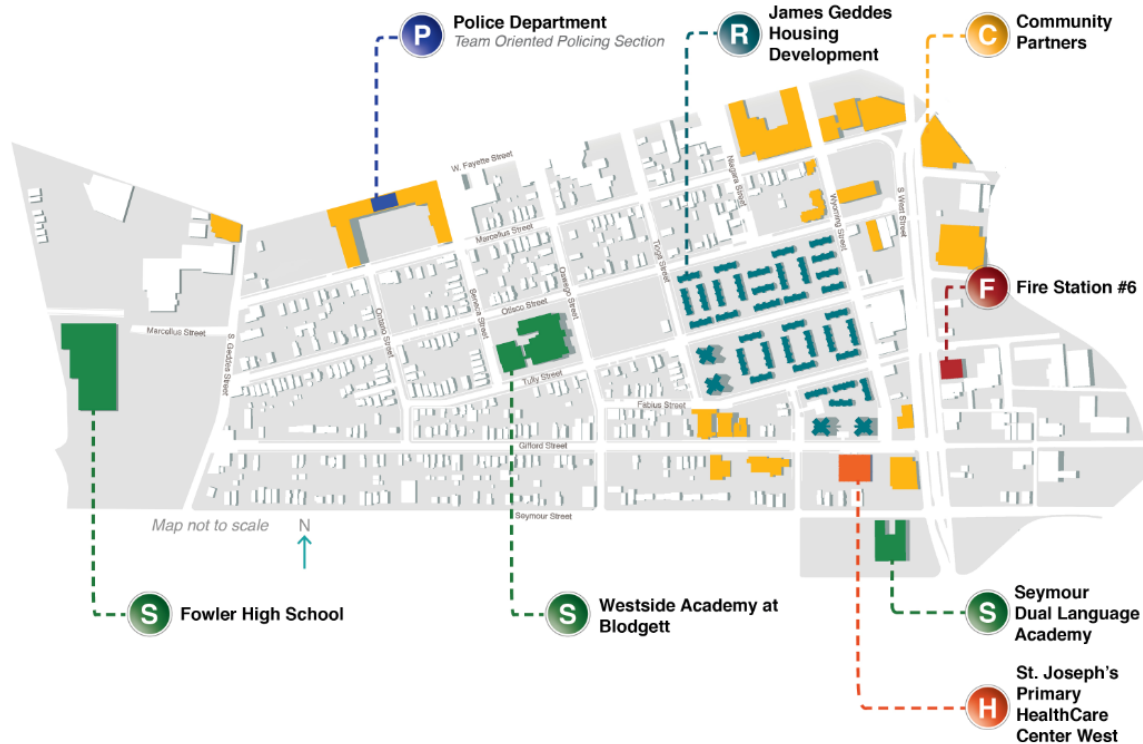

Figure 1.4 — Critical facilities and community partners in proposed microgrid.

emergency medical services. Plus, in an extended outage or storm aftermath, the need to replenish groceries, prescriptions, and other critical services become very important to sustain a community.

1.1.2 Primary Generation Resources

Generation sources in the microgrid were expected to include natural-gas-fired (NG) and photovoltaic (PV) generation resources, supported by energy storage systems (ESS). Wherever feasible, natural-gas-fired generation was designed to be located at sites that can make productive use of available thermal energy to create economically and thermally efficient combined heat and power (CHP) systems. At the outset, the initial microgrid plan expected generation capacity to total approximately 2 MW, with approximately 1 MW from NG resources and 1 MW from PV resources, supported with 350 kW of energy storage. This initial expectation was refined through the design evaluation in Tasks 2 and 3 of the feasibility assessment.

1.1.3 Power in Grid-Connected and Island Modes

Critical facilities in U.S. communities are typically dispersed and often served by separate distribution feeders with limited or no load transfer capability. Typically there is no distribution automation available to facilitate back up of essential services. This familiar situation is the case in the Near Westside community. Developing a nodal approach to the microgrid is expected to yield the greatest potential benefit. In this approach, cost-effective options for resilient microgrids will serve multiple critical and vital community assets that are widely dispersed and not conveniently concentrated on a single distribution feeder. Consequently, the Project Team believes that a “nested microgrid” configuration is the most efficient way to support the Near Westside Community’s resiliency requirements. “Nested microgrid” refers to the placement of microgrid resources at geographically dispersed critical facilities that are operated as separate nodes in the microgrid.

NG fuel cells, microturbines, and CHP units are usually not designed to follow customer load. However, with de-rating of units, it is practiced. The danger of misapplying such resources is that these resources are not designed for the ramp rates needed to follow load. Thus, if the resources were to follow load, they might respond in ways that damage the equipment. In addition, emissions per MWh and maintenance costs can increase dramatically by sub-optimal use. Finally, some vendors will void warranties when units that are designed to provide base load are used as load-following units.

To better match the load profile, the optimal approach is to reduce the size of the CHP to the size that will economically operate at design output for at least 8,000 hours per year. This means that for a majority of the day the electrical load and CHP generation are closely coordinated. To meet the daytime peak customer load it is preferable to use a generation resource with a profile similar to the load, such as PV. Since energy storage can be designed to change its output rapidly and address the ramp rate issue, ESS can be used to follow load and to buffer the differences between CHP, electrical load, and PV throughout the day. Also, it is very important to consider the thermal load, including thermal energy storage and existing boiler operations, to address the ramping requirements of the thermal load.

From the long-term operations and maintenance standpoint, the Resource Portfolio Concept enables the microgrid to use its resources within their design envelope, which helps keep maintenance costs and fuel costs at their minimum, making the total cost of ownership as low as possible. Further, the active microgrid controls enable optimal incorporation of energy efficiency measures, energy storage, PV, and building management systems to control load in such a way to reduce the afternoon peak load when needed, as depicted in Figure 1.5.

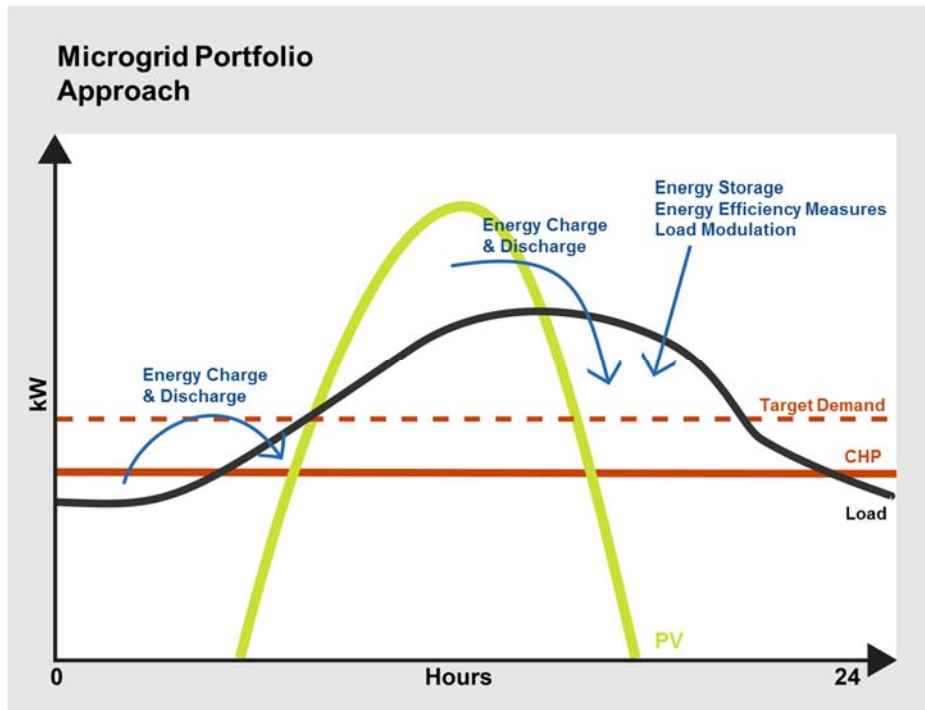

Figure 1.5 – Area of Interest for Active Management of Load

The benefit of the Resource Portfolio Concept is to enable the microgrid resources to serve the nodal microgrid loads more efficiently, more cost effectively, and with a lower emissions per unit of energy consumed.

From Figure 1.4, it can be seen that only a few hours per year are at the peak demand for critical facilities in the community. This means all the critical facility services can be provided by the “always-on” microgrid resources for the vast majority of hours in a year without over-building. In essence, the resiliency provided by the microgrid is consistent with favorable economic and emissions performance as compared to traditional approaches where thermal and electrical needs are satisfied independently of each other.

Even when the utility grid is lost, the impact on critical facility services is minimized because the utility grid represents a small portion of the energy supply to the critical facility in grid-connected mode.

Each nested node employs the approach outlined in Figures 1.5 and 1.6. The systems will be coordinated in their operation with each other by a proven microgrid controller. This sophisticated active microgrid control system will ensure that each node is being optimized for resiliency on a local nodal basis. The same software will be used to manage all nodes in the microgrid as a fleet for optimizing economics and minimizing emissions overall. The production and consumption balance of energy will be managed across the utility distribution system. The additional resiliency needed to protect the public will be available in islanding mode operation of the microgrid controller. The result is local improved resiliency and global economic and emissions reduction.

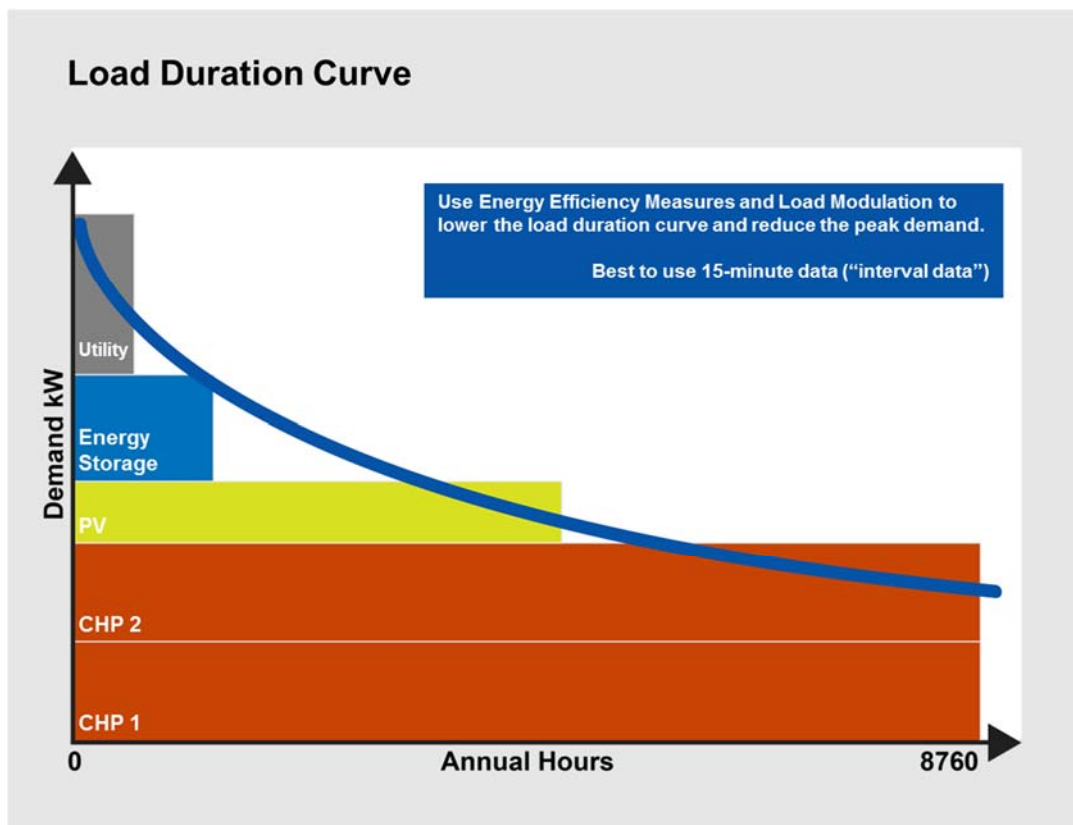

Figure 1.6 – Load Duration Curve

In addition to this nested microgrid design, the Project Team plans for a distributed energy overlay to serve the entire community’s non-critical loads (businesses and residences). The plan includes a NG distributed generation station nearby on the distribution feeder side of the substation transformer to

serve the community's non-critical loads. If grid outages occur outside the community, but the community's distribution grid is unaffected, the distributed generation station will continue to supply the needs of the non-critical loads (as well as the small grid portion of the critical facilities). If the community's distribution grid is affected, the critical facilities will still be powered by the nested microgrid.

1.1.4 Form Intentional Island

In 2014, the Electric Power Research Institute (EPRI) and Oak Ridge National Laboratory (ORNL) collaborated to develop a set of ten Microgrid Use Cases². EPRI/ORNL Use Case Number 3 is Intentional Islanding. For each microgrid, the islanding process will be semi-automatic so that a utility operator or local energy manager will be able to step through each operating step and resiliency preserving option before opening the point of common coupling (PCC), which is the point where each microgrid node connects to the utility grid. The utility operator will provide the appropriate permissive for opening the PCC. The local microgrid controller for each microgrid and microgrid node will be responsible for determining the voltage source and load following resource for transitioning to an island mode.

Island mode operation, in general, is the key to community resiliency in the face of a power system disturbance due to major storms. There is not a reasonable safe evacuation expectation for the Near Westside Community during major storms and/or extended grid outages. This means that more critical services are necessary in extended events and outages, beyond simply providing energy to police, fire, and emergency services. Island operation is necessary in a 4-day outage, much shorter than the 13-day outages experienced in New York State in recent years.

Services, and hence their criticality, are time-variant during a power system disturbance. Police, fire, and emergency medical services are critical from time zero in a major storm and/or extended outage, yet other services become critical with time. Having the community without food re-supply and fresh water for a few hours is not critical, but within 24 hours such services become necessary.

After a couple days, pharmacies become critical for prescriptions, groceries to re-supply residents, places to charge cell phones, etc. After four days, gas stations for refueling vehicles and banks and ATMs for cash become critical, but this need is not currently addressed. Currently, the approach for life support customers is to load shed and relocate or serve in place (via portable generation).

One approach is to take the critical load to the minimum supportable load by the installed microgrid at the beginning of the event and add services as temporary generation can be brought to the community. This inverted approach can complicate relief and recovery efforts as it more quickly draws down essential services from the beginning of the event. In addition, adding back services into the community will be extremely dependent upon the inventory of temporary generation. In a major event, it will not be just the Near Westside Community inhabitants seeking such generation, but hundreds of other communities also vying for the services.

A second approach is to supply the critical load at its typical level at the beginning of the event and enable the critical services that keep the community functioning at an "80% level" through the entire event duration. This reduces the load on police, fire, and emergency services, as well as keeping the community off the streets and open to recovery efforts. Since there is no need for temporary generation trying to be shared across many communities, there is no risk of insufficient generation days into the

² The EPRI/ORNL Microgrid Use Cases can be found at the following URL:

<http://smartgrid.epri.com/Repository/Repository.aspx>

event. The second approach is the recommended resiliency microgrid approach for the Near Westside Community.

The process of islanding a microgrid can create a transient and add risk to operations. To minimize this, the Project Team recommends a specific design approach to the PCC to the utility grid. Figure 1.7 provides a description of the PCC structure.

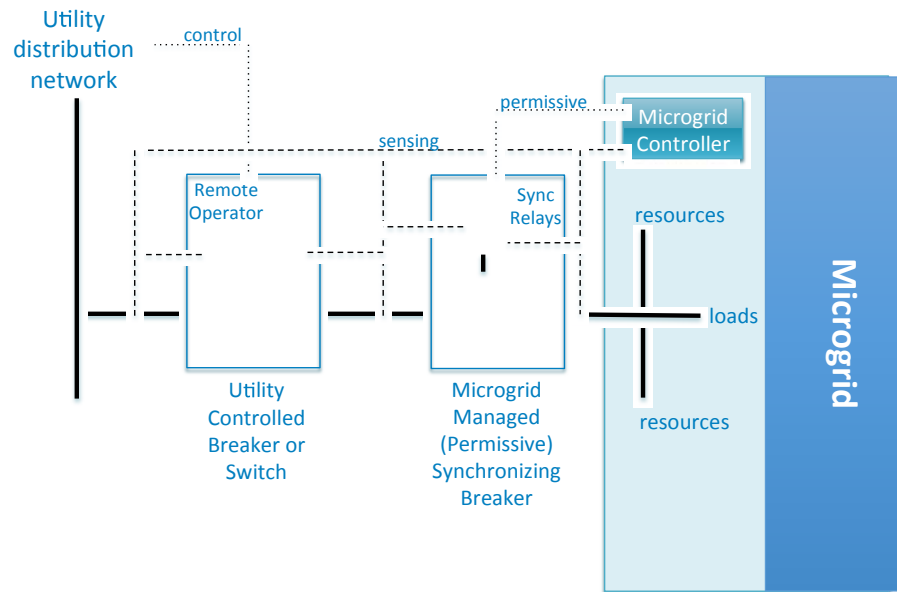

Figure 1.7 – Point of Common Coupling (PCC) Structure

This PCC structure, coupled with additional analysis compliant with IEEE 1547.4, enables the utility-controlled breaker or switch to immediately open (frequency = 59.3 Hz) on loss of the grid. The microgrid managed synchronizing breaker will remain closed for a few more milliseconds until microgrid frequency reaches 57.0 Hz. Since the inverters and generator controls are keying off the synchronizing breaker, these few additional milliseconds enable the energy storage and power electronics to better manage the transient as the microgrid resources pick up the portion of the load served by the utility grid just before the grid was lost. When, or if, the frequency dips to 57.0 Hz and the synchronizing breaker opens, the microgrid is now in an island mode. The microgrid controller will adjust all microgrid resources for the new state and island performance objectives.

In the case where the island transition is too small to generate a transient (such as an intentional island operation), the microgrid controller will open the synchronizing breaker when voltage, frequency, and phase angle are matched and stable across the breaker.

1.1.5 Island from the Grid and Reconnect to the Grid

When islanding from the utility grid, several EPRI/ORNL Use Cases are potentially in action:

1. Frequency control: In normal operations, the microgrid may not have enough resources to affect frequency on the grid. It could participate in ancillary services markets by increasing output to support the frequency in the local grid, but total impact would be small. Nevertheless, the system will monitor frequency along several thresholds – providing a discrete high-low range; the system will detect if frequency is out of range and respond by taking resources off-line, or dispatch other resources to manage frequency. Also, the system will analyze data to detect subtler trends that do not exceed thresholds, but provide evidence of a possible problem.

2. Voltage control: In both grid-connected and islanded modes, the voltage control application will be used to provide stability to the microgrid and connected circuits. Voltage control leverages line sensing and metering to provide control actions when necessary. The application will take into account traditional volt/VAR instruments such as tap changers and cap banks along with inverter-based resources, which should provide a greater degree of optimization.
3. Intentional islanding: For each microgrid node, the islanding process will be semi-automatic so that a utility operator or local energy manager will be able to step through each step before opening the PCC. The utility operator will provide the appropriate permissives for opening the PCC. The local microgrid controller for each microgrid node will be responsible for setting the voltage source and load following resource.
4. Unintentional islanding: For each microgrid node, the islanding process will be automatic as described above.
5. Islanding to grid-connected transition: As with intentional islanding, the utility operator will provide the appropriate permission to close in the PCC. The local microgrid controller will support the reconfiguration of each dispatchable resource.
6. Energy management: This is the most complex Use Case. Its design incorporates a portfolio of resources. The Use Case takes a traditional energy management approach, including economic dispatch, short-term dispatch, optimal power flow, and other processes typical in utility control room environments. The microgrid controller will have corresponding applications that manage the set of controllable generation and load assets. Within that portfolio, the system will optimize the microgrid based on load forecast, ancillary services events, changes in configuration, outage of specific equipment, or any other kind of change to determine the optimal use of assets 48 hours ahead.
7. Microgrid protection: This microgrid controller will ensure two primary conditions. The first is that each protection device is properly configured for the current state of the microgrid, either islanded or grid-connected. The second condition is that after a transition the microgrid controller will switch setting or verify that the setting has changed appropriately. In either condition, if the test is false then the controller will issue a shutdown of each resource and initiate the appropriate alarm.

More discussion on the microgrid controls can be found below in Section 1.2.

The sequence of events for transitioning to an island mode is discussed above. The sequence of events for transitioning from an island mode to grid-connected mode is formed in accordance with the EPRI/ORNL Use Case 5. The summary of the transition is as follows:

- Utility determines it is acceptable for the microgrid to reconnect to the grid and closes the utility controlled breaker (see Figure 4).
- Microgrid controller senses voltage, frequency, and phase angle on the bus between the utility controlled breaker and the microgrid synchronizing breaker. The controller also senses voltage, frequency, and phase angle within the microgrid.
- Microgrid controller (and/or operator) decides to reconnect the microgrid to the utility grid.
- Microgrid controller adjusts controllable resources and loads to match voltage, frequency, and phase angle across the microgrid synchronizing breaker. This minimizes differences and power flows.

- When matched, the microgrid controller give a “permissive to close” signal to the microgrid synchronizing breaker.
- The synchronizing breaker does its own checking of voltage, frequency, and phase angle matching, and closes when matched.
- The microgrid controller places some microgrid load on the utility grid, and re-optimizes for economics and emissions reduction.

1.1.6 Scheduled Maintenance Intervals and Utilization of Power

The scheduled maintenance for high-efficiency natural gas engine-based CHP systems typically requires a quarterly routine maintenance session (< 6 hours) plus an annual routine maintenance session (< 1 week). These CHP systems typically demonstrate full power operations above 8,500 hours per year.

The scheduled maintenance for the PV is an annual cleaning. Our Team’s experience in California with PV is that solar panel surfaces foul to a 97% production level within 3 weeks of surface cleaning. Therefore, cleaning does not provide a significant difference in annual production. The annual cleaning is more about observing anything unusual in or around the installation.

The scheduled maintenance for the energy storage systems is a quarterly routine inspection of the units. The condition of the units is monitored and trended continuously during operations, which drives all maintenance based on trends in conditions. The scheduled maintenance is primarily an external inspection for environmental conditions that may impact the lifetime of the energy storage systems.

The utilization of power available from the distributed energy resources (DER) in the microgrid is the primary driver for optimization. This is why the microgrid concept of operations is energy first, capacity second as described in section 1.1.3 above. Energy storage becomes the most important tool in maximizing the utilization of these generating assets from addressing the inherent intermittency of solar PV to managing total microgrid power factor to 0.98.

Distributed energy storage systems have the ability to serve many roles in a microgrid. This is why ESS is referred to as the “utility infielder” of the microgrid. Properly selected ESS can support many modes of operation:

- Constant Charge
- Constant Discharge
- Peak Shaving
- Load Smoothing
- PV Intermittency
- Load Shifting
- VAr Control
- Voltage Support
- Frequency Support
- Demand Response
- Arbitrage
- Island (voltage source)

The fundamental principle behind the technology is its capability to provide real or reactive power whether it is charging or discharging. Figure 1.8 shows how a community energy storage (CES) unit operates effectively in all four quadrants when commanded to do so. This data is from Green Energy Corp actual testing of a CES unit operating in a community in San Diego.

Figure 1.8 – ESS Four Quadrant Operation

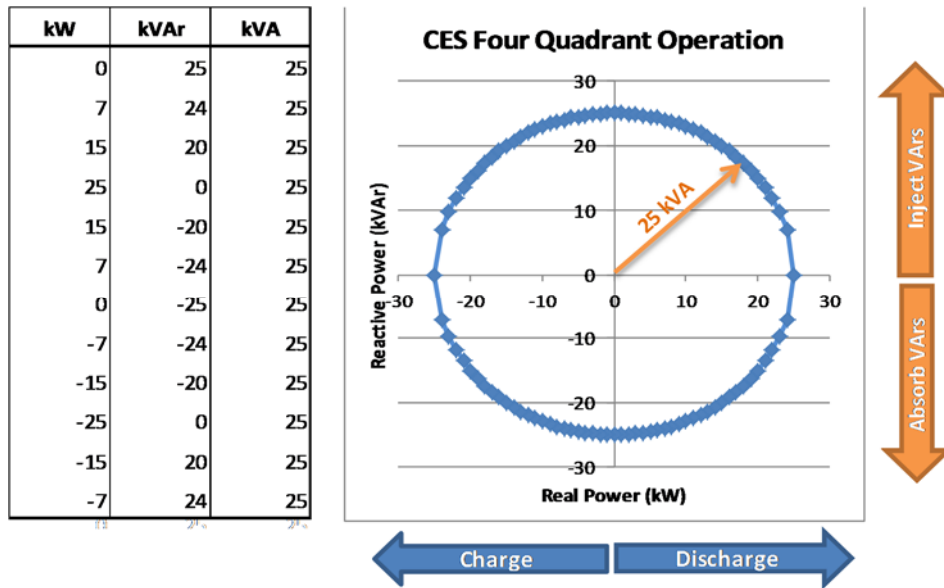

1.1.7 Follow Load and Maintain the Voltage and Frequency

The Near Westside Community microgrid design is focused on the development of an overall energy strategy that incorporates both demand-side management and new distributed generation resources to support the microgrid operational objectives mentioned in the introduction to section 1.1. During operation in the grid-connected mode, the resources will typically be dispatched in an economic optimization mode. This approach will ensure that the microgrid will operate in a manner that the energy delivered to the critical facilities is at or lower than that the cost of electricity that could be purchased from the local utility. In this scenario, the CHP will operate in a constant output mode at its maximum efficiency and lowest emissions, the PV generation profile will be taken into account, the energy storage will operate in a manner to maximize microgrid benefits and the grid will operate in a load following mode. The connection to the grid will also be used to manage the voltage and frequency of the microgrid.

One of the key elements of the microgrid is the ability to operate when the utility grid is not available. The methods of transitioning into an island mode are characterized as either a planned transition or an unplanned transition. In the planned transition, outside information is used to ramp up resources so that there is zero import at the point of common coupling to the microgrid and then to seamlessly transition into island operations at the appropriate time. For the microgrid project, the design requirement will be to size and operate the microgrid resources in island operation for a minimum period of 7 days with a multi-week operation likely. During island mode operation, the microgrid control system must ensure that there is a balance of generation and load in order to maintain system stability including voltage and frequency. To accomplish this, the microgrid controller must be able to provide a load forecast of the critical load, forecast PV generation, and then dispatch resources to match the load. It is anticipated that the resources available to be controlled during the island operations include CHP, fossil fuel generators, PV systems, energy storage, and building load. The microgrid controller will monitor island mode frequency and voltage and adjust equipment operation accordingly to maintain circuit stability. The other key element is the transition back to the grid when the utility service is restored. The design will ensure that the return to the grid is a seamless transition and is coordinated

with the utility through appropriate protocols, safety mechanisms, and switching plans that will be communicated to the microgrid controller by the utility distribution management system.

To support steady-state frequency requirements, as well as the ANSI 84.1-2006 standard voltage requirements, and to support the customer power quality requirements at PCC, the microgrid controller will actively manage the dispatch of generation resources; actively manage the charge and discharge of energy storage; provide observability of microgrid-wide telemetry including frequency, power factor, voltage, currents and harmonics; provide active load management; and provide advance volt-VAR variability algorithms and other stability algorithms based on steady state telemetry of the system.

1.1.8 Two-Way Communication and Control

Communication within the microgrid and external hosted systems requires the use of wired and wireless solutions. Communication types can be classified as both data and control paths. The microgrid controller is agnostic of the communication media and provides a level of data-in-motion security between field devices and external systems. At minimum, two-way communications to support control functions is used. A more flexible communication method is the use of a publish/subscribe middleware to support one to many communications. The communication bandwidth supports dozens of devices communicating every 1 to 10 seconds. In special cases, high frequency measurements, as many as 60 samples per second, can be used for stability applications. In this case, the network is tuned to support this requirement.

Controls are essential in this type of system requiring analog outputs (AO), direct operate (DO), and select-before-operate (SBO) over a reliable messaging layer. Resource levels controls occur as fast as every second for certain periods of time.

An advanced control concept is employed as distributed control logic, also referred to as machine-to-machine communication. This is dependent on the microgrid controller, middleware, and the configuration of the network.

1.1.9 Power a Diverse Group of Customers with Critical Facilities

The critical facilities in the Near Westside community are not contiguous sites, but are feasible with the distributed microgrid approach envisioned by the Project Team. On the east side of the Near Westside Community is a compact cluster of community assets that provided a very promising opportunity for the microgrid. The area includes six facilities that provide critical services to the public: Fowler High School, Westside Academy at Blodgett, Seymour Dual Language Academy, Syracuse Fire Station #6, a Syracuse Police Department team-oriented station, and Saint Joseph's Primary Care Center West. In addition, the area includes a diverse mix of uniquely owned/controlled buildings that have the potential to act as a group of interconnected loads and distributed energy resources. Microgrid participants may include: James Geddes Housing Development, Gifford and West Pharmacy, Nojaim Brothers Supermarket, St. Lucy's Church, WCNY public broadcasting station, Huntington Family Center, CNY Services Homestead Housing, P.E.A.C.E. Inc., Westside Family Resource Center, Hillside Children's Center, King+King Architects, Steri-Pharma, and many single-family homes. In addition, the area includes several vacant or underutilized properties that provide opportunities for attracting investments in new projects as envisioned in the LEED-ND plan for the neighborhood and/or siting distributed generation and microgrid infrastructure.

Baseline electric loads for properties total approximately 10,000,000 kWh annually, with a peak load of approximately 2,000 kW. This will be confirmed in Task 2 of the feasibility assessment. Three of the candidate facilities currently have photovoltaic arrays installed, with total capacity of 143 kW. Likewise, the total annual NG consumption of the candidate properties is approximately 1,000,000 ccf.

1.1.10 Uninterruptable Fuel Supply

Based on field discussions with community stakeholders, the Project Team understands that the gas distribution network in Near Westside can experience low pressures during periods of high demand on coldest days of winter. Microgrid installations of natural-gas-fired generation systems at multiple locations provide opportunities to improve the quality and reliability of gas distribution that will benefit a wide range of customers throughout the Near Westside. While low pressures have been observed during high usage, one facility manager related that no loss of the NG network has been experienced in the past due to major storms.

The NG network should be considered an uninterruptable fuel supply for the community in the face of major storms because:

- (1) there are multiple network sources of NG,
- (2) the actual NG network load goes down in a major storm because the non-critical loads are not operating, and
- (3) there is no history of loss in past major storms

In addition, interruptible service is a financial construct, not a technical limitation. Home heating is considered the highest priority for continuity of supply in the face of challenges to the natural gas network. Since the microgrid's natural gas usage is for CHP (heating of critical facilities) and distributed within the home heating areas, it will be considered the highest priority for continuity of supply in the face of a major storm.

One of the elements in the feasibility assessment is the potential use of ground source heat pumps for heating and cooling. This would also reduce the natural gas load in the community, which could reduce further the risk of loss of natural gas supply during a major storm.

Also, the use of existing emergency diesel generators will be minimized by the microgrid's operation, therefore, the typical 3-day onsite fuel load for the emergency diesel generators will be extended to 1 week.

1.1.11 Demonstrate Resilience to Forces of Nature

The industry tends to focus on reliability and resiliency in terms of system average interruption duration index (SAIDI), customer average interruption duration index (CAIDI), and system average interruption frequency index (SAIFI). The IEEE 1366 reliability index of SAIDI (system average interruption duration index) is a transmission and distribution (T&D) network-level index that specifically precludes storm outages. The IEEE 1366 consensus standard considers outages due to storms to be outside the utility's responsibility to prevent. The range of utility distribution network SAIDI and CAIDI in the US is between 60 and 200 minutes (national average ~ 120) per customer per non-storm outage. The outage numbers with storms included is much higher.

Therefore, the SAIDI measure is not really consistent with the concept of community resiliency, since SAIDI does not measure resiliency to storms. The IEEE 1366 measures are network focused.

In contrast, the reliability measures used in the data center industry are much more centered on the end-user reliability. The data center industry's Uptime Institute provides much information about designing highly resilient customer (data center) systems. Uptime is defined as serving the mission, and downtime is defined as not serving the mission.

We believe that resiliency is a customer-facing objective and the metrics to demonstrate resiliency should be customer-facing as well.

Based on discussions with National Grid, the Project Team believes that the neighborhood is representative of National Grid's Upstate service territory, in which the 2012 Reliability Report lists metrics SAIFI = 0.9 and CAIDI = ~120 minutes/customer/year.³ As before, these metrics are not really resiliency indicators. National Grid storm reliability data is not available. However, using data from ConEd in the same 2012 Reliability Report, storm caused outages with an average duration three times as long. Additionally, weather-related storm outages are on the rise.⁴ Past storm data is not an indication of outages that are likely to occur in the future. The National Grid reported performance in terms of SAIFI, CAIDI do not include major storms which exceed a certain threshold of customers experiencing an outage in an operating region.

Task 2 will more fully evaluate neighborhood-specific quality and reliability issues for both electric and gas distribution. The microgrid design is customer-facing resiliency, thus looking to uptime of the customer / critical facilities and their ability to achieve their mission will be a goal of this assessment. The nodalized, or nested, microgrid design is a direct attempt to address facility-specific uptime in the face of major storms, i.e., resiliency.

The microgrid equipment will be designed to perform after being exposed to numerous environmental assaults including wind, rain, flooding, extreme heat and cold, and earthquake. The design criteria for disruptive phenomena are described below.

Wind / Tornado / Derecho

The designs for DER structures (base foundations, enclosures, and connections) for distributed generators, CHP, outdoor energy storage, solar PV panels (hail rated) and racking, and electrical and thermal distribution equipment will withstand Category F2 wind speeds. Installation of energy storage systems will be inside interior building electrical or mechanical rooms wherever possible.

Rain / Flooding / Hurricane

The design of the structures (base foundations, enclosures, and connections) for distributed generators, fuel cells, CHP, outdoor energy storage, solar PV panels (hail rated) and racking, and electrical and thermal distribution equipment will withstand Category 4 Hurricane (Staffer-Simpson scale, same maximum wind speed as the Category F2 tornado on the Fujita scale). In addition, the height of the base foundation for outdoor units is designed to assure the equipment is 1 to 1.5 feet above the 100-year flood plain level. Installation of energy storage systems will be inside interior building electrical or mechanical rooms wherever possible.

Earthquake

The design of the structures (base foundations, enclosures, and connections) for distributed generators, fuel cells, CHP, outdoor energy storage, solar PV panels (hail rated) and racking, and electrical distribution equipment will withstand seismic event magnitude 6.9 (Richter scale), or 100-year local seismic event, whichever is lesser. Due consideration is given to the design to overhead risk from buildings and other structures located above the microgrid equipment.

Heat

The design the structures (base foundations, enclosures, and connections) for distributed generators, fuel cells, CHP, outdoor energy storage, solar PV panels (hail rated) and racking, and electrical distribution equipment will withstand 125°F (50°C) continuous operating temperatures. Where

³ National Grid has indicated that the area sees 0.5 interruption per year - those are typically under 2 hours. The area was affected by 1 storm in the last 5 years

⁴ Executive Office of the President. (2013). *Economic Benefits of Increasing Electric Grid Resilience to Weather Outages*. http://energy.gov/sites/prod/files/2013/08/f2/Grid%20Resiliency%20Report_FINAL.pdf

equipment enclosure temperatures are expected to exceed these temperatures for more than 10 minutes, space cooling is added.

Cold / Ice

The design of the structures (base foundations, enclosures, and connections) for distributed generators, fuel cells, CHP, outdoor energy storage, solar PV panels (hail rated) and racking, and electrical distribution equipment will withstand 15°F (-24°C) continuous operating temperatures. Where equipment enclosure temperatures are expected to fall below these temperatures for more than 10 minutes, space heating is added. Enclosure design includes mitigation of ice formations that block airflow.

1.1.12 Provide Black Start

Our Project Team employs the Black Start Use Case from EPRI/ORNL:

Black start: The local microgrid controller will provide a workflow process for restarting the system. Each microgrid node will have a unique sequence of operations for predetermined use cases. One objective will be to provide this function both locally and remotely to meet the reliability requirements of the overall design.

The proposed microgrid solution has multiple black-start sources. The existing emergency generators at several locations have black-start capabilities, and automatically start on loss of the distribution grid.

In addition, each of the distributed energy storage systems within the microgrid is voltage source (normal mode) or current source (selectable). These units act as black-start capable units within 50 milliseconds of loss of voltage at the distribution grid.

In addition, the natural gas engine-based CHP units can be purchased as black-start capable.

Our scheme leads with the energy storage units in the case where a black-start would normally be required. As such, the energy storage units will serve as the first voltage source for all other equipment. For defense in depth, the emergency diesels and the CHP have the ability to serve as voltage sources for all equipment.

1.2. Preferable Microgrid Capabilities

1.2.1 Integrate and Demonstrate Operation of Advanced, Innovative Technologies in Design and Operation

Our Project Team intends to employ the microgrid EPRI/ORNL Use Cases for the microgrid feasibility study. These generic use cases provide the Team with a starting point for tailoring the use cases to the community's microgrid controls situation. The use cases are described below, plus another generic use case on Security was added because a community resiliency microgrid represents a high-value target requiring a secure system of operations.

- **Frequency control:** In normal operations, the microgrid may not have enough resources to affect frequency on the grid. It could participate in the ancillary services markets by increasing output to support the frequency in the local grid, but total impact would be small. Nevertheless, the system will monitor frequency along several thresholds – providing a discrete high-low range; the system will detect if frequency is out of range and respond by taking resources off-line, or dispatch other resources to manage frequency. Also, the system will analyze data to detect subtler trends that do not exceed thresholds, but provide evidence of a possible problem.

Work proceeds to build underlying components of GreenBus, model generation assets, SCADA, and metering systems and to design a dashboard interface to autonomous real-time systems.

- **Voltage control:** In both grid-connected and islanded modes, the voltage control application will be used to provide stability to the microgrid and connected circuits. Voltage control leverages line sensing and metering to provide control actions when necessary. The application will take into account traditional volt/VAr instruments such as tap changers and cap banks along with inverter-based resources, which should provide a greater degree of optimization.
- **Intentional islanding:** For each microgrid node, the islanding process will be semi-automatic so that a utility operator or local energy manager will be able to step through each step before opening the PCC. The utility operator will provide the appropriate permission for opening the PCC. The local microgrid controller for each microgrid node will be responsible for setting the voltage source and load following resource.
- **Unintentional islanding:** For each microgrid node, the islanding process will be automatic as described in section 1.1.d above.
- **Islanding to grid connected transition:** As with intentional islanding the utility operator will provide the appropriate permission to close in the PCC. The local microgrid controller will support the reconfiguration of each dispatchable resource.
- **Energy management:** This is the most complex EPRI/ORNL Use Case. Design incorporates a portfolio of resources. The EPRI/ORNL Use Case takes a traditional energy management approach, including economic dispatch, short-term dispatch, optimal power flow, and other processes typical in utility control room environments. The microgrid controller will have corresponding applications that manage at a set of controllable generation and load assets. Within that portfolio, the system will optimize the microgrid based on load forecast, ancillary services events, changes in configuration, outage of specific equipment, or any other kind of change to determine the optimal use of assets 48 hours ahead.
- **Microgrid protection:** The microgrid controller will ensure two primary conditions. The first is that each protection device is properly configured for the current state of the microgrid, either islanded or grid connected. The second condition is that after a transition the microgrid controller will switch setting or verify that the setting has changed appropriately. In either condition if the test is false then the controller will initiate a shutdown of each resource and give the appropriate alarm.
- **Ancillary services:** The primary point of this use case is to provide fleet control of the nested microgrid parts. Specifically, the utility operation will have the ability to request and or schedule balance up and balance down objectives for the fleet. The cloud-based controller will take the responsibility to parcel out the objectives for each microgrid part based on the available capacity.
- **Black start:** The local microgrid controller will provide a workflow process for restarting the system. Each microgrid part will have a unique sequence of operations for predetermined use cases. One objective will be to provide this function both locally and remotely to meet the reliability requirements of the overall design.
- **User interface and data management:** The solution provides local controllers in each microgrid part as well as a hosted controller that can operate each microgrid part separately or collectively. The primary actors are the utility operator, local energy managers, maintenance

personnel, and analyst. The user experience for each actor will be guided by a rich dashboard for primary function in the system around Operations, Stability, Ancillary Services, and Administration.

- **Security:** – The solution will demonstrate a trustful design and integration. This will include the following:
 - a. show how human and machine actors are authenticated and authorized,
 - b. show how data in motion is protected,
 - c. show how data at rest is managed, and
 - d. show how system monitoring is accomplished

Domain data will be used to provide simple event processing for anomaly detection and a threat model of the system will be in place to help analyze suspect operations.

From a customer perspective, an emergency generator serves 4 or 5 of these Use Cases, the utility grid serves 5 or 6 of these Use Cases, but the microgrid serves all 11 Use Cases.

The fundamental driver for the microgrid is to create a resilient energy supply for critical facilities, while at the same time creating better economics and reducing the emissions footprint. With active control, new distributed energy technologies, and the coordinated signals to drive decisions, solving the multi-objective function is doable.

Active Network Control System

One of the challenges of community microgrids is that the facilities and the microgrid resources are distributed. To maximize the economics, reliability and emissions reduction potential of the community microgrid, the microgrid controller architecture must have the capability to coordinate and control groups of resources as well as provide control for localized operations. Figure 1.9 presents the project concept for the community microgrid controller.

Figure 1.9 – Project Concept for Community Microgrid

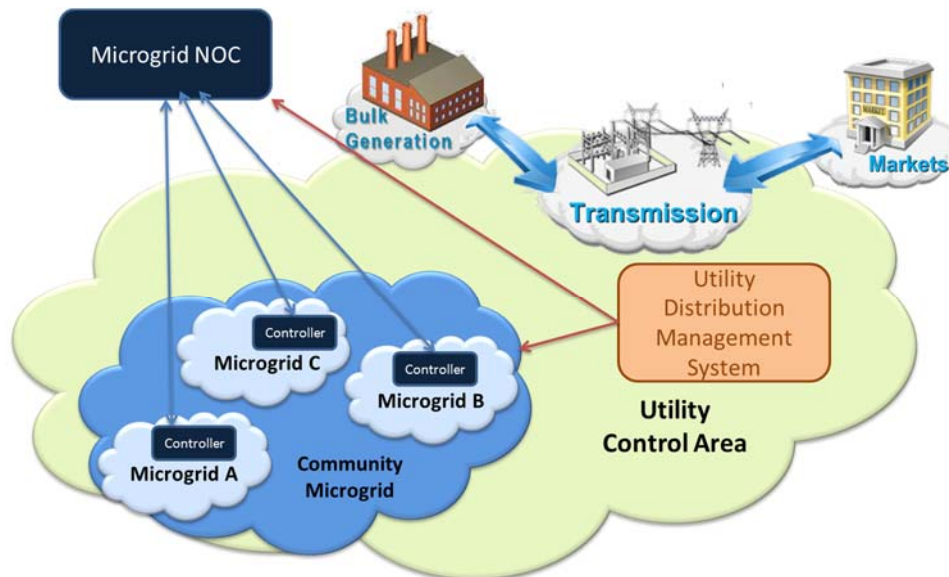

This approach provides for control of multiple microgrids in the community as well as coordination with the local utility. In the grid-connected mode, the primary operations will focus on maximizing economic benefits and minimizing emissions, which is similar across all the microgrids within the community. In

some cases, the aggregation of the microgrid resources can be leveraged to support utility firming request and/or RTO/ISO ancillary services such as demand response and frequency regulation. During a reliability event, the operation of each microgrid controller is focused on the load and generation assets within its control. The local controller will transition to island mode while maintaining proper voltage and frequency.

The anticipated microgrid controller will be based on GreenBus[®], as described above. The GreenBus Microgrid Solution is currently being evaluated by the US Department of Energy under a contract for microgrid control systems.

The GreenBus design enables low latency messaging and secure transport to communicate with clients on field devices, the microgrid data center and the utility distribution management system. The GreenBus suite of service interfaces allows application developers to focus on building their application, while GreenBus abstracts out the work of managing the field data:

- Provides data automation and control features typical in the utility industry;
- Provides a cross-platform suite of developer APIs that allow many subject matter experts to leverage the platform without becoming experts; and
- Supports integration of intelligent field devices and back-office systems through the use of an industry standard wire level protocol (AMQP), common enterprise integration patterns (EIP), and a suite of near-real time special purpose services (APIs).

GreenBus supports both a DNP3.0 level 2 compliant slave and master operation, Modbus and over 80 proprietary field protocols for data acquisition and control. This package provides the basics of a traditional SCADA (supervisory control and data acquisition) system built on a service oriented architecture. This includes control features like select before operate (SBO), direct operate (DO), and set points, as well as support of measurement streams for analogs, status, and counters over a common bus architecture regardless of the device type. Other functions include *Not in Service*, *Manually Replace*, *Control Blocks*, *Limits*, definable alarms and events, and system and device timestamps.

GreenBus will be leveraged as a platform to demonstrate the Open Field Message Bus⁵. The demonstration of a machine-to-machine control architecture for microgrid operation is shown in Figure 1.10 below.

⁵ Open Field Message Bus is copyrighted by the Smart Grid Interoperability Panel

Figure 1.10 – Control Architecture

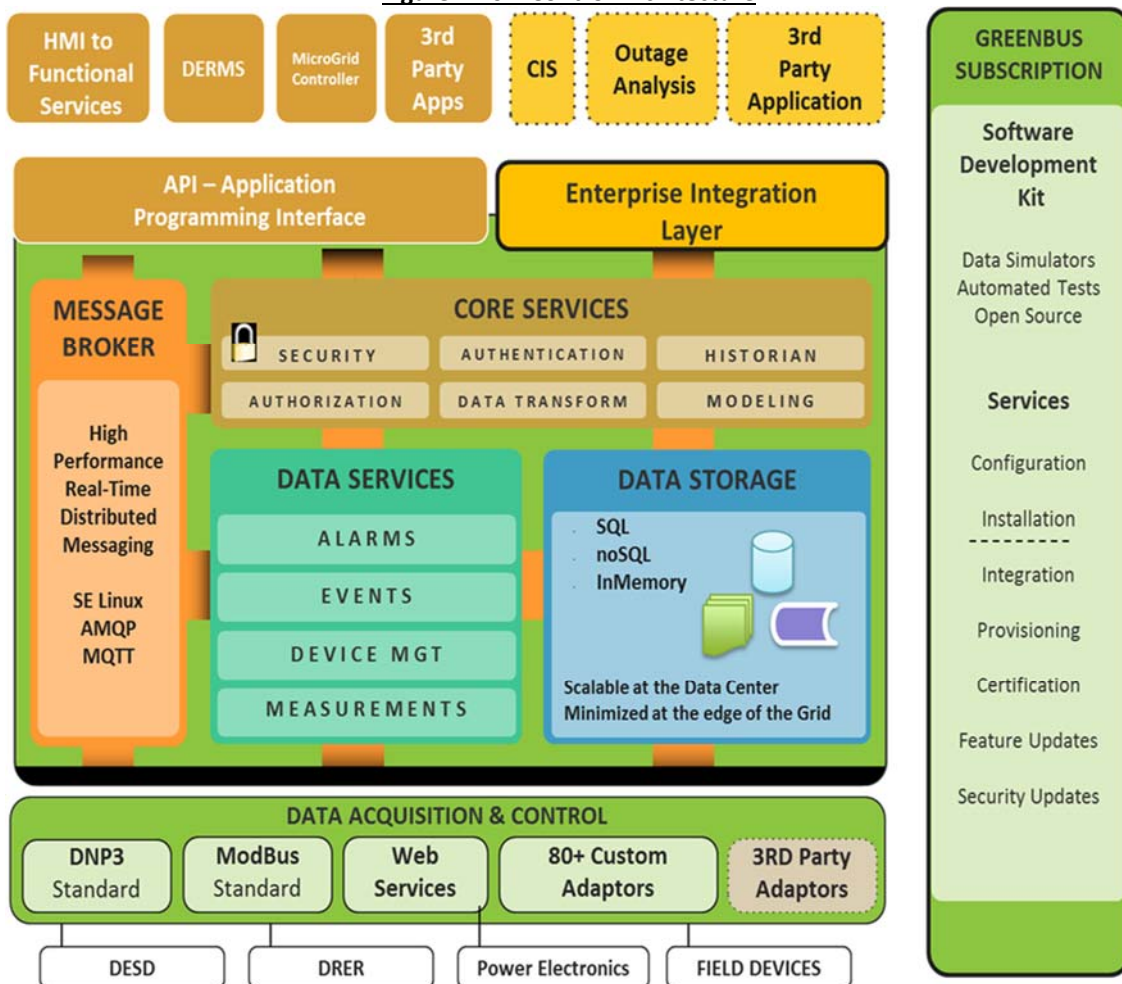

The GreenBus is designed to leverage applicable security controls as defined by NIST and specifically the NISTIR 7628 of operations technology (OT) and information technology (IT) systems in the seven-domain NIST interoperability model. The trust model has many dimensions where the first tangible one is that nothing is trusted on the wire unless authenticated. Denial of Services (DOS) attacks are considered high and the system employs various techniques and deployment architectures to mitigate this type of malicious cyber-attack. The elevation of privilege threats is considered high in all subsystems.

The GreenBus system uses a concept called “agents” to represent processes and humans in the system. All agents must be authenticated to the system and all permissions are based on Access Control Lists (ACL) with a *deny-all* rule as default. ACLs are granularly applied to objects for each agent in the system. The ACL works by specifying the resource (service), the “create, read, update, and delete” (CRUD) operation required, and an optional selector to narrow it down by entity type, entity parent, or to the agent’s self (i.e., update your own password).

GreenBus is designed to run across multiple electronic security perimeters with an encrypted pipe for all forms of traffic. This is typically on top of AMQP. This simplifies network configuration and allows for better auditing of the overall system connection health.

GreenBus is certified on RHEL 6, which inherits Security Enhanced Linux (developed by the US National Security Agency and Red Hat) for setting security policies. GreenBus also supports multiple modeling types such as equipment models, communication models, and generic configuration files to support application configurations. Finally, every connection to the system is authenticated and granular level authorizations can be applied to suit the system requirements

The GreenBus Microgrid Master Controller (MMC) Application Suite is layered on top of the GreenBus Platform. The GreenBus MMC is design to address the use cases described above. The architecture of this solution allows the microgrid controller running locally in each microgrid to be autonomous from the cloud based system for extended periods of time. The Microgrid NOC runs the same GreenBus software as the local microgrid controller and support coordination features between each microgrid as well as a single panel of glass to govern the entire system.

Energy Efficiency Options

For energy efficiency, the team’s philosophy is “Lead with Energy Efficiency.” Before considering other aspects of microgrid design, it makes sense to maximize energy efficiency gains. Distributed energy resources can then be matched to a new, lower load profile to avoid over-sizing capacity and over-investing in the associated equipment.

The microgrid Team will include an analysis of energy performance improvement opportunities in the microgrid design. Our Team intends to follow a six-step process covering data collection, analysis, on-site evaluations, technology retrofit selection, installation, and operation.

Data Collection – The Project Team conducted on-site evaluations of the facilities to be included in the Syracuse microgrid. These visits include a review of recent, planned, and/or possible future energy efficiency and DR measures for the specific facility.

In addition, students are conducting several site visits with a specific focus on energy efficiency. They are interviewing facility managers and identifying multiple opportunities for energy improvements.

Data Analysis – The information collected will be used to conduct energy performance benchmarking for the portfolio of facilities – normalized by square footage, water, operating hours and, if applicable, facility type. This analysis will be used to identify any trends in energy use intensity across, time, geography, or technologies employed.

On-Site Evaluations – Findings of the data analysis will be used to determine high and low performers across the portfolio. The Team will identify the facilities with the highest and with the lowest normalized energy intensity to perform on-site energy audits. The findings of these audits will be used to develop general best practices that the team can use as a framework for incorporating energy efficiency into the microgrid project.

Technology Retrofit Recommendations – The Team will use information from the three previous steps to identify energy efficiency retrofits for the critical facilities. The Team will focus on identifying measures that can be deployed across the entire portfolio and that have a payback of less than five years. Areas of focus include (but are not necessarily limited to): lighting, HVAC, controls, and refrigeration efficiency.

Installation – The Team will incorporate the selected energy efficiency measures into a microgrid design. The Team will evaluate the procurement and installation of the measures as coordinated with the microgrid installation. Since there is a potential that some energy efficiency measure will take place in non-critical facilities, the team will evaluate installation activities with commercial businesses in mind to ensure minimal impact to operations and customers.

Operation – The microgrid team will evaluate the “installed” energy efficiency measures to ensure proper operation in concert with the microgrid. As part of the microgrid control system, energy usage will be continuously monitored. This will provide a tool to validate the energy savings realized by the portfolio of energy efficiency measures installed at each facility. Facilities that are not meeting the energy savings goals will be re-evaluated to identify and correct the short fall in energy savings.

Installation, Operations, Maintenance, and Communications for the System to be Interconnected

The envisioned business structure for the microgrid is to fund the project through 3rd party investors that are represented as the owners of the microgrid through a Special Purpose Entity (SPE). The SPE will engage the design and engineering team to finalize the construction drawings and utility interconnection agreements. The SPE will execute the construction through a contract with an Engineer, Procure, and Construct (EPC) firm. The EPC will be responsible for any remaining engineering, procurement of major equipment, construction of the project, and system integration for the controls and communications. This process is presented in the Figure 1.11 below.

Figure 1.11 – Business Structure Process

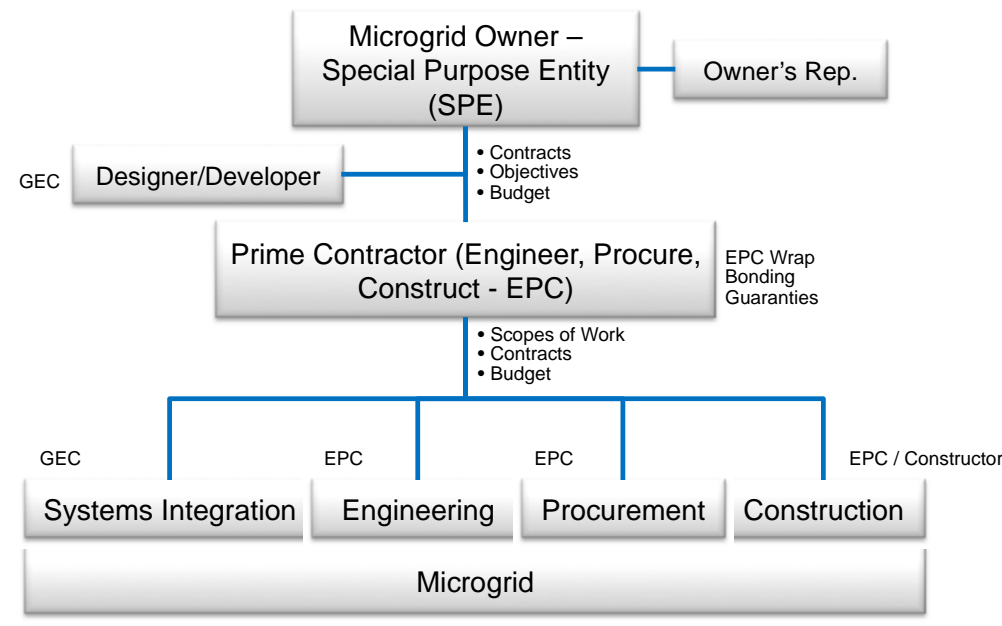

To ensure proper operation of the individual microgrid resources, the EPC will conduct site acceptance tests that validate the operation and performance of the new equipment. Once the system construction and integration are complete, the SPE will engage a third-party commissioning agent that will test the microgrid as a system to ensure that the controls, communication and sequence of operation function to meet the requirements as defined in the use cases and the final design.

After the fully commissioned system is accepted and transferred to the SPE, the SPE will own and operate the microgrid for a period of 15 to 25 years. The operation will leverage the autonomous functionality of the microgrid controller and minimize the need for on site operators. The controller will operate the microgrid in a manner to maximize economic benefits, minimize emissions, and maximize reliability of service in the event of a fault on the grid. In addition, the microgrid controller will monitor the performance, operation and alarms of the distributed resources. In the event of an alarm, the SPE will be notified through the NOC and dispatch a service technician that will be engaged through a service contract. The microgrid controller will also track the hours of operation of each microgrid resource and

will employ a predictive maintenance strategy to schedule maintenance before a failure and at a time period that will be the least impactful to the overall operation of the microgrid.

Coordinate with REV Work – Platform of Innovative Services

A key objective of the proposed microgrid involves modernizing local grid infrastructure and establishing a platform for development and operation of innovative and competitive energy assets and resources. This is consistent with the objectives of New York’s Reforming the Energy Vision (REV). Achieving this objective involves two primary processes:

- 1) Enabling safe and reliable dispatch of distributed resources within the community microgrid service area through:
 - a. Physical reconfiguration and upgrades of local distribution systems (including installing buried cable to connect some nodes)
 - b. Deployment of distributed data acquisition and control systems
- 2) Enabling economic dispatch of microgrid energy and capacity resources (including customer loads), primarily through:
 - a. Deployment of resource management and information management applications (microgrid controls)
 - b. Establishment of counterparty contracting and clearing mechanisms supporting deployment and operation of distributed energy assets.

A successful community microgrid will establish an engineering and economic platform that facilitates efficient ongoing development and investments in local energy assets, and provides incentives for operation of assets to achieve optimal outcomes consistent with microgrid objectives – *e.g.*, improved local resilience, energy self-reliance, environmental performance, and financial economics. Specifically, the proposed microgrid would establish a physical platform for various entities – including customers, third parties, and utility holding companies – to install, integrate, and operate distributed generation, ESS, and demand-side management systems as well as an economic platform for dispatching resources and managing economic transactions among counterparties within the microgrid service area.

Comprehensive Benefit Cost Analysis

As an input to the preliminary technical design, the Project Team will employ an energy and financial model in Tasks 2 and 3 to assist in the design of the actual microgrid for the community. Team members have used this approach in the design of more than 40 microgrids. It is based on detailed energy balancing, detailed total cost of ownership modeling, and the interaction of the two.

This model, presented in Figure 1.12 below, has proven valuable in properly sizing and siting microgrid resources and load modulation programs to support a microgrid design. The modeling tool helps ensure that the design meets the technical objectives of the project as well as the financial requirements related the price of energy generated by the microgrid and the return on investment required by the SPE investors.

Figure 1.12 – Energy and Financial Model

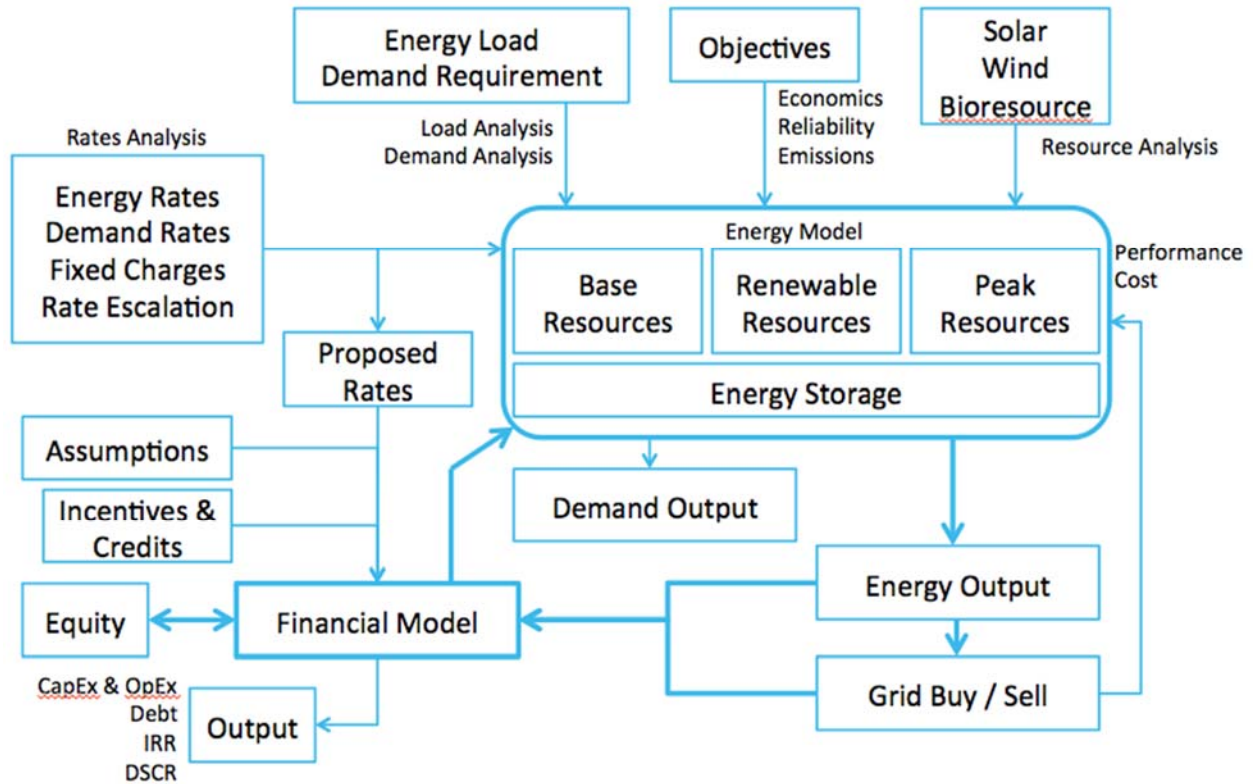

While it is understood that NYSERDA has developed its own cost benefit model and has contracted with a vendor to support our team in providing information for that model, we will take advantage of our existing model to “screen” options in order to identify the most promising design elements.

Leverage Maximum Private Capital

The Project Team has explored multiple ownership options to determine the most attractive ownership structure for the microgrid. The team believes that the most attractive structure will be a public-private community development entity with shared ownership between non-profit agencies and private companies.

As mentioned above, the vehicle for structuring the public-private development will be an SPE geared to the specific need and partners. Figure 1.13 shows the typical structure and relationship to energy end users, or off-takers.

Figure 1.13 – Special Purpose Entity (SPE)

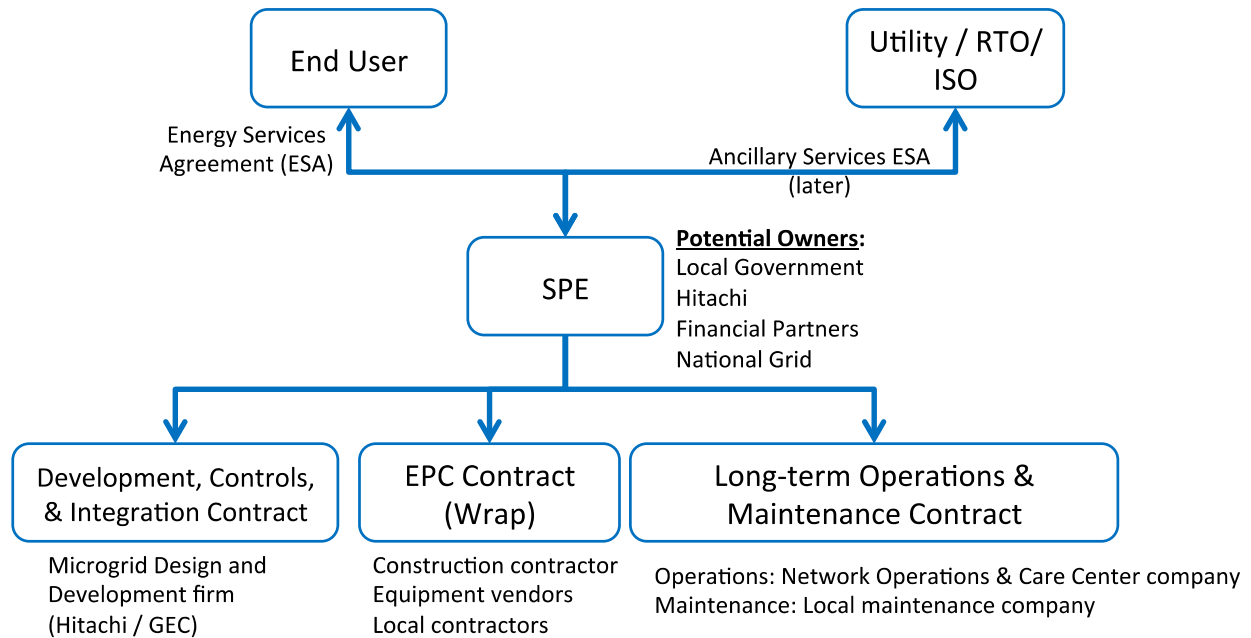

There can be more than one SPE serving and owning the community resiliency microgrid. Careful planning, legal review, and negotiations will be required for various scenarios. For example:

- A. Distributed energy resources behind the meter on public/government facilities – the SPE may be co-owned by the public/government authority, a special non-profit funding agency, and/or third-party investors
- B. Distributed energy resources behind the meter on private facilities – the SPE may be co-owned by third-party investors, local economic development agency, community group, and/or utility (likely a non-regulated business unit)
- C. Distributed energy resources behind the meter on private facilities – the SPE could be owned by third-party investors alone
- D. Distributed energy resources above the meter – the SPE may be co-owned by the public/government authority, a special non-profit funding agency, the utility, and/or third-party investors
- E. Distributed energy resources above the meter – the utility could be the sole owner

Leveraging maximum private capital could take place in each of the five options A through E.

In option A, the special non-profit funding agency is an IRS tax-exempt entity that uses private capital for passive taxation offsets, and the third-party investors are private capital firms.

In option B, the third-party investors are private capital firms and the utility will utilize private capital for its ownership share.

In option C, the third-party investors are private capital firms.

In option D, the special non-profit funding agency is a special IRS tax-exempt entity that uses private capital for passive taxation offsets, the utility will utilize private capital for its ownership share, and the third-party investors are private capital firms.

In option E, the utility will utilize private capital.

It is expected that the utility will continue to own and operate electric distribution lines.

Clean Power Resources

As discussed in the section on the microgrid portfolio of resources and the goal of reduced emissions, clean and renewable resources are key elements of our design approach. The primary types of clean energy resources that will be considered for this microgrid design, at this stage of the project, are CHP, PV, wind, and biogas.

CHP will be sized to operate economically at design output for at least 8,000 hours per year. This means that for a majority of the day the electrical load and CHP generation are closely coordinated. The thermal load, including thermal energy storage and existing boiler operations, will be considered to address the ramping requirements of the thermal load.

The use of PV as a generation resource within the microgrid serves as a resource that has a similar generation profile to the electric load of the microgrid. Even though PV generates electricity only during the day and can be intermittent on cloudy days, it is a resource that can be complemented by the other microgrid resources. PV has the benefit of having no fuel cost and very low maintenance cost which helps the economics of the overall microgrid project. In the Team's experience designing microgrids, the technical and economic solution will likely have content of PV which is approximately 20% of the generation content in terms of annual energy production.

Wind as a generation source is considered when there is a sufficient wind resource within the microgrid area. Review of the wind resource in the Near Westside area indicates that wind generation will not be viable in this microgrid design.

Biogas can be considered in areas where there is agriculture, cattle farms, chicken farms, wood processing, or wastewater treatment facilities. In these instances, the evaluation includes the addition or use of an anaerobic digester that can produce sufficient methane to operate a generator or fuel cell. To properly evaluate the opportunity, we need to characterize the digester input sources and capacity and then estimate the rate of methane production and its heating value. In some cases, digester gas can be generated outside the microgrid control area, cleaned to specific standards, and injected into the local natural gas distribution system. Then, an arrangement can be made with the natural gas utility to extract the quantity of gas at the microgrid and count that gas as renewable. Potential sources of biomass that could be available for use in a microgrid in Syracuse's Near Westside neighborhood were explored in more detail in Task 2.

Demonstrate Tangible Community Benefits

The Near Westside Community is home to relatively large populations of low income and fixed income residents, making a sheltering-in-place response to extended grid outages and major storms and their aftermath a benefit to the community. For example, three high-rise apartment buildings in the James Geddes Housing Development are home to 269 vulnerable elderly and/or disabled residents, which make these facilities a high priority for providing a shelter-in-place emergency response.

In addition, 53% of the approximately 7,000 residents in the Near Westside live in households that have incomes below the poverty level, which typically limits options for relocation during extended power outages. Ratepayers are expected to benefit from economic development created by additional customers who are attracted to the project area due to availability of resilient clean-energy infrastructure.

The Near Westside Initiative's efforts in this neighborhood are focused on addressing the revitalization of this post-industrial area. Part of this effort is to create an environment for economic development through new businesses being attracted to the neighborhood. Resilient energy supply provided by a

microgrid is intended to be a strategic asset for attracting new businesses to the neighborhood. Not only would this potentially create new jobs, it would certainly protect existing businesses and jobs by providing solid business continuity. The Project Team will work closely with the Near Westside Initiative to provide tangible benefits to the community.

1.2.2 Incorporate Innovation that Strengthens the Surrounding Grid and Increases Actionable Information Available to Customers

Facilities in the Near Westside project area are served primarily from 5-kV-class feeders emanating from National Grid's Fayette Street substation on West Fayette Street. The substation is served by 34.5 kV sub transmission circuits. According to National Grid, there are no projected normal overloads in this area in the five-year planning horizon. However, the facilities are aging and it is National Grid's general practice to retire substations of this type when assets reach the end of their useful lives and replace them with equipment sourced from high transmission voltages.

The approach typically used by National Grid is to replace aging 5 kV facilities with existing or new distribution feeders emanating directly from alternative 115kV-13.2 kV transmission sources. From a utility planning perspective, the envisioned microgrid has the potential to extend the life of the Fayette Street substation by reducing the load on the substation transformers and associated feeders.

This may provide National Grid an option to defer the capital for some number of years to replace the substation. In addition, the envisioned microgrid has the potential to improve service reliability of this neighborhood, potentially meeting regulatory requirements for service reliability improvements for years to come without additional capital expenditures.

With strategically located distributed energy resources in the Near Westside Community, new options for the neighborhood distribution network for system efficiency and reliability are made available by enabling the microgrid to support distribution level ancillary services in the neighborhood.

With the microgrid comes a data-rich environment that can be made available to every business and resident. This data can be formulated in ways to provide business and residential consumers in the Near Westside neighborhood with reliability, economic, and emissions metrics that are important to them in near real-time, both from a community perspective and individual perspective.

Task 2. Preliminary Technical Design and Configuration

2.1. Proposed Microgrid Infrastructure and Operations

2.1.1 Microgrid Layout

As described in Task 1, the preliminary design for the envisioned microgrid in Syracuse’s Near Westside neighborhood uses an approach that has been developed by team members to improve resiliency in other communities in which targeted critical facilities are not contiguous. The preliminary design presented in Task 2 differs from the assessment made in Task 1 in that the project team has added a significant amount of customers to the neighborhood community loads. The loads for these customers are estimated based on existing data.

A schematic of the preliminary design showing all microgrid nodes is presented in Appendix A. All nodes are provided electrical service via distribution facilities from either National Grid’s Fayette Street substation or Ash Street substation. Existing resources that are planned to be incorporated into the microgrid are four backup generators and three solar PV arrays owned by customers in the community.

A one-line diagram of the envisioned microgrid is presented in Appendix B. The diagram includes the substations, major electrical equipment, and the rated capacity for each microgrid distributed energy resource. The points of common coupling (PCC) are shown with associated monitoring (M), control (C), and protection (P) devices. Figure 2.1 includes a brief explanation of the elements included in the one-line diagram. Table 2.1 provides a listing of facilities served by each node.

Figure 2.1 – Key Components in the One-Line Diagram

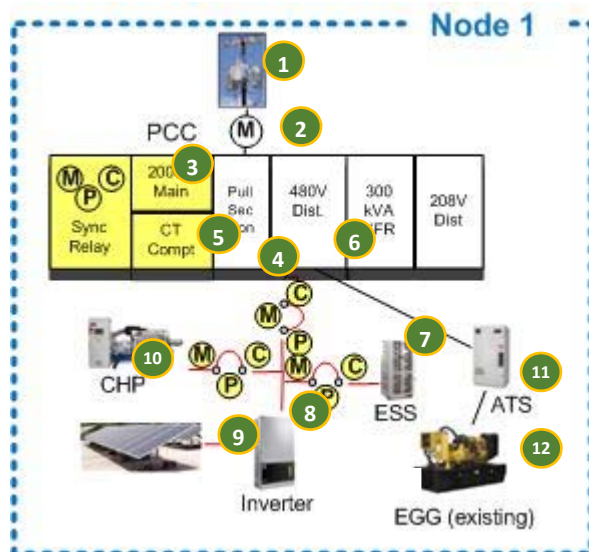

1. Utility distribution infrastructure
2. Utility meter
3. Synchronizing relay controls / main breaker with monitoring (M), protection (P) relays and controls (C)
4. Main disconnect (pull section)
5. Instrument current transformer compartment
6. Main distribution panel (480V 3-phase shown in example. The panel at each facility will match the voltage present at the existing service. Where required, installation will include step-down transformer and 208V 1-phase distribution panel.)
7. Energy storage system (ESS) with M, C, P
8. New 480 Volt, 3-phase infrastructure (red)
9. Solar PV array and associated inverter
10. Combined Heat & Power (CHP)
11. Automatic Transfer Switch (ATS)
12. Emergency gas generator (EGG) or emergency diesel generator (EDG)
13. Neighborhood Community Load (NCL)

Table 2.1 – Overview of Proposed Syracuse Near Westside Microgrid Nodes

Microgrid Node #	Name	Facilities	Functions
1	Fire Station #6	<ul style="list-style-type: none"> • Fire Station 	<ul style="list-style-type: none"> • Public Safety
2	Northeast SALT District Community Partners	<ul style="list-style-type: none"> • WCNY • Delavan Center • King + King Architects • Steri Pharma • Hillside Children’s Center • Lincoln Supply • P.E.A.C.E. Westside Center • CNY Services 	<ul style="list-style-type: none"> • Public television/ radio • Economic Development • Community Services
3	Southeast SALT District Community Partners	<ul style="list-style-type: none"> • Syracuse Housing Authority: James Geddes Housing Development • Gilford & West Pharmacy • Nojaim’s Market • Huntington Family Center • St. Lucy’s Church • St. Joseph’s Hospital Primary Health Care Center • Seymour Academy 	<ul style="list-style-type: none"> • Housing • Medical Services / Medicine • Food • Community Services • Emergency Shelter • Education
4	Blodgett School	<ul style="list-style-type: none"> • Westside Academy at Blodgett 	<ul style="list-style-type: none"> • Education • Emergency Shelter
5	Rockwest Center	<ul style="list-style-type: none"> • Police Dept. Neighborhood Station • Various Commercial 	<ul style="list-style-type: none"> • Public Safety • Economic Development • Community Services
6	Fowler High School	<ul style="list-style-type: none"> • Fowler High School 	<ul style="list-style-type: none"> • Education • Emergency Shelter
NER	“Neighborhood Energy Resource (NER)”	Resources installed at the Fayette St. substation and/or distributed along three feeders that serve customers throughout the Near Westside community.	<ul style="list-style-type: none"> • Electric Service to “Neighborhood Community Loads (NCLs)”

2.1.2 Normal and Emergency Operations

The selection and sizing of Distributed Energy Resources (DERs) is based on a *Microgrid Resource Portfolio Approach* that members of our team have developed over several years based on lessons learned in the design of more than 40 microgrids to date.^{6,7} The approach focuses on energy requirements and a close match to the electric load profile of all covered facilities. The peak demand for critical facilities in the community occurs only a few hours per year. This means all critical facility services can be provided by “always-on” microgrid resources for the majority of hours in a year without overbuilding. The goal of this approach is to enable microgrid resources to serve the microgrid loads more efficiently, more cost effectively, and with lower emissions per unit of energy consumed.

Under the Microgrid Resource Portfolio Approach (Figure 1.5), base-load Combined Heat and Power (CHP) systems are designed to run at design output for at least 8,000 hours per year. To meet the load that varies above the base load, resources such as photovoltaic (PV) and energy storage are integrated into the system. Energy storage systems are specified based on their capability to change output rapidly and address the ramp-rate issue to support load following, and buffering the differences between CHP, electrical load, and PV throughout the day.

From a long-term operations and maintenance standpoint, the Portfolio Approach enables the microgrid to operate energy resources in ways that minimize maintenance costs and fuel costs, which helps to lower the total cost of ownership. The design also incorporates active microgrid controls that enable optimal operation of energy storage, PV, and building management systems to manage load and reduce the afternoon peak load when needed. Experience has shown that costs to customers are minimized when microgrid resources are designed to meet 80% to 86% of annual loads.

The load duration curve (Figure 1.6) illustrates another element of the resource selection and sizing strategy for the Near Westside microgrid. When operating in a grid-connected mode, the microgrid uses the grid as a resource to meet peak demand periods. When operating in island mode, the microgrid supply and demand will be balanced locally through the dispatch of microgrid generation resources, load management, and to a minimum extent, the use of existing backup generation. This methodology allows the designers to evaluate the appropriate balance of grid service, generation resources, and load management capabilities, and provide both a technical and economic solution.

One of the most important attributes of the envisioned Near Westside community microgrid is to provide resilience by incorporating the ability to operate when the utility grid is not available. The methods of transitioning into an island mode are characterized as either a (1) planned transition or (2) unplanned transition.

- **Planned Transition:** In a planned transition, outside information is used to ramp up resources so there is zero grid import to the microgrid. A seamless transition occurs into island operations at the appropriate time. Outside information includes weather forecasts, grid frequency deviations, local voltage sags, or other information provided by the utility.
- **In an unplanned transition,** an unanticipated outage takes place such as the loss of a transformer, or a car hitting a distribution power pole requiring the microgrid to establish internally balanced operation itself through a black-start sequence of operation.

⁶ Pullins, Steve, “Microgrids: Aligning economics and resiliency,” presented at National Town Meeting on Demand Response and Smart Grid, May 2014; <http://www.demandresponsetownmeeting.com/wp-content/uploads/2012/03/Pullins-Steve-3-SG.pdf>

⁷ Pullins, Steve, “Microgrids: Lessons from the field,” presented at 2nd National Microgrids Conference, Chicago, IL, September 2014.

The resources included in the Near Westside microgrid are sized and operated to support island operation at about 80-86% of typical peak daytime customer load, for a minimum period of seven days, with multi-week operation likely. A one week outage design criteria was selected and modeled during the design tasks. This duration was selected to address a major regional outage and to provide meaningful benefits to the community. During island mode operation, the microgrid control system will maintain system stability and ensure a balance of generation and load. The controller will forecast critical load and PV generation, and then dispatch resources to match the load. The resources available to be controlled during island operations will include CHP, fossil fuel generators, PV systems, energy storage, and building load. We also expect that the utility will be able to provide an estimated time to restoration. This estimate will be used to help determine the remaining duration of island operation required, and will influence the dispatch of microgrid resources some of which may be energy limited (e.g. PV during the day).

The design strategy for the Near Westside microgrid is to supply the critical loads at levels that enable critical services to be provided at levels that are sufficient keep the community functioning throughout the entire outage event duration. This provides sufficient functionality for police, fire, and emergency services, while also providing some level of heat and power to other facilities and residents.

2.2. Load Characterization

2.2.1 Modeling Methodology

The microgrid was modeled using HOMER Pro (Hybrid Optimization Model for Multiple Energy Resources). HOMER Pro is a microgrid software tool originally developed at the National Renewable Energy Laboratory (NREL), and enhanced and distributed by HOMER Energy. HOMER nests three integrated tools in one software product, allowing microgrid design and economics to be evaluated concurrently. The key features of HOMER Pro are:

- **Simulation:** HOMER simulates the operation of a hybrid microgrid for an entire year, in time steps from one minute to one hour.
- **Optimization:** HOMER examines all possible combinations of system types in a single run, and then sorts the systems according to the optimization variable of choice. (For the Near Westside, economics is used as the optimization basis.)
- **Sensitivity Analysis:** HOMER allows the user to run models using hypothetical scenarios. The user cannot control all aspects of a system, and cannot know the importance of a particular variable or option without running hundreds or thousands of simulations and comparing the results. HOMER makes it easy to compare thousands of possibilities in a single run.

The project team used licensed HOMER Pro microgrid modeling software to generate electrical and thermal load profiles for envisioned Near Westside community microgrid design. More details can be found in Appendix C.

2.2.2 Load Description

The microgrid design team modeled and optimized each of the six nodes and the Neighborhood Energy Resource (NER) separately. Table 2.2 presents an overview of the energy operations of the microgrid for annual and monthly average values. The microgrid will have a maximum demand of 13,127 kW and an average demand of 6,375 kW. The microgrid will deliver approximately 55,800,000 kWh per year. The thermal loads in the microgrid will be approximately 92,300,000 kBTU per year, of which approximately 25,500,000 kBTU will be recovered from the CHP systems and reused to support on-site thermal loads.

Table 2.2 –Microgrid Energy Overview: Grid Connected Operation

Node	Electric Demand		Electric Consumption		Thermal Load		Thermal Recovery	
	Max (kW)	Avg (kW)	kWh/year	kWh/month	kBTU/year	kBTU/month	kBTU/year	kBTU/month
1	47	12	106,698	8,892	895,053	74,588	229,996	19,166
2	810	307	2,686,160	223,847	10,406,930	867,244	481,102	40,092
3	1,191	401	3,508,521	292,377	45,042,297	3,753,525	12,356,360	1,029,697
4	190	51	443,277	36,940	15,591,351	1,299,279	803,363	66,947
5	304	51	446,862	37,239	2,204,475	183,706	505,774	42,148
6	722	357	3,130,670	260,889	18,149,157	1,512,430	11,155,693	929,641
NER	9,863	5,197	45,527,143	3,793,929	0	0	0	0
Total	13,127	6,375	55,849,332	4,654,111	92,289,262	7,690,772	25,532,287	2,127,691

Table 2.3 –Monthly Grid Connected Operation by Node

Month	Node 1	Node 2	Node 3	Node 4	Node 5	Node 6	NER	Total
	(kWh)							
Jan	7,562	226,136	312,483	36,833	42,768	218,831	4,075,662	4,920,275
Feb	6,204	205,095	255,355	32,183	39,229	185,024	3,650,754	4,373,843
Mar	7,933	228,697	302,764	40,143	44,193	223,163	3,962,055	4,808,948
Apr	6,811	195,397	293,987	34,424	32,331	220,497	3,599,280	4,382,728
May	7,737	225,523	273,498	38,154	33,639	311,212	3,524,675	4,414,439
Jun	10,768	256,742	301,721	40,093	37,426	341,362	3,862,947	4,851,060
Jul	12,975	245,186	314,554	31,063	34,959	339,782	4,176,865	5,155,384
Aug	12,425	255,793	323,728	38,151	36,837	274,571	3,965,141	4,906,646
Sep	12,099	214,620	294,633	40,723	32,205	284,826	3,695,059	4,574,165
Oct	7,490	205,273	287,945	38,062	36,789	266,544	3,559,901	4,402,005
Nov	6,909	214,554	275,403	37,806	37,807	238,038	3,442,312	4,252,830
Dec	7,784	213,142	272,449	35,641	38,679	226,820	4,012,493	4,807,009
Total	106,698	2,686,160	3,508,521	443,277	446,862	3,130,670	45,527,143	55,849,332

The monthly energy delivery by microgrid node are presented in Table 2.3 and presented graphically in Figure 2.2.

Figure 2.2 – Monthly Grid Connected Operation by Node

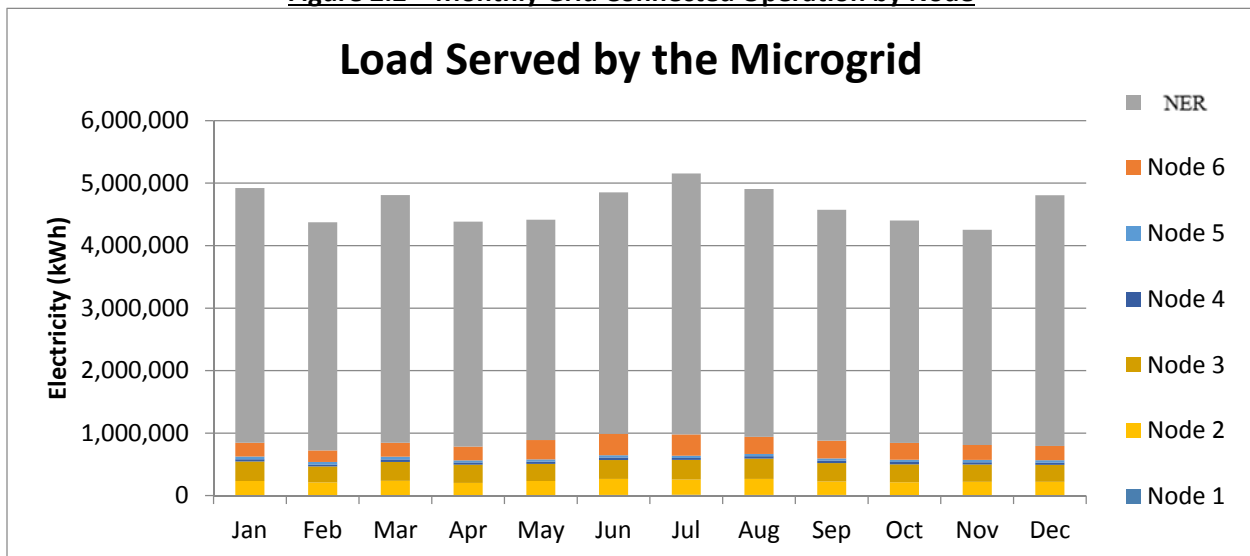

Each node was modeled for operation during an extended outage of one week to evaluate and optimize microgrid resources operating in island mode. Two outage events were modeled which represent an outage during the winter and an outage during the summer. Power and Energy flows during the outages are presented as weekly averages in Table 2.4.

Table 2.4 –Microgrid Energy Overview: Island Mode Operation

Node	Season	Electric Demand		Electric Consumption	Thermal Load	Thermal Recovery
		Max	Avg	kWh/week	kBTU/week	kBTU/week
1	Winter	24	10	1,682	45,140	7,161
	Summer	20	11	1,835	415.625	415.625
2	Winter	491	197	33,030	547,852	11,333
	Summer	471	219	36,831	4,502	3,880
3	Winter	729	391	65,721	2,098,963	296,905
	Summer	678	343	57,544	103,018	103,018
4	Winter	123	38	6,404	767,241	17,356
	Summer	103	39	6,635	9,473	8,958
5	Winter	173	41	6,858	136,497	17,749
	Summer	158	43	7,218	236.25	236.25
6	Winter	413	295	49,524	647,934	248,625
	Summer	427	356	59,857	196,954	194,341
NER	Winter	4,819	4,497	755,468	0	0
	Summer	4,819	4,372	734,444	0	0
Total	Winter	6,772	5,468	918,686	4,243,627	599,128
	Summer	6,676	5,383	904,363	314,598	310,849

2.2.3 Sizing Loads and System Redundancy

The traditional reserve margins and redundancy that the utility industry uses to describe elements of reliability do not necessarily apply to microgrids. For example, planners of the utility grid employ generation reserve margins at 15% to 23% and N-1 contingency criteria where the grid can accommodate the loss of the largest single unit in a utility control area.⁸ A long history of grid performance data demonstrates that “redundancy” (reserve margin and N-1 contingency criteria) has little to do with reliability directly at the customer site because the vast majority of customer experienced outages are due to distribution system failures which are not modeled in the bulk power system reliability studies.

In contrast to this, experience with operating microgrids within the US and overseas that this microgrid approach yields a significant increase in uptime for the customer than the utility by itself, which employs reserve margins and redundancy measures for the grid.

Following the team’s Microgrid Research Portfolio Approach, the Near Westside microgrid nodes are designed for 80% to 86% of the node customer energy supply from on-site resources, with the remainder of the energy coming from the grid when the grid is operating. The microgrid treats the utility grid as an additional resource, and includes reliability history of the grid into reliability optimization.

The reliability of the Near Westside microgrid will be ensured with the following measures:

- The use of multiple, distributed, smaller unit sizes to help minimize generation loss and ensure that the microgrid can gracefully accommodate the failure.
- The use of distributed energy storage systems that can accommodate short periods of high loading if the resource loss reason is known and quickly recoverable (15 minutes).
- Increasing the energy dispatch from the grid (in grid-connected mode - 99% of the time), to accommodate the loss of a resource until recovered.
- The use of a combination of ESS and load modulation (up to 20% without curtailment) in island mode to accommodate the loss of a resource for a few hours.
- Much greater local use of underground cabling and indoor infrastructure than is seen in the traditional utility grid.

These techniques are employed in the Near Westside microgrid design so that equipment loss is mitigated or accommodated in the specific microgrid nodes for this community, under both grid-connected and islanded modes of operation. Table 2.5 summarizes the microgrid resources in each node in terms of number of devices and the total installed capacity by technology. (These figures include estimates of opportunities to reduce loads via deployment of Energy-Efficiency Measures.)

⁸ For an understanding of the current reserve margin basis in New York of 17.4% see the New York State Reliability Council 2016-2017 Installed Reserve Margin Study Report at:

<http://www.nysrc.org/pdf/Reports/2016%20IRM%20Tech%20Study%20Report%20Final%2012-15-15.pdf>

Table 2.5 – Microgrid Node Resource Specifications Comparison (including Energy-Efficiency Measures)

Node	Operation Scenario	Grid	PV		Battery Energy Storage		Natural Gas Engine or CHP		Backup Generators	
		Peak kW	#	kW	#	kW / kWh	#	kW	#	kW
1	Business as Usual	47	-	-	-	-	-	-	-	-
	Microgrid	25	1	5	1	5/10	2	10	-	-
2	Business as Usual	810	3	138	-	-	-	-	1	650
	Microgrid	443	6	318	2	15/30	3	200	1	650
3	Business as Usual	1,191	-	-	-	-	-	-	2	68
	Microgrid	450	4	200	3	25/50	7	415	2	68
4	Business as Usual	190	-	-	-	-	-	-	-	-
	Microgrid	90	1	80	1	10/20	4	40	-	-
5	Business as Usual	304	-	-	-	-	-	-	-	-
	Microgrid	150	1	100	1	10/20	4	40	-	-
6	Business as Usual	722	-	-	-	-	-	-	2	150
	Microgrid	250	1	25	1	20/40	1	355	2	150
NER	Business as Usual	9,863	-	-	-	-	-	-	-	-
	Microgrid	3,540	1	10	1	50/100	6	4,572	-	-

2.3. Distributed Energy Resources Characterization

A variety of generation sources are planned for the community microgrid. They include the following:

- Combined Heat and Power (CHP)
- Solar Photovoltaics (PV)
- Energy Storage System (ESS)
- Building Load Control
- Energy Efficiency Measures (EEMs)
- Utility Grid
- Backup Generators

The EEMs that are planned for the Near Westside microgrid have been taken into account for the final sizing of the microgrid portfolio of resources. Estimates of EEMs are based on measures that have already been adopted in many projects conducted as part of the Near Westside Initiative, including retrofits to improve weatherization, high-performance lighting and heating, ventilation, and air conditioning systems, advanced building controls, variable-frequency drive motors, etc. Energy efficiency and adoption of emerging green technologies has been one of the signatures of projects conducted in the SALT District as part of the Near Westside Initiative. To date, three facilities that are targeted for inclusion in Node 2—King+King, Lincoln Supply, and WCNY—each earned LEED Platinum ratings and have exemplary EEMs incorporated into innovative adaptive reuse projects. In addition, four homes in the SALT District constructed as part of the Initiative have earned LEED Homes ratings (three Platinum and one Gold). Envisioned future EEM projects will leverage incentive programs whenever available. Deployment of EEMs ensures that the microgrid resources are not oversized.

CHP units will be located in targeted buildings that have appropriate thermal loads. Solar PV arrays will be located opportunistically on suitable rooftops, in parking areas, and in locations where opportunities for ground-mount arrays exist. Energy storage units will be sited near the solar PV arrays, with preference for indoor locations. Existing backup generators will be leveraged to support island operations in conjunction with the new DER. New DER will minimize the need for the backup generator operation to minimize natural gas and diesel fuel usage.

An overview of each technology, installation, operating strategy, and modeled operation are presented in this section.

2.3.1 Combined Heat and Power

CHP generators provide electrical and thermal energy from a single source. The use of fuel to generate both heat and power makes CHP systems more cost effective than traditional power generation. Most power generation produces heat as a byproduct, but because power is generated far from the end user, the heat is lost. CHP units take advantage of the fact that they are collocated with the end user, and make use of thermal energy for heating and sometimes even cooling nearby buildings. For this microgrid application, internal combustion engine based CHP systems have been modeled. Internal combustion engines, also called reciprocating engines, use a reciprocating motion to move pistons inside cylinders that turn a shaft and produce power. Internal combustion engines typically range between 5 kW-7 MW and are best suited for load-following applications. An image of an internal combustion engine generator is presented in Figure 2.3.

Figure 2.3 – CHP System Overview

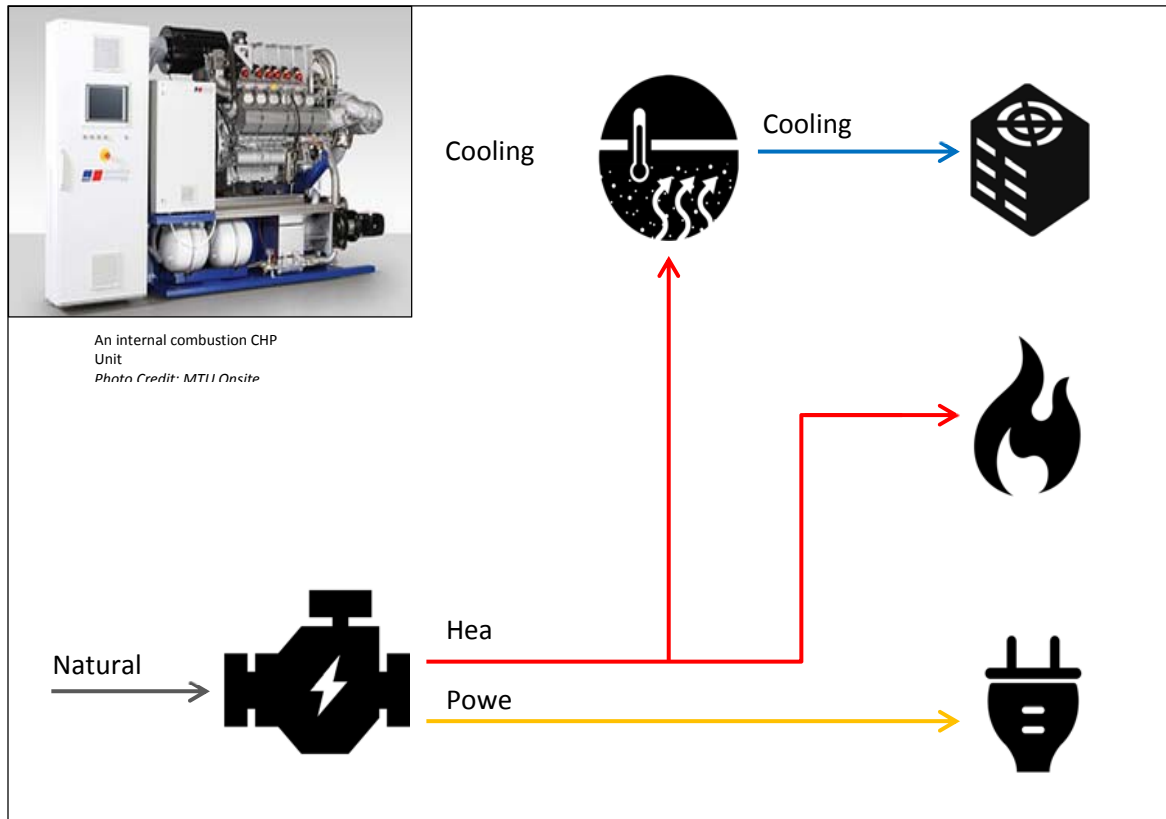

Benefits of CHP

- Reduces utility costs and improves economic competitiveness
- Increases power reliability and self-sufficiency
- Reduces GHG emissions and other pollutants
- Reduces demand for imported energy supplies
- Capable of operating on renewable or nonrenewable resources
- Suite of proven, commercially available technologies for various applications
- Additional financial incentives may be available through the NYSERDA and investment tax credits available for eligible customers

CHP Approach

- Co-locate generators near thermal loads on the customer-side of the meter
- Design for base load operation of at least 8,000hrs/yr, and to maximize heat recovery when grid connected
- Support microgrid operations when the electric grid is not available along with PV, energy storage, and building load control
- Design to serve specific winter Heat Recovery Loads, such as a boiler plant, space heating, DHW, and pool heating
- Design to serve specific summer Heat Recovery Loads, including space cooling, DHW, and pool heating

CHP in the Microgrid

The size and location of the planned CHP units is presented in the layout diagram and single-line diagram presented in the Appendix. Table 2.6 summarizes the CHP components by node of the microgrid.

Table 2.6 – Microgrid CHP Resources by Node

Node	Natural Gas Engine or CHP	
	Quantity	Total kW
1	2	10
2	3	200
3	7	415
4	4	40
5	4	40
6	1	355
NER*	6	4,572
Total	27	5,632

* Engine generators without heat recovery

The tables and figures below describe the annual operation of the CHP fleet in the Near Westside microgrid.

Table 2.7 – Microgrid Natural Gas Engine and CHP Electric Production by Node

Month	Node 1	Node 2	Node 3	Node 4	Node 5	Node 6	NER	Total
Electric Production (kWh)								
Jan	6,896	119,295	270,061	21,405	22,024	215,688	3,323,325	3,978,694
Feb	5,732	108,849	232,565	18,192	19,441	185,392	2,987,035	3,557,204
Mar	6,856	126,815	253,950	22,413	20,999	218,837	3,235,742	3,885,612
Apr	5,926	112,901	253,014	19,387	17,710	204,445	3,020,354	3,633,736
May	6,393	116,781	258,956	20,486	17,826	249,425	3,052,567	3,722,434
Jun	7,161	121,262	246,342	21,087	19,484	252,912	3,026,911	3,695,159
Jul	7,434	119,596	262,445	18,803	19,270	253,195	3,245,745	3,926,488
Aug	7,431	120,181	263,338	21,491	19,560	251,054	3,197,952	3,881,008
Sep	7,193	117,614	246,587	20,930	17,744	240,006	2,959,341	3,609,416
Oct	6,587	117,129	259,939	20,781	19,796	227,431	3,075,716	3,727,379
Nov	6,285	117,856	250,768	19,829	20,194	224,361	2,982,278	3,621,572
Dec	7,021	119,809	215,905	20,400	19,672	191,379	3,225,048	3,799,234
Total	80,914	1,418,089	3,013,869	245,204	233,722	2,714,125	37,332,014	45,037,938

Figure 2.4 – Microgrid Natural Gas Engine and CHP Electric Production

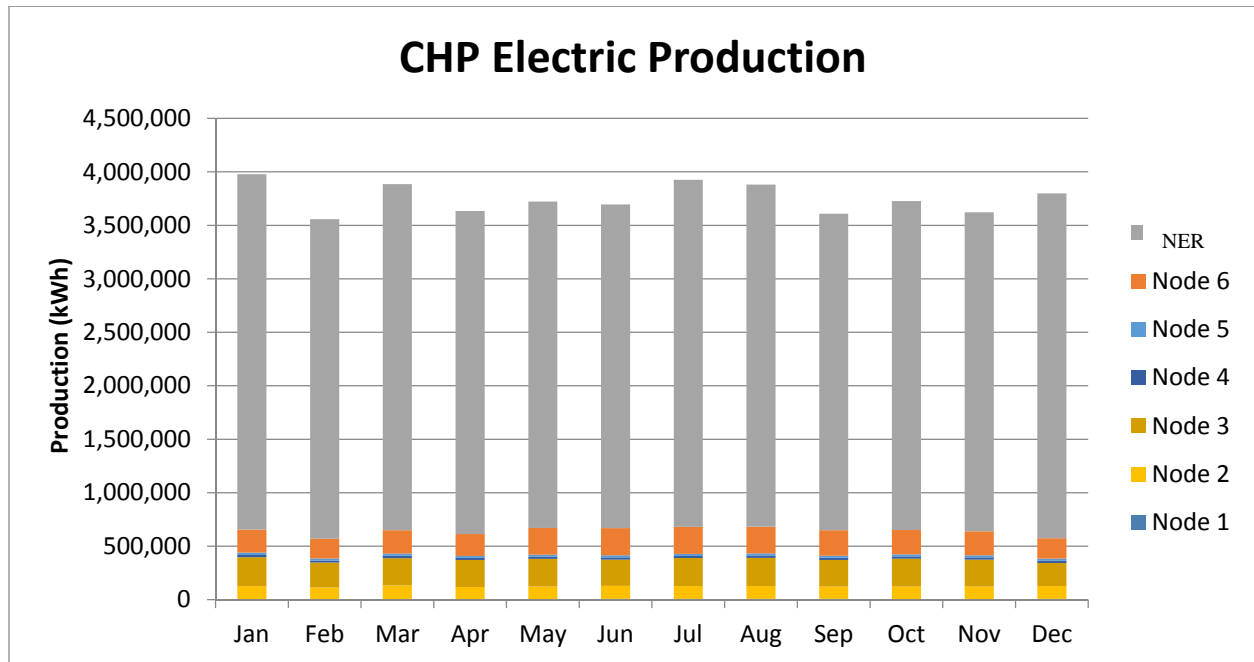

Table 2.8 – Microgrid CHP Heat Recovery by Node

Month	Node 1	Node 2	Node 3	Node 4	Node 5	Node 6	NER	Total
Heat Recovery (kBTU)								
Jan	30,544	47,875	1,314,650	76,142	78,343	1,104,060	-	2,651,613
Feb	25,385	42,964	1,143,771	64,711	69,155	956,951	-	2,302,936
Mar	30,344	54,246	1,243,057	79,725	74,697	1,079,441	-	2,561,509
Apr	24,537	43,279	1,184,003	68,961	54,128	897,666	-	2,272,575
May	16,813	43,935	1,091,828	72,430	14,523	966,707	-	2,206,237
Jun	3,923	25,515	753,258	52,682	3,826	921,815	-	1,761,019
Jul	1,889	17,312	465,367	41,740	1,145	840,228	-	1,367,681
Aug	3,501	24,660	715,762	55,883	1,376	741,783	-	1,542,964
Sep	8,362	42,214	952,305	74,066	3,889	670,668	-	1,751,504
Oct	25,789	45,724	1,212,079	73,920	62,880	880,432	-	2,300,824
Nov	27,825	46,720	1,230,054	70,536	71,834	1,127,791	-	2,574,759
Dec	31,084	46,659	1,050,226	72,567	69,977	968,152	-	2,238,665
Total	229,996	481,102	12,356,360	803,363	505,774	11,155,693	-	25,532,287

Figure 2.5 – Microgrid CHP Heat Recovery

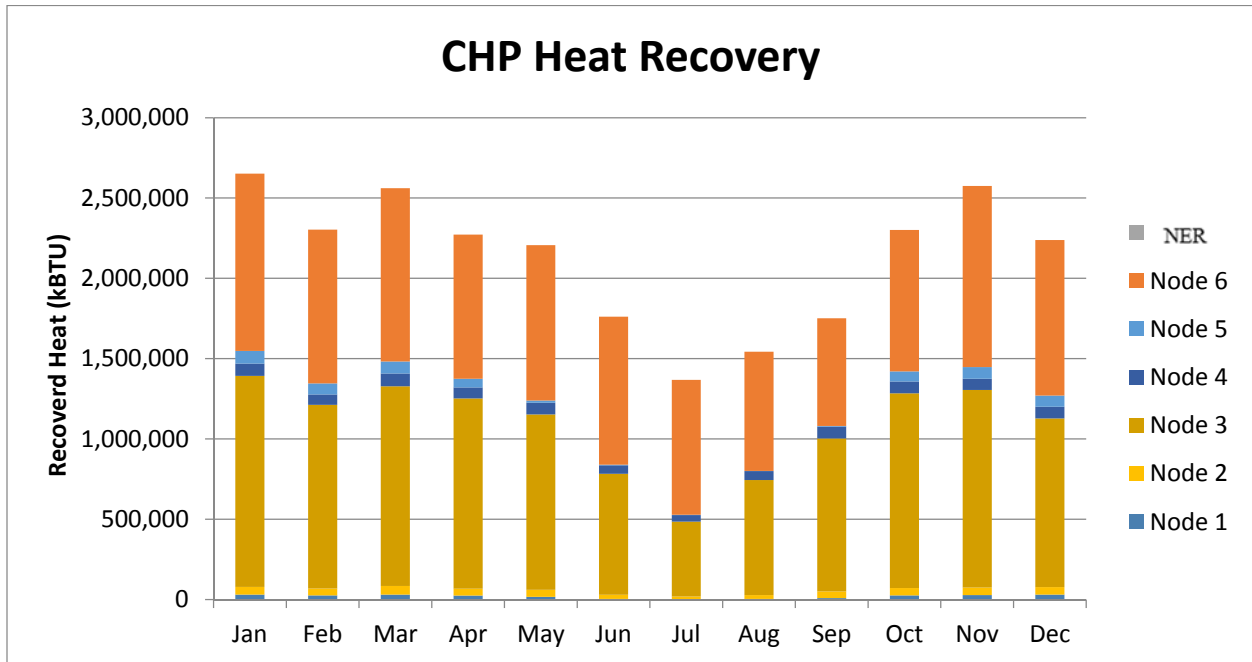
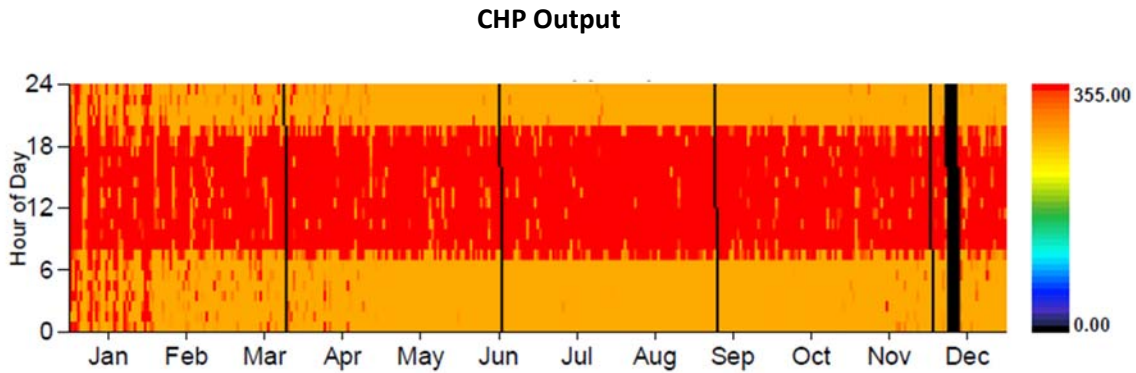

Figure 2.6 presents the hourly operation of the CHP in Node 3 in the form of a heat map. This representation demonstrates how the CHP unit is operating a near full capacity during normal business hours (red) and then does some electric load following during the non-business hours (orange) but is loaded at an overall high level of output during the course of the year.

Figure 2.6 – Node 3 CHP Operational Summary



2.3.2 Solar Photovoltaics

The solar photovoltaic systems (PV) will be rooftop, parking lot, or ground-mounted using hail-rated solar panels. PV devices generate electricity directly from sunlight via an electronic process that occurs naturally in certain types of material, called semiconductors. Electrons in these materials are freed by photons and can be induced to travel through an electrical circuit resulting in the flow of electrons to create energy the form of direct current. The direct current is transformed into usable alternating current through the use of an inverter. A typical customer-side of the meter PV installation is presented in Figure 2.7.

Figure 2.7 – PV Installation Diagram (Customer Side of Meter)

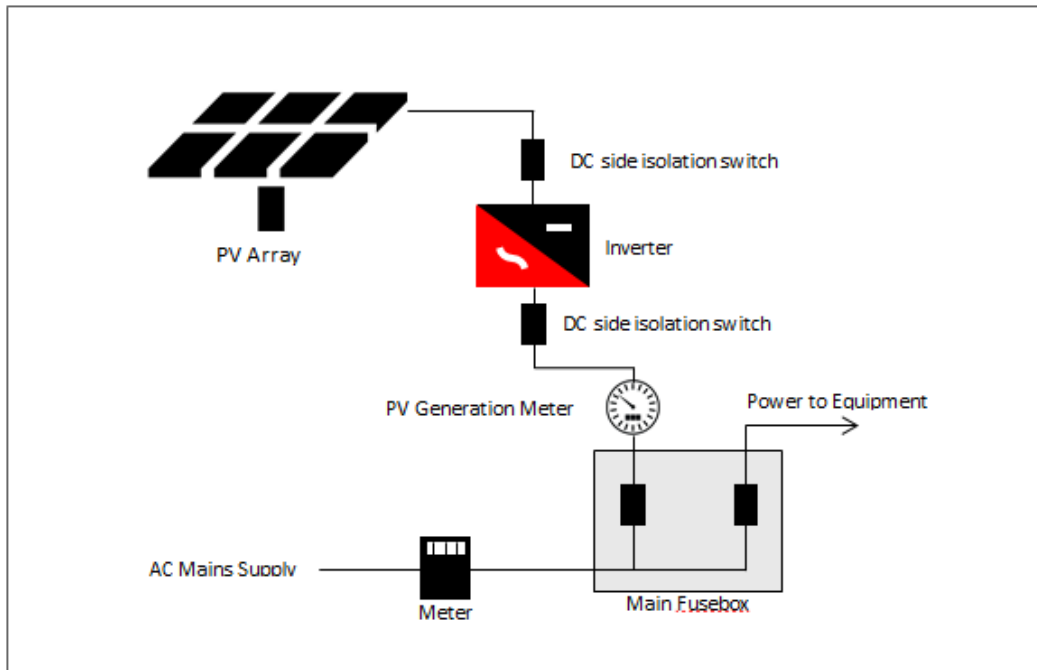

Since the PV systems are driven by sunlight, the electric production profile varies with the position of the sun and is impacted by the level of cloud cover. In addition, the model accounts for latitude and predicted snow loading on panels. Figure 2.8 presents the typical average daily PV generation profiles by month and demonstrates the seasonal variation of PV as a generation resource. The HOMER model takes this variability into account when simulating and optimizing the sizing of PV as a microgrid resource.

Figure 2.8 – Typical PV Daily Generation Profiles

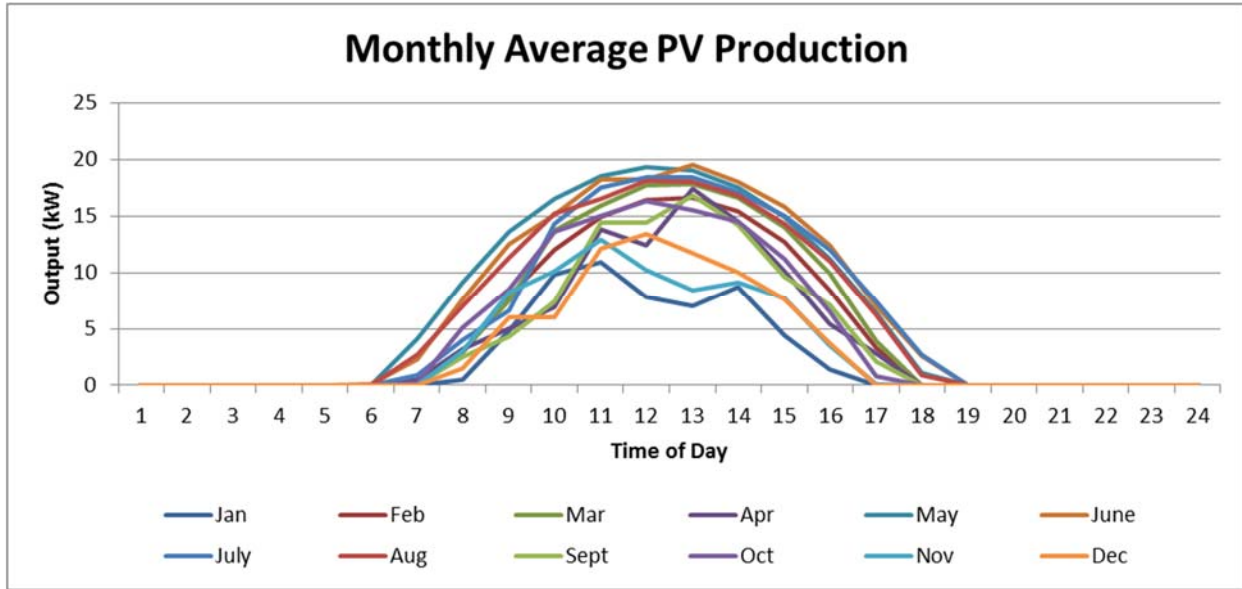

PV systems are planned for rooftops, parking spaces, and ground-mount configurations. Figure 2.9 presents examples of each these types of installations.

Figure 2.9 – PV Installation Options

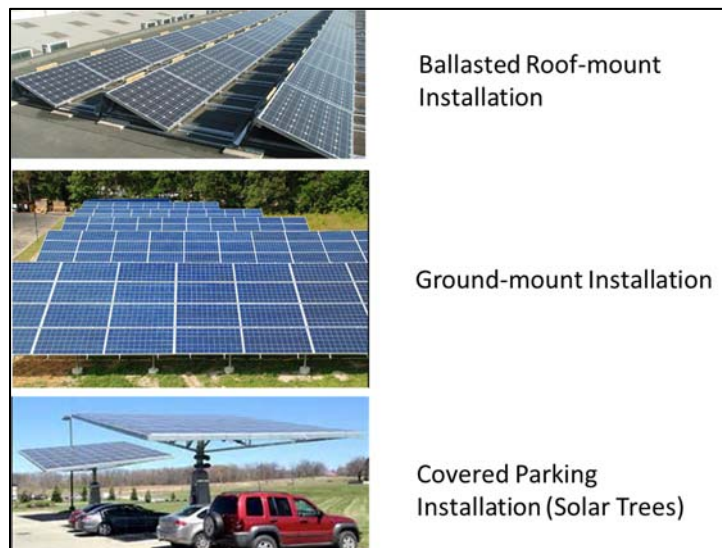

Benefits of PV

- Reduces utility costs and improves economic competitiveness
- Increases power reliability and self-sufficiency
- Reduces GHG emissions and other pollutants
- Reduces demand for imported energy supplies
- Fueled by a renewable resource
- Based on a suite of proven, commercially available technologies for a variety of applications
- Competitive market for hardware and installation services

PV Approach

- Co-locate PV systems on the customer-side of the meter to support resiliency
- Install on roofs, ground mount and covered parking
- Provide renewable energy resource (reduce site emissions and no fuel cost)
- Support day-time load requirements and annual energy loads (grid connected operation)
- Support microgrid operations when the electric grid is not available along with CHP, energy storage, and building load control

PV in the Microgrid

The size and locations of the planned PV systems is presented in the layout diagram and single-line diagram in the Appendix. Table 2.9 summarizes the PV components by node of the microgrid and includes the 138 kW of existing generation.

Table 2.9 – Microgrid PV Resources by Node

Node	PV	
	# of Inverters	Total kW
1	1	5
2	6	318
3	4	200
4	1	80
5	1	100
6	1	25
NER	1	10
Total	15	738

The below table and figures below describe the PV fleet. Total production is based on a capacity factor specific to solar production in Syracuse (13.55%).

Table 2.10 – Microgrid PV Fleet Electric Production

Month	Node 1	Node 2	Node 3	Node 4	Node 5	Node 6	Sub	Total
Electric Production (kWh)								
Jan	307	19,547	12,293	4,917	6,147	1,537	615	36,879
Feb	377	23,993	15,090	6,036	7,545	1,886	754	45,269
Mar	534	33,943	21,347	8,539	10,674	2,668	1,067	64,042
Apr	572	36,363	22,870	9,148	11,435	2,859	1,144	68,610
May	629	40,027	25,174	10,070	12,587	3,147	1,259	75,522
Jun	623	39,639	24,930	9,972	12,465	3,116	1,247	74,790
Jul	651	41,391	26,032	10,413	13,016	3,254	1,302	78,095
Aug	624	39,667	24,949	9,979	12,474	3,119	1,247	74,846
Sep	573	36,449	22,923	9,169	11,462	2,865	1,146	68,769
Oct	460	29,285	18,417	7,367	9,209	2,302	921	55,252
Nov	318	20,203	12,705	5,082	6,353	1,588	635	38,115
Dec	266	16,918	10,641	4,256	5,320	1,330	532	31,922
Total	5,934	377,425	237,370	94,948	118,685	29,671	11,869	712,111

Figure 2.10 – Microgrid PV Fleet Electric Production

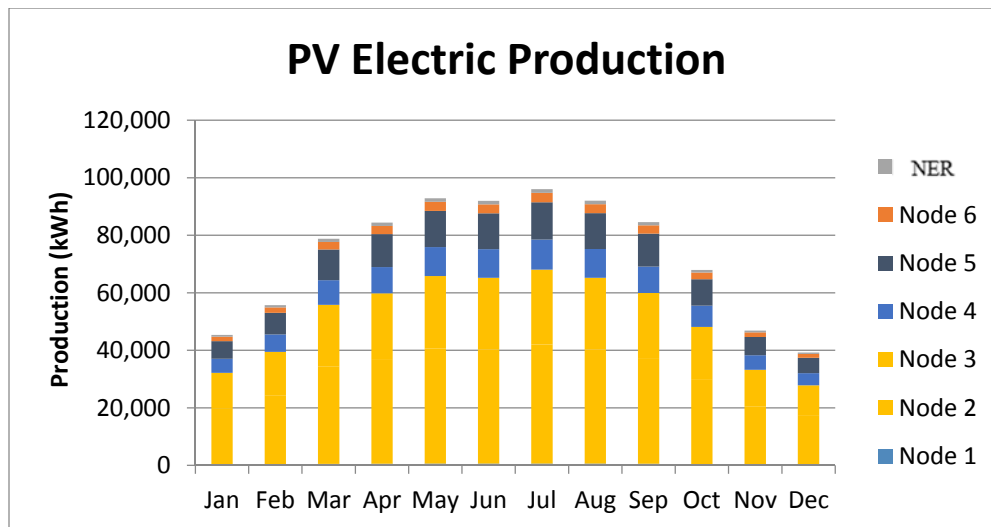
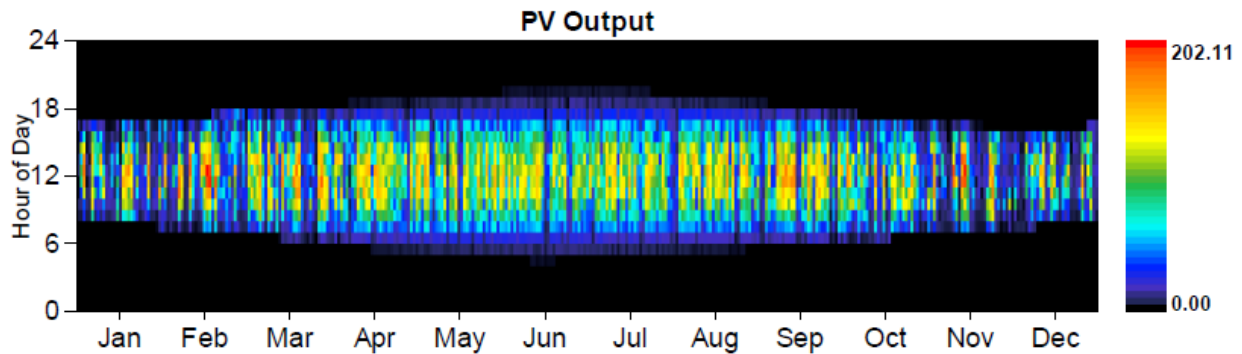

Figure 2.11 presents the hourly operation of the PV in Node 3 in the form of a heat map. This representation demonstrates how the PV units operate during hours of sunshine with maximum production in the middle of the day, ramping up in the mornings and ramping down in the afternoon

hours. This also illustrates the trend of narrower daily bands of production in the winter and then expanding to maximum production in the summer.

Figure 2.11 – Node 3 PV Operational Summary



2.3.3 Energy Storage Systems

Energy storage in a microgrid can improve the payback period for the whole system by enabling an increase in the penetration of renewable energy sources, shifting the energy produced by PV, enabling peak load management, managing PV intermittency, providing volt/VAr support, and supporting island mode transitions. The technology specified for the Near Westside microgrid is Lithium Ion (Li-ion) batteries, which have a fast reaction response to changes in load, a fairly small footprint and a relatively high round trip efficiency. Li-ion batteries have several unique operational characteristics:

- The usable energy capacity is between a 15% and 95% State of Charge (SOC)
- The life of the batteries are impacted by temperature and charge rate
- Most systems are capable of approximately 3,000 deep discharge cycles (+/- 80% SOC cycles)
- Most systems are capable of more than 100,000 shallow discharge cycles (+/- 15% SOC cycles)
- The batteries are at a high risk of failure if the system is discharged to a zero percent state of charge
- The systems typically have different rates (kW) for charge and discharge
- Most Li-ion systems have accurate methods of determining the system SOC
- Typical power electronic systems provide multiple modes of operation
- Systems are typically capable of four quadrant operation

Benefits of Energy Storage

- Reduces utility costs and improves economic competitiveness
- Increases power reliability and self-sufficiency
- Reduces GHG emissions and other pollutants
- Reduces demand for imported energy supplies
- Supports system with a high level of renewable energy penetration
- Based on a suite of proven, commercially available technologies for a variety of applications
- Competitive market for hardware and installation services
- Provides multiple functions and benefits to the microgrid:
 - Peak Load Management
 - Load Shifting
 - Frequency Regulation

- Reactive Power Support
- PV Support
- Demand Response
- Energy Arbitrage
- Backup Power

Figure 2.12 presents examples of energy storage installations for the technologies addressed for this microgrid design.

Figure 2.12 – Example ESS Installations



Energy Storage Approach

- Co-Locate with PV systems on the customer-side of the meter to support resiliency
- Install indoors or outdoors (indoor installation better for resiliency)
- Maximize functional benefits for the microgrid
- Support microgrid operations when the electric grid is not available along with CHP, energy storage, and building load control

ESS in the Microgrid

The size and location of the planned ESS systems is presented in the layout diagram and single-line diagram presented in the Appendix. Table 2.11 summarizes the ESS components by node of the microgrid.

Table 2.11 – Microgrid ESS Resources by Node

Node	Battery Energy Storage		
	Quantity	kW	kWh
1	1	5	10
2	2	15	30
3	3	25	50
4	1	10	20
5	1	10	20
6	1	20	40
NER	10	50	100
Total	19	135	270

Unlike the other microgrid resources, the ESS both consumes and produces energy. When properly used, the net energy consumed is very small. The annual operation of an example node (Node 4) is presented in Table 2.12, presenting both the charge and discharge modes of operation. The net value is positive which takes into account the operational losses for the systems.

Table 2.12 – Microgrid ESS Operation – Example for Node 4

Month	Charge	Discharge	Net
	(kWh)		
Jan	922	848	74
Feb	727	669	58
Mar	542	475	67
Apr	1,028	952	76
May	1,027	937	90
Jun	491	476	15
Jul	861	792	69
Aug	863	783	79
Sep	690	627	63
Oct	950	870	80
Nov	694	661	33
Dec	668	615	53
Total	9,462	8,705	757

Figure 2.13 – Microgrid ESS Operation (Node 4)

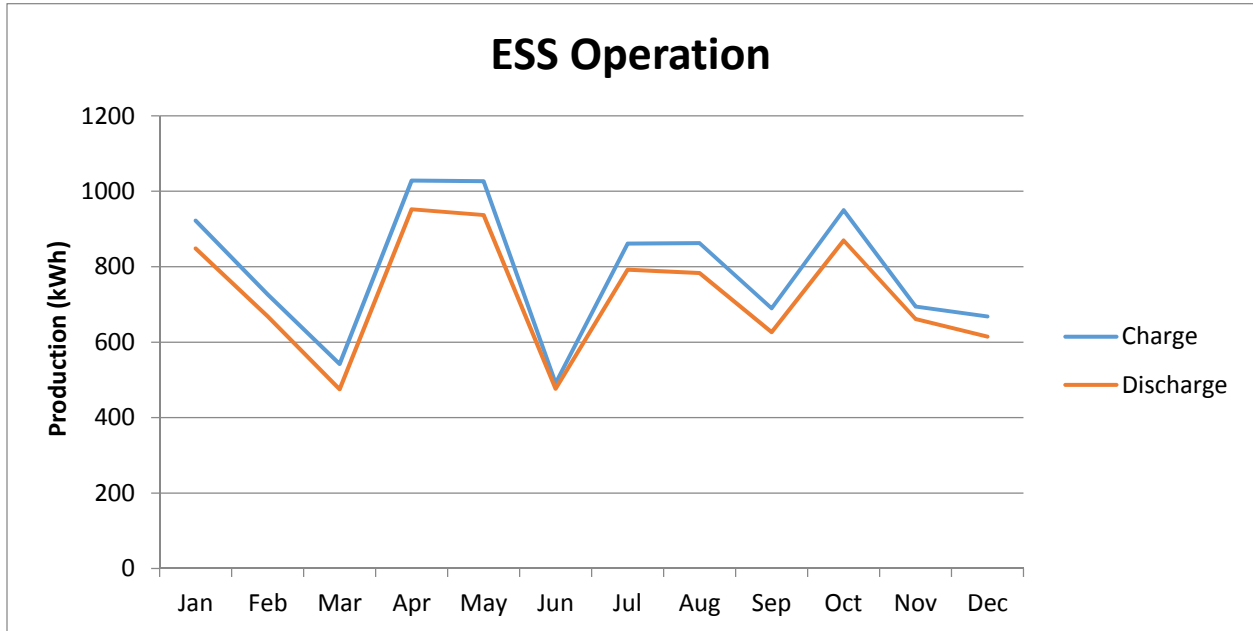
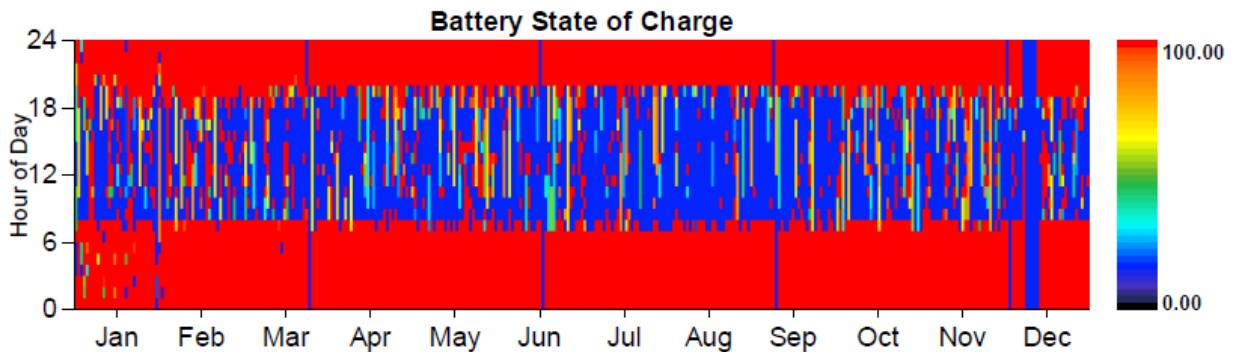

Figure 16 presents the hourly operation of the ESS in Node 4 in the form of heat map. This representation demonstrates how the ESS units operate. Typically, the units are charged to a high state of charge to start each day and then active during normal business hours. The operations represent PV intermittency support, PV load shifting and peak shaving (to manage utility imports).

Figure 2.14 – Node 4 ESS Operational Summary



2.3.4 Portfolio of Microgrid Distributed Energy Resources

The design for the Near Westside microgrid incorporates resources into non-intrusive areas available at critical facilities. Refer to the microgrid layout diagram (Appendix A) and one-line diagram (Appendix B) for general locations of resources.

The modeling of this microgrid indicates that the most economical total onsite DER generation requirement is in the range of 80 to 86% by energy (kWh) in grid-connected mode. Since specific DER sizes are discrete capacities, the matching of generation to load is imprecise, hence the range 80 – 86% by node site energy.

The electrical and thermal demand can also be modulated to meet total available DER production in a range of timeframes, from a few minutes to several hours. This modulation of load may have some comfort impacts, but will not impact mission critical functions within the critical facilities of the microgrid. In grid-connected mode, load modulation is not expected to take place unless driven by economic optimization, within the customer's stated objectives. In island mode, reliability and resiliency are the primary objectives, and load modulation may occasionally be used at certain times of the most energy-intensive days. If additional load modulation is needed, then critical facilities will be affected, but not in a way that would result in a material impact on the mission of that facility.

Upon loss of the grid, a "sliding scale" of importance of facilities in island mode will be used to make decisions about load modulation. During the first hours of a grid outage from a major storm, facilities providing emergency services (police, fire, emergency medical, hospital, etc.) will be prioritized. However, for extended outages, such as those during a major storm, other facilities may become "critical" with time. For example, by the second or third day, the need for medications and food may drive groceries and pharmacies onto the "critical" list. By the fourth day, gasoline for home generators, mobile phone charging, and cash may become very important to sustain shelter in place for residents, moving gas stations, ATMs, and warming centers onto the "critical" list.

This microgrid design is based on a portfolio of resources, including base generation driven by fuel delivered over resilient underground lines, PV operating when the sun is available (requiring no delivery), and energy storage systems (ESS) that store excess PV production for later use. Unlike an emergency diesel generator, this structure has no duration limit.

This microgrid design supplies all critical loads throughout the duration of a grid outage. In addition, some neighborhood community loads may continue to operate throughout the event when microgrid generation resources produce more energy than is required to serve the critical loads. Preliminary analysis suggests the sum of critical load and neighborhood community loads served in island mode will be about 80% of the normal total load.

Since the microgrid design eliminates the need for temporary generation such as backup diesel generators, it will protect the Near Westside facilities covered by the microgrid from the need to shared fuel and equipment with other communities, as is common during extended utility grid outages.

2.3.5 Microgrid DERs Resiliency

Under Task 1, our team assessed the resiliency risk profile for various forces of nature to inform the microgrid design. See section 1.1.11 of this report.

Based on our integration of photovoltaics, we conducted further analysis on how snow will affect PV performance. A recent national study conducted by NREL integrated a snow coverage model into NREL's System Advisor Model (SAM). The PV snow coverage model calculates the percentage of a PV array that will be covered by snow given system tilt, daily snow depth measurements, and hourly plane of array (POA) irradiance and temperature values. The model considers snow sliding to be the dominant removal process and therefore does not account for snow melting or wind removal (except in the case of flat fixed-tilt systems). Using hourly meteorological weather data (including daily snow depth measurements) for 239 locations across the United States, the study calculated losses due to snow for systems using both a fixed-tilt tilt-equals-latitude and a constant 20° tilt system design (Figure 2.15 shows results for 20° tilt). It was found that PV arrays in Syracuse, NY lost 12.8 +/-2.3% for systems with a tilt angle of 20° and 13.7 +/-2.7% for tilt-equals-latitude systems. These model results are consistent with anecdotal experiences of PV systems that are deployed in the Syracuse area. As the NY Prize Stage 1 analysis is intended to provide results that are accurate to within 30%, site-specific losses in PV

production were not incorporate into the preliminary model of the Near Westside microgrid. In the event that the project is advanced to a detailed design study, the team intends to include the NREL model in the more detailed design.

Figure 2.15 – PV production losses due to snow coverage using a constant 20° tilt system design

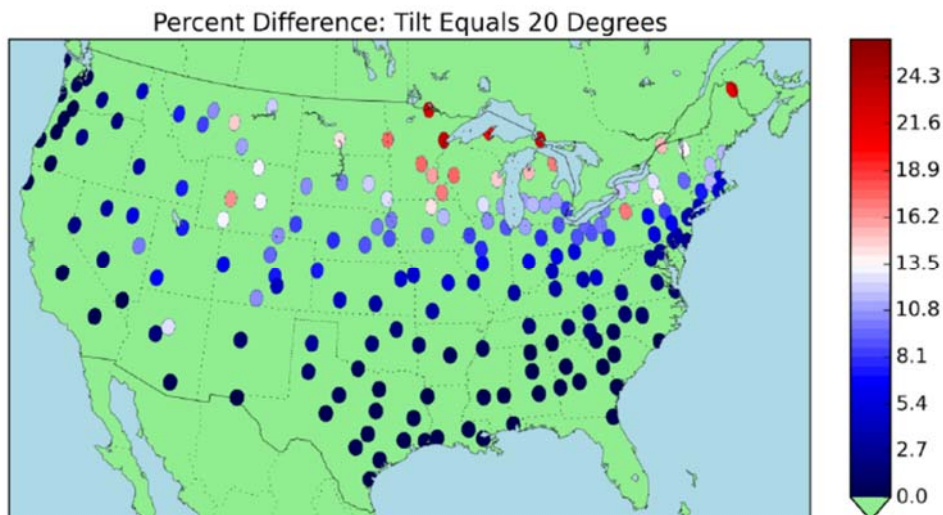

2.3.6 Reliability of Fuel Sources

Microgrid installations of natural-gas-fired generation systems at multiple locations provide opportunities to improve the quality and reliability of gas distribution that will benefit a wide range of customers throughout Near Westside.

The natural gas network is considered an uninterrupted fuel supply for the community in the face of major storms because:

- there are multiple network sources of natural gas;
- the actual natural gas network load decreases in a major storm because the neighborhood community loads are not operating; and
- there is no history of loss of service in past major storms

In addition, interruptible service is a financial construct, not a technical limitation. Home heating is considered the highest priority for continuity of supply in the face of challenges to the natural gas network. Since this microgrid will use natural gas for CHP (heating of critical facilities), it will be given the highest priority for continuity of supply in the face of a major storm.

The operation of the microgrid will minimize the use of existing emergency diesel generators and extend the typical three-day onsite fuel load for the emergency diesel generators to one week.

2.3.7 Microgrid DER Capabilities

The Near Westside microgrid design is focused on the development of an overall energy strategy that incorporates both demand-side management and new distributed generation resources to support the microgrid's operational objectives. During operation in the grid-connected mode, the resources will typically be dispatched in an economic optimization mode. This approach will ensure that the microgrid will operate in a manner that the energy delivered to the critical facilities is at or lower than that the cost of electricity that could be purchased from the local utility. In this scenario, the CHP will operate in a constant output mode at its maximum efficiency and lowest emissions, the PV generation profile will

be taken into account, the energy storage will operate in a manner to maximize microgrid benefits and the grid will operate in a load following mode. The connection to the grid will also be used to manage the voltage and frequency of the microgrid.

The microgrid will take advantage of DER to remain in operation when the utility grid is not available. The microgrid controller will monitor island mode frequency and voltage and adjust equipment operation accordingly to maintain circuit stability. The microgrid will also support the transition back to the grid when the utility service is restored. The design ensures that the return to the grid is a seamless transition, and is coordinated with the utility through appropriate protocols, safety mechanisms, and switching plans (to be communicated to the microgrid controller by the utility distribution management system).

To support steady-state frequency requirements, as well as the ANSI 84.1-2006 standard voltage requirements, and to support the customer power quality requirements at PCC, the microgrid controller will actively manage the dispatch of generation resources; actively manage the charge and discharge of energy storage; provide observability of microgrid-wide telemetry including frequency, power factor, voltage, currents and harmonics; provide active load management; and provide advance volt-VAR variability algorithms and other stability algorithms based on steady state telemetry of the system

2.4. Electrical and Thermal Infrastructure Characterization

The microgrid design employs underground cabling to support each microgrid node. The underground cabling is used internal to the node only and does not connect microgrid nodes. While this greatly improves resiliency within a microgrid node, the cost of the underground cabling limits the reach of the node. The utility feeders are mainly overhead lines, which cannot be relied upon in the event of a major storm. The same general protection schemes are employed in each microgrid node as are used in utility distribution networks (see Microgrid Protection Scheme below). Some pole-top transformers will be replaced with pad-mount distribution transformers, and additional isolating switches and breakers will be added at the PCC as described in Subtask 2.1.

Node 2 facilities currently are served at both 13.2 kV and 4.16 kV. The facilities served at 13.2 kV include DERs. As the majority of the load is served at 4.16 kV and it is desirable to have all facilities within a node on the same voltage and substation, the microgrid design includes changing several facilities from 13.2 kV to 4.16 kV. Since the net load as seen by the National Grid system is potentially less with the microgrid development, this change may have merit. The details and costs of this change in voltage source have been estimated, but would be solidified in the Detailed Design and Pre-Construction work (NY Prize Stage 2). Additionally, peak demand will be more thoroughly analyzed in Stage 2 to verify the ability of the 4.16 kV system to handle the peak. Possible solutions include added more microgrid DERs to supply a greater percentage of the energy.

Distributed energy resources will be added at the 480V level on-site behind the utility meter.

The existing thermal infrastructure consists mainly of hot water systems. If there is a steam system, we will not attach to it because the output temperatures of the natural gas engines used in CHP installations do not meet the temperature output standards to support a steam system. The CHP connections to the hot water systems are installed in parallel with the existing boiler and fed into the supply and return headers.

Table 2.13 – Microgrid Electrical and Thermal Infrastructure Plan

Proposed New Infrastructure	Class	Associated Device	Comment / Description
4.16 kV, 3 phase, 4 wire, Underground Cabling	New	All	Added for all Microgrid Nodes
PCC 1 (Node #1)	New	4.16 kV service from Node #3	Transition from overhead to underground
PCC 2 (Node #2)	New	4.16 kV service from Substation	Transition from overhead to underground
PCC 2 (Node #2)	Conversion	13.2 kV service from Ash Street Substation to 4.16 kV service from Fayette Street Substation	Convert electric supply to WCNY from the higher voltage Ash Street Substation to the lower voltage Fayette Street Substation so the all facilities in Node 2 are fed from the same substation and same voltage levels.
PCC 3 (Node #3)	New	4.16 kV service from Substation	Transition from overhead to underground
PCC 4 (Node #4)	New	4.16 kV service from Substation	Transition from overhead to underground
PCC 5 (Node #4)	New	13.2 kV service from Substation	Transition from overhead to underground
PCC 6 (Node #4)	New	13.2kV service from Substation	Transition from overhead to underground
4.16 kV Transformers	Updated	Critical Facilities	Conversion from pole-top to pad mount
Synchronizing Switches	New	CHP	Each CHP at a critical facility will require a synchronizing switch with protection to enable remote synchronization with the microgrid bus
M, C, P	New	All resources	Monitoring (sensing), Control, and Protection relays for proper management of resources in all modes
ATS	Existing	EDG and EGG	All emergency generation (diesel or gas) have automatic transfer switches installed in critical facilities. This will remain unchanged.
HW Supply Connection	New	CHP & heating	Tie-in from CHP to facility thermal loop for each facility with new CHP
HW Return Connection	New	CHP & heating	Tie-in from CHP to facility thermal loop for each facility with new CHP

2.4.1 Infrastructure Resiliency

The electrical infrastructure currently consists of overhead distribution lines with pole-mounted transformers. The microgrid design calls for one or more underground 4.16 kV circuits to be established within microgrid nodes from the points of common coupling. The team is in discussions with National

Grid to determine the most cost-effective approach for organizing and installing new underground segments. Critical new electric distribution infrastructure will be located in Nodes #2 and #3 where the microgrid distribution resources are shared among National Grid customers. In these cases, the common distribution segments are proposed to be undergrounded. For the other nodes, the microgrid distributed energy resources will be behind the meter of a single National Grid customer, and the node design will support standalone island operation when the grid goes down. The discussion of resiliency of resources to forces of nature in section 2.3 is relevant to electrical and thermal infrastructure as well. Outdoor switches for the underground electric distribution within the nodes will be installed in in-ground vaults. The natural gas infrastructure relied upon for resiliency is underground, which greatly reduces the risk of damage from forces of nature.

The process of islanding a microgrid can create a transient and added risk to reliable operations. To minimize this, the design incorporates a Point of Common Coupling structure will help to protect the microgrid from danger, as presented in the Section 1.1.4.

2.4.2 Microgrid Protection Schemes

The microgrid protection scheme is similar to a standard utility distribution-level protection scheme. However, since power flow is two-way in the microgrid and more actively managed, a more aggressive protection scheme is required. At every site where a resource interfaces with the microgrid (inverter, breaker, controller, etc.), the microgrid will feature a protection envelope with the following components:

- Underfrequency
- Undervoltage
- Overfrequency
- Overvoltage
- Phase to phase fault
- Phase to ground fault

Because of the two-way power flow within the microgrid, no reverse power trip protection is applied within the microgrid, except at the utility-side breaker (switch) at the PCC.

In addition, real-time droop algorithms and phase angle measurements are utilized to meet National Grid interconnection requirements. For example, with voltage-source energy storage, continuous phase angle correction is applied, which also enables power factor correction.

2.5. Microgrid and Building Controls Characterization

2.5.1 Microgrid Control Architecture

One of the challenges of community microgrids is that the facilities and the microgrid resources are distributed. To maximize the economics, reliability, and emissions reduction potential of the community microgrid, the microgrid controller architecture must have the capability to coordinate and control different groups of resources as well as provide control for localized operations.

Our team has developed a project concept for the community microgrid that allows for simultaneous control of multiple microgrids in the community as well as coordination with the local utility. Specifically, the solution includes local controllers in each microgrid node as well as a hosted controller in the Microgrid Network Operations Center (NOC) that can operate each microgrid node separately or collectively (Figure 1.6).

In the grid-connected mode, the primary operations will focus on maximizing economic benefits and minimizing emissions across all the microgrids within the community. In some cases, the aggregation of the microgrid resources can be leveraged to support utility firming request and/or ISO ancillary services such as demand response and frequency regulation. However, during a reliability event, the operation of each individual microgrid controller will focus on the load and generation assets only within its control. The local controller will transition to island mode while maintaining proper site voltage and frequency.

2.5.2 Control Capabilities and Services

The microgrid controller will have an active management and control architecture that supports the 10 EPRI/ORNL Use Cases:

In addition, the microgrid controller will:

- Forecast variable aspects: load, wind, solar, storage
- Dispatch of DER to maximize economic benefit
- Continuously monitor and trend health of all system components
- Take into account utility tariffs, demand response programs, and ancillary service opportunities
- Understand operational constraints of various DER and vendor-specific equipment
- Interface to local utility
- Meet rigid and proven cyber security protocols

Ultimately, the control system will perform all of the functions above to continuously optimize the operation of the microgrid for economic, resiliency, and emissions performance.

2.6. Information Technology (IT)/Telecommunications Infrastructure Characterization

2.6.1 IT Infrastructure

A microgrid controller design needs to be reliable and have reliability performance comparable to the other microgrid resources. A standard controller approach such as central controller or programmable logic controller (PLC) design will therefore not be sufficient. The architecture must support the capability to interface with field devices, provide a platform for communications and data management, provide for both local and remote operator access, have a data historian, and provide for applications to meet the microgrid Use Cases highlighted above. A conceptual controller topology is presented in the Figure 2.16.

Figure 2.16 – Conceptual Microgrid Controller Topology

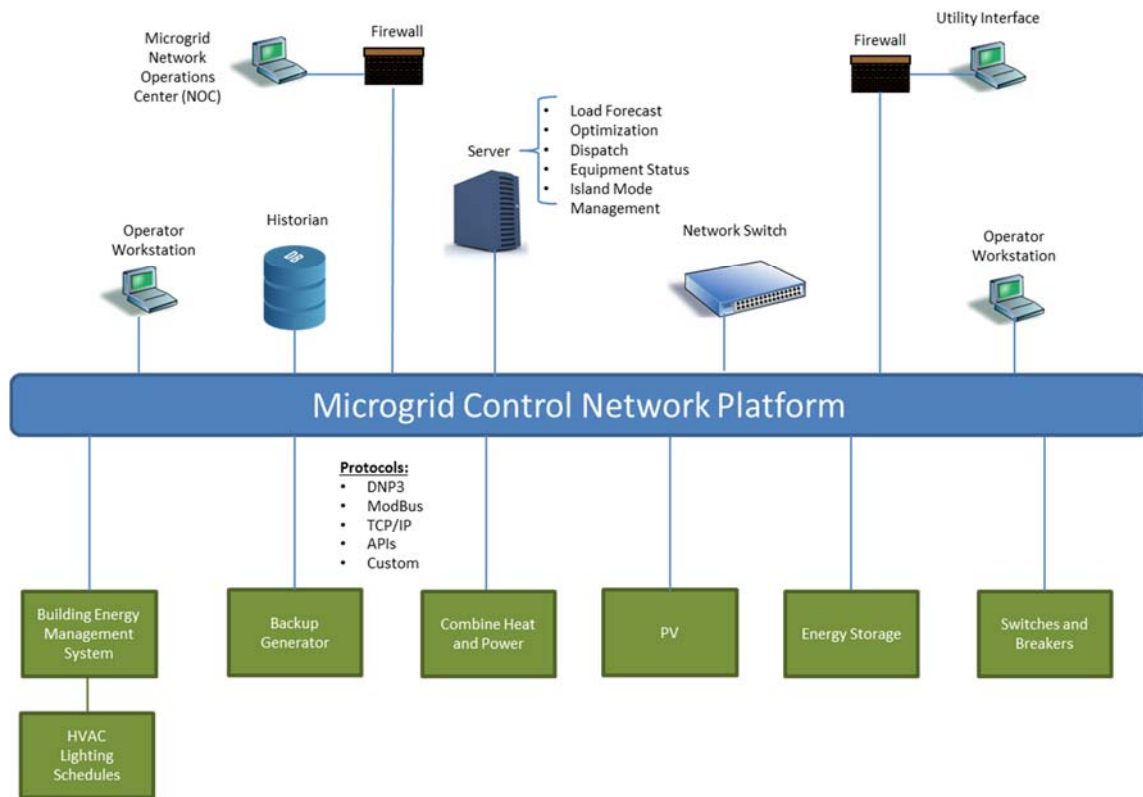

To support the community node approach, the microgrid control scheme will provide for a secure external access to the NOC that can coordinate the various nodes within the community. In addition, remote access for utility use will be provided to inform them and their distribution operators of the microgrid status and to communicate protection relay permissive messages for the island-mode transitions. The system will be designed so the core control functions are located within the microgrid and so that loss of communication with the NOC will not significantly impact the local operations of any node. The NOC monitors equipment performance and coordinates across nodes. In the event of an outage, all control will move to local controllers and focus on site specific optimization and operations.

The microgrid controller will leverage existing equipment to the greatest extent possible. This will include building energy management systems, backup generators, and local area networks. For the purposes of reliability and security, the microgrid control system will consist of new and independent infrastructure.

2.6.2 Telecommunications Infrastructure

Each microgrid node will have a wireless LAN specific to the microgrid, powered by microgrid resources, and extended to every resource, device, sensor, and load interface (e.g., building management system). This communications infrastructure will be designed with dual-redundant access points to assure reliable onboard communications.

The architecture will conform to requirements established by the Smart Grid Interoperability Panel (SGIP) and generally accepted communications protocols, such as ModBus (TCP/IP), DNP3 (TCP/IP), and IEC61850, as well as field networks for buildings such as LonWorks and BACnet. ModBus will be used throughout the microgrid nodes for communications since it is currently the most prominent

communications protocol within the DER and inverter community. Communications with the utility distribution management systems will use DNP3, since that is the prominent protocol used by the utility industry.

In addition, the NIST IR 7628, “Guidelines for Smart Grid Cyber Security,” will be followed in the architecture and design of the microgrid controls IT and communications to assure security and continuity of operations in all modes. Finally, the IT/telecommunications infrastructure will be new to secure the microgrid controls network separately from existing IT and communications systems at the facilities.

2.6.3 Communications – Microgrid and Utility

Communications between the microgrid and the utility will occur in two forms: (1) utility distribution management system (DMS) will interface with the microgrid controls for monitoring and managing the PCC utility-controlled isolating switch and microgrid-controlled synchronizing breaker, and (2) a dashboard served by the microgrid controls to the utility via the internet will give the utility insight into the day to day operations of the microgrid.

In accordance with the EPRI/ORNL Microgrid Use Case 4, the microgrid will transition into island-mode operations upon loss of communications between the utility DMS and the microgrid, assuming loss of grid. No specific microgrid action will be taken on loss of the utility dashboard service via the Internet.

The microgrid control system will be local to the microgrid node in a secure, conditioned space, (e.g., electrical room) in one of the critical facilities within the microgrid node. This assures that real-time control of the microgrid resources and loads will be maintained in the event of a loss of communications with the utility DMS and Internet services. Although economic optimization will be reduced for a period of time, the reliability and resiliency optimization will be maintained because those algorithms are in the microgrid control system local to the microgrid node and do not require off-board communications to function.

The onboard communications within the microgrid LAN will be a dual-redundant architecture, where every LAN access point is backed up by another access point.

Task 3. Assessment of Microgrid's Commercial and Financial Feasibility

3.1. Commercial Viability – Customers

The Near Westside neighborhood includes a cluster of facilities that provides an attractive opportunity to develop and demonstrate an innovative microgrid that has the potential to be a replicable model for similar neighborhoods throughout the State. The “Syracuse Arts, Literacy and Technology (SALT) District”⁹ in the northern third of the neighborhood includes six facilities that provide critical services to residents of the broader neighborhood and a diverse mix of uniquely owned and/or controlled buildings that has the potential to act as a group of interconnected loads and distributed energy resources. In addition, the area includes several vacant or underutilized properties that provide opportunities for attracting economic development via renovation, adaptive reuse, and/or new construction projects as

⁹ The Near Westside Initiative (NWSI) is committed to combining the power of art, technology and innovation with neighborhood values and culture to revitalize the SALT District of Syracuse's Near Westside. NWSI is a not-for-profit organization operated out of the Office of Community Engagement and Economic Development at Syracuse University that leverages the resources of SU, the state, the city, private foundations, businesses, not-for-profit corporations, and neighborhood residents to achieve its goals.

envisioned in a redevelopment plan for the SALT District that earned a Stage 1 Gold rating in the pilot LEED for Neighborhood Development (LEED-ND) rating system.

3.1.1 Customers and Stakeholders

The Near Westside neighborhood microgrid will serve a mix of critical facilities, residential customers, non-profit organizations, and businesses (commercial and industrial).

Critical Facilities

There are six critical facilities serving the population in the microgrid area:

- **Fire Station #6** – Located at 601 S. West St.
- **Syracuse Police Department team-oriented station** – Located in Rockwest Center at 1005 W. Fayette St.
- **Saint Joseph’s Primary Care Center West** – Located at 321 Gifford Street, this facility provides primary health care for children and adults and offers 24-hour on-call physician coverage, seven days a week. More than 75% of the Center’s 8,500 patients have Medicaid, Medicare or no insurance and more than 65% percent are Hispanic, African-American/Black, Asian-American or Native American.
- **Schools (3)** – The three schools in the microgrid area (Fowler High School, Blodgett School, Seymour Dual Language Academy) provide shelter to residents who are displaced during storms and power outages. Additionally, the schools serve nearly 2,000 students and approximately 250 staff members. Blodgett School is home to 434 students and 63 staff, Seymour Academy supports 581 students and 84 staff, and Fowler High School is home to 951 students and 107 staff.

Residents

The microgrid will serve the critical facilities and the approximately 7,000 residents of the Syracuse Near Westside neighborhood, which includes a large population of low-income and fixed-income residents who depend upon the critical services of the fire station, police substation, medical center, supermarket, and other resources in the microgrid. Low income, high disability rates, and low mobility make a sheltering-in-place response to extended grid outages and their aftermath a benefit to the community.

For example, the three high-rise apartment buildings in the James Geddes Housing Development (owned by Syracuse Housing Authority) are home to 269 vulnerable elderly and/or disabled residents, which make these facilities a high priority for providing shelter-in-place emergency response services which can be made more resilient through a local microgrid application. Further, three blocks that include all of the James Geddes Housing Development residences within node #3 of the microgrid serve approximately 900 residents. Providing these residences resilient power during outages avoids the risk and disruption of relocating individuals to other areas in the city.

Businesses and Non-Profits Organizations

Multiple businesses and non-profit organizations will be customers of the microgrid. These entities will benefit from more stable electricity rates and improved resiliency offered by the microgrid. Additionally, they will avoid the direct financial and operations disruption related costs they would incur during grid outages. These facilities include:

- **WCNY** – Home to not only the local public broadcasting station but also local public radio and hosts the data services for 13 public broadcasting stations from around the country. WCNY employees ~50 individuals in public broadcasting and information technology services. WCNY also broadcasts emergency alerts via TV and radio and thus provides an important function during storm events.

- **King & King Architects** – This architecture firm employees ~50 highly skilled individuals in architecture services and is a strong supporter of the Near Westside community.
- **Nojaim Bros. Supermarket** – This Independent grocery store has been in the neighborhood for 50 years and recently completed a \$2.65-million renovation to upgrade and expand the store. Employing ~50 individuals in the only full service grocery store in the area, Nojaim’s provides fresh food choices in what would otherwise be a food desert for the community residents.
- **SteriPharma** – This company manufactures cephalosporin pharmaceutical products for U.S. and International Markets. The facility is 75,000 square feet in total with 30,000 sq ft dedicated to manufacturing.
- **St. Lucy’s Church** – This church is a major resource for the Near Westside and is home to several ministries devoted to helping the community by providing nutritional support, low-cost clothing, support for the homeless, and many other services
- **Lincoln Supply** – This mixed-use facility was renovated from the historic Lincoln Supply building and houses two floors of commercial space and 10 apartments on the upper two floors of the building. Lincoln Supply includes Central New York Care Collaborative, Giovanni Quattrone Studio, and La Casita Cultural Center Project.
- **P.E.A.C.E., Inc.** – This non-profit community-based organization has a mission of helping people in the community realize their potential for becoming self-sufficient and is Onondaga County’s Community Action Agency. Services include energy efficiency, housing, food pantries, transportation, tax education and assistance, community services, senior services, and more.
- **CNY Services – Homestead** – This Center provides long term housing for adults with serious and persistent mental illness within a private apartment structure. On-site staff provides services including medication management, crisis intervention, activities for daily living, social, and recreational opportunities.
- **Hillside Children’s Center** – Hillside Family of Agencies’ integrated system of services addresses the varied, diverse, and complex needs of children and families including work-scholarship services, home and community based services, treatment for children and adolescents with severe emotional challenges, and family development services
- **Gifford & West Pharmacy** – The only pharmacy in the community, Gifford & West Pharmacy has been in the community for more than 30 years and is locally owned and operated by pharmacists dedicated to meeting the increased healthcare needs of the community.
- **Huntington Family Center** – This neighborhood-based, multi-service agency responds to a wide range of social and neighborhood problems. Huntington provides services to people faced with problems caused by inadequate education, unemployment, sub-standard housing, developmental disabilities, and discrimination based on race, gender, handicap, or socio-economic status.
- **Delavan Center** – Delavan Center is home to over 30 artists, professionals and their businesses in painting, illustration/web/graphic/print making, photography, ceramic/glass, textiles/clothing, jewelry, and wellness.
- **Rockwest Center** is home to several business including:
 - **Oneida Air** – A rapidly growing manufacturer in Syracuse’s Near Westside, sales recently tripled for the small company and they anticipate growing from 60 to 120 employees by summer 2016.
 - **Practice Resources, LLC** – The largest tenant provides Physician’s Practice management Services, practice transformation, revenue cycle management, and information technology management. PRL provides these services to over 350 health care providers throughout New York State in over 85 locations. PRL

- employees over 85 individuals in a growing business.
- **Syracuse City School District Teacher Center**
- **Say Yes to Education**
- **O Yoga Studio**
- **Clayscape Pottery**
- **Handprints gift shop**
- **SaltCity Signs**

All the critical resources and businesses listed above are expected to purchase services from the microgrid. It is expected that Syracuse Housing Authority will purchase services from the microgrid for the James Geddes Housing Development. Other individual residential blocks in the neighborhoods that may be served depending feasibility with the utility are shown in the Appendix.

In addition to the potential customers identified above, the Syracuse Near Westside microgrid feasibility study will create benefits for all other stakeholders in the Community, as outlined in Table 3.1.

Table 3.1: Organizational Benefits

Organization	Benefits from the Near Westside Microgrid
National Grid	By serving the local load and resiliently providing energy, the system will allow the utility to delay substantial investments in the existing Fayette Substation. Loading on feeders from Fayette and Ash street substations will be reduced by the presence of the microgrid. The Project will also help National Grid meet its customer-sited renewable energy target under the New York’s Renewable Portfolio Standard. National Grid will have an opportunity to develop and test the business and operational interfaces (such as the Distribution Service Provider – DSP function) needed to fulfill the objectives of the NY Reforming the Energy Vision (REV) transformation program. ¹⁰
Near Westside Initiative	This organization, with a mission to foster economic development, jobs and stability for the Near Westside neighborhood, will benefit from the microgrid. Having cleaner, more resilient power in this neighborhood will be a positive feature that can be used to attract residents and businesses.
Syracuse Center of Excellence (SyracuseCoE)	SyracuseCoE promotes excellence in environmental and energy systems innovations in New York State. Professionals from throughout the state and across the country come to SyracuseCoE to learn more about the potential of new technologies and approaches. Having a successful microgrid a short distance from SyracuseCoE’s headquarters will allow the staff there to demonstrate real-world examples of the microgrid solution.
Syracuse University	The process of building and operating a microgrid represents a significant learning opportunity for students and faculty. The project team anticipates that an operating system would have a symbiotic relationship with the University – providing learning opportunities while benefitting from University research on system performance. In fact, students from the university have already participated in elements of the feasibility assessment.

¹⁰ The REV goals include: affordable energy, resilient energy systems, improving utility infrastructure, reducing greenhouse gases among others.

3.1.2 Ancillary Services, Direct, and Indirect Benefits

The microgrid for Syracuse's Near Westside neighborhood is being conceived at the dawn of a new era in energy systems. The approach is envisioned to be a widely replicable approach that will be attractive for thousands of similar inner city neighborhoods in post-industrial cities in New York State, across the country, and around the world. The approach is focused on serving customers in the neighborhood, providing greater resilience and savings in energy costs. While the approach does not require sale of ancillary services for financial viability as the market evolves, it is certain that Distributed Energy and Capacity Resources (DER) will increasingly impact the planning and operation of the power system. Based on recent decisions in the state of New York, evolving business structures are expected to create new opportunities for the envisioned Near Westside microgrid to provide services that have the potential to make the project more attractive to investors and lower costs to customers.

On January 21, 2016 the New York Public Service Commission (PSC) issued an order "Establishing the Benefit Cost Analysis Framework for DER."¹¹ This order sets out the major conclusion that DER should be compensated based on the Societal Costs Test (SCT).¹² The PSC adopted the SCT as the primary measure of cost effectiveness. The SCT recognizes the benefits of a DER on society as a whole. The NY PSC concluded that this is the proper basis for benefit valuation. New York's clean energy goals are set in recognition of the effects of pollutants and climate change on society as a whole, and only the SCT properly reflects both the related policy objectives and creates a framework for meeting those broader goals.

Essential Reliability Services

The essential services needed for reliable operation of the delivery system include load balancing, voltage support, and frequency response after disturbances. These services are needed in order to foster better forecasting of production and load, create visibility, and enable participation of DER as an active part of the electric delivery system. On December 17, 2015 The North American Electric Reliability Corporation (NERC) issued its report on Essential Reliability Services. This report noted that the significant transformation of the power system is underway, shifting away from central station generation to distributed resources, including demand response. Recognizing that these changes represent a fundamental shift in the operational characteristics of the power system with potential reliability implications, NERC assessed the impacts and identified measures to monitor continued grid reliability and resiliency.¹³ The report examines the key building blocks of power system reliability. It identifies frequency control, voltage support, and ramping capability in response to net customer load changes. It is expected that the ancillary services market development and business structure redesign under both state and federal jurisdictions will respond to this technical input.

Specifically in New York, the NYISO is in the process of amending its tariffs to permit direct DER participation in the bulk power markets from "behind the meter." The tariff changes are expected to monetize these services so that microgrids providing these services can participate in the wholesale

¹¹ The NY DPS REV related orders and the DER Benefit Cost Analysis Order can be found at:

<http://www3.dps.ny.gov/W/PSCWeb.nsf/All/C12C0A18F55877E785257E6F005D533E>.

¹² The SCT recognizes the impacts of DER or other measure on society as a whole, and has been determined by the NYPSC as the proper valuation test.

¹³ NERC ERS Report Abstract available at:

<http://www.nerc.com/comm/Other/essntlrlbltysrvdstskfrDL/ERS%20Abstract%20Report%20Final.pdf>

electricity markets. The US Supreme Court recently upheld FERC Order 754 which had been challenged by states.¹⁴

Successful implementation of DER will ultimately require new market structures as being developed by the NYISO (subject to FERC jurisdiction) and through the NY REV Proceeding. These proceedings will monetize benefits at the local distribution node. The services and benefits potentially provided by Distributed Energy and Capacity Resources (DERs) in the form of microgrids to a market construct include:

NYISO market services:

- Installed Capacity
- Energy
- Ancillary Services

Customer benefits

- Net reduction in energy delivery and supply costs
- Tailored and improved reliability performance (metrics such as SAIFI, SAIDI CAIDI, Momentary outage reductions)
- Resilience in the face of catastrophic events

New York Independent System Operator (NYISO)

The NYISO functions as the statewide reliability coordinator and system planner. The NYSIO independently operates three key markets of interest to microgrid developers and DER operations. They are the:

- Installed Capacity Market
- Energy Market
- Ancillary Services market.

Installed Capacity Market

The Installed Capacity (ICAP) Market is established to ensure that there is sufficient generation capacity to cover the capacity requirements determined by the NYISO. An ICAP resource is a generator or load facility that is accessible to the NYS transmission system, which is capable of supplying and/or reducing the demand in the NYCA and complies with the requirements of the reliability rules.

Energy Market

The energy market provides a mechanism for Market Participants to buy and sell Locational Based Marginal Price (LBMP) energy and to bid various kinds of bilateral transactions. Suppliers may sell energy directly into the market at LBMP or be party to a bilateral contract selling directly to purchasers. Load Service Entities (which may include microgrids) and others may purchase energy at LBMP by submitting bids and/or they may be party to a bilateral contract purchasing directly from a supplier.

¹⁴ The U.S. Supreme Court upheld the Federal Energy Regulatory Commission's (FERC) authority to design rules and incentives for reducing electric load as seen by the utility during periods of high electricity demand. Known as "demand response," it is employed by utility system operators (such as the NYISO) when energy is expensive and/or when the delivery system is stressed. Demand response adds significant resilience to the electric delivery system. Microgrids are expected to be one form of demand response provider under the wholesale electric market business model.

See: http://www.supremecourt.gov/opinions/15pdf/14-840_k537.pdf

Ancillary Services Market

Ancillary services support frequency control, provision of voltage support to maintain the operational reliability of the power system.

The NYISO has received FERC approval for changes to its tariffs that will provide direct access to its wholesale market structure for prospective behind the meter net generation that meets the terms and conditions of its tariffs. These changes will permit DER to have a fair opportunity to directly compete with other energy and capacity providers in the wholesale electricity markets and receive fair compensation to the extent their electrical performance and production characteristics meet the terms and conditions of the NYISO tariff. For instance the NYISO Services Tariff condition BTM:NG resource participation in the Installed Capacity (ICAP) market conditioned on satisfaction of NYISO's deliverability requirements. While specific distribution level nodal pricing cannot at this time be fully determined, it is clear that the market based benefits upon which DER will be compensated will have an opportunity to be fairly determined through the operation of wholesale markets in addition to any benefits conferred through other state policymaking efforts such as the PSC REV proceeding.

National Grid – Transmission and distribution local utility service provider-specific example of benefits

Investor owned utilities in New York in general no longer provide generation. The generation service is provided through the NYISO markets or through bilateral contracts for power.¹⁵ Under Public Service law the “last mile” of delivery service In New York is provided via price regulated electric corporations must furnish and provide delivery service and facilities that are safe and adequate and in all respects just and reasonable in terms of cost and uniformity of service.

Although currently under review and development,¹⁶ the fundamental pricing model for local utility service providers is a rate of return on investment based regulatory construct based solely on utility plant and property. Externalities such as environmental benefits are not considered in the pricing model. The NY REV case is moving in a direction to change this construct.

However the obligation to serve as the sole provider of electricity locally to customer locations reflects the floor of the costs against which DER is to be judged.

The primary driver of incremental need for utility transmission and distribution investment is additional incremental load during a single hour of system peak demand. However, need for marginal investment in the utility's transmission and distribution systems can change substantially depending upon where load and any local DER is connected.

For example, the need to upgrade a transmission line primarily depends upon whether incremental load placed on the transmission system occurs (and adds to the system load) during the peak demand hours for the facilities of interest.

In contrast, the incremental need to build additional distribution, including secondary (120-480 volt) delivery assets, is more dependent upon the local customer's peak demand and not the coincidence of the customer demand (or net demand after local distributed generations is applied) with the utility system peak demand. When estimating the cost of serving a load addition or reduction, whether or not such load would actually trigger additional infrastructure need should be considered based on the load's time of use characteristics of, and the imposition of, its service requirements on the utility equipment that serve it.

¹⁵ The only exception being that the New York Power Authority remains a vertically integrated G&T utility.

¹⁶ See NY Public Service Commission's Reforming the Energy Vision (REV) Proceeding at: <http://www3.dps.ny.gov/W/PSCWeb.nsf/All/C12C0A18F55877E785257E6F005D533E?OpenDocument>

Currently, in the discharge of their duty as electric corporations, utilities generally operate their asset management functions on the following asset allocation principles with the objective that the system be operated and planned to meet the most severe delivery obligation criteria for public safety and service reliability including quantity and quality of power delivered.

The asset management process that drives toward this result continually reviews asset health and makes spending (capital, retirement and O&M) decisions regarding assets in accordance with the following typical steps:

- 1) Economically and reliably maximize the utilization of the assets currently in place to solve a given operating or planning criteria violation.¹⁷
- 2) Economically and reliably maintain the assets being utilized
- 3) Economically and reliably retire the assets no longer needed to provide service in accordance with operating and planning criteria.
- 4) Economically and reliably apply operating procedures to address criteria violations when the operating procedure is more economic than each or all of steps 1, 2, 3
- 5) Only after steps 1, 2, 3 and 4 are applied and exhausted will the asset base currently in place be expanded or replaced to solve a given operating or planning criteria violation.

As DER potentially fulfills a greater role in how energy is generated (locally), consumed (locally), and managed (locally), there are many effects on the business of power delivery. All upstream facilities including distribution, transmission and generation assets, along with the various levels of system planning and operations benefit from a loading and voltage support perspective by having more DER close to load.

DER resources close to load reduce the amount of electricity that must be transported over upstream delivery systems allowing utilities to avoid, reduce, or delay upstream delivery system investment.

Utilities and regulators in New York are actively working towards developing an accurate, location-based measure of DER value. They have decided the cost-benefit model to employ and are fostering the redesign of utility tariffs to establish new market based earnings (MBE) mechanisms for pricing to reflect equitable value, and optimize programs for energy efficiency, demand response, and renewable and storage deployment.

The eventual shift in balance from traditional regulatory incentives to MBEs opportunities will facilitate the transition to a business and regulatory model where utility profits are directly aligned with socially desirable market fulfillment activities that increase value to customers. System and societal costs can be reduced and, to some extent, borne by participants who benefit directly from the market, resulting in fewer costs that must be socialized among all ratepayers. This will promote both equity among customers and the incentive for utilities to encourage and facilitate the innovation in the market needed to implement DER.

3.1.3 Owner/Purchaser Relationship

The team evaluated several possible relationships that can be structured in relation to the ownership of the microgrid: (1) public entity ownership, (2) private ownership, and (3) public-private ownership. In

¹⁷ Each utility delivery component, wire, cable, circuit breaker, transformer, switchgear, connector has a technical limitation as to its ability to provide electric service. Additionally delivery asset elements (distribution feeder, substations) which are constructed of these components have their own operating criteria, which if exceeded will result in either asset element destruction or compromise leading to reduced quality or quantity of service. Public and personnel safety are overarching requirements of the net system performance expectation.

each approach, a special-purpose entity (SPE) could be structured to facilitate single or joint ownership while providing focused governance for the long-term operations of the microgrid.

The team believes that the most attractive option for the Near Westside is for the microgrid to be owned by a third party through a SPE. In this approach, the SPE will negotiate an individual power purchase agreements (PPA) with each customer that is served. These agreements will detail how much power will be provided in both normal operation and in island mode, and will indicate the type of energy generation equipment (solar, natural gas, etc). The exact nature of these agreements will depend on the design of the final system in Stage 2.

Throughout the NY Prize Stage 1 feasibility study, the project team has engaged major Syracuse Near Westside stakeholders and individual facility owners. Team members worked with stakeholders to determine which facilities are critical during an extended power outage, conducted site evaluations, and shared the preliminary conceptual microgrid design. This collaborative approach has helped to build interest, engagement, and a desire in the Syracuse Near Westside community to pursue a microgrid project.

3.1.4 Normal and Islanded Operations

Under normal operations, the microgrid will operate in a grid-connected mode, and the microgrid resources will provide approximately 85% of the total energy (kWh) needs of the facilities in each node. The microgrid resources will be managed to maximize the use of renewable energy resources and to maximize economic performance through optimized dispatch of systems and participation in utility programs. The microgrid nodes are sized to prevent an export to the grid. The neighborhood energy resource (NER) is sized to serve the local community to minimize required energy from the larger grid.

Island mode operation is the key to Syracuse Near Westside resiliency during a power system disturbance from major storms or other events, and it is necessary in both short- and long-term outages. The design of the Syracuse Near Westside microgrid incorporates semi-automatic operation so that a utility operator or local energy manager will be able to island intentionally. There is a defined sequence of operation that an operator will need to take before opening the point of common coupling (PCC) to create the island operation. The local microgrid controller will be responsible for determining the voltage source and load following resources for transitioning to an island mode.

The unique design of this microgrid will allow all facilities in the Syracuse Near Westside to be served by the microgrid during both normal and island operations.

3.1.5 Contractual Agreements

Assuming a third-party SPE, it is anticipated that the SPE will be created by the Hitachi Microgrid Solutions Business to build and operate the system, providing power purchase agreements (PPAs) to all customers in the system. There will not be considerable difference between the contracts with facilities identified as critical and those considered neighborhood Syracuse Near Westside loads, as the project team does not anticipate the need to cut off any facilities. In the event that system usage exceeds system capacity, the system would first utilize load modulation at facilities with building management systems. If that were insufficient, emergency generators currently in the system could be brought online. The mechanics of this process and how it will be reflected in the contracting documents, primarily PPAs, will be delineated in Stage 2 of this project – detailed design and contracting.

3.2. Commercial Viability – Value Proposition

The Syracuse Near Westside microgrid will deliver a range of benefits to residents, the community, the utility, and to the system owner.

3.2.1 Community Value

In order to understand the value of microgrid benefits for the Near Westside neighborhood, the project team used proprietary Hitachi software called EconoSCOPE™ to model project costs and benefits. This software utilizes outputs from Hitachi’s technical design models and provides details of potential project costs and revenue streams (including PPA rates) with greater resolution than any other tool the project team could identify in the U.S. The tool was designed and is supported by a development team at Hitachi’s Matsudo Research Center in Japan where Hitachi has developed and financed hundreds of renewables, distributed generation and microgrid projects.

The Syracuse Near Westside project will be able to provide energy resilience for the entire Syracuse Near Westside in the case of grid outage. In the case of local distribution line loss (within the neighborhood) energy resilience will still be achieved at each of the six nodes in the system design.

Table 3.2 – Overview of Microgrid Nodes

Microgrid Node #	Name	Facilities	Functions
1	Fire Station #6	<ul style="list-style-type: none"> • Fire Station 	<ul style="list-style-type: none"> • Public Safety
2	Syracuse Near Westside Partners	<ul style="list-style-type: none"> • Public Television Station • Community Center • Mixed-use buildings (Lincoln Supply, Delavan Center) • Architecture Firm • Industrial Building • Children’s Center 	<ul style="list-style-type: none"> • Economic Development • Community Support
3	Syracuse Housing Authority	<ul style="list-style-type: none"> • Housing Authority Residences • Primary Health Care Center • Pharmacy • Market • Family Center • Church • School 	<ul style="list-style-type: none"> • Vulnerable Resident Housing • Medical • Medicine • Food • Shelter • Community Support
4	Blodgett School	<ul style="list-style-type: none"> • School 	<ul style="list-style-type: none"> • Shelter
5	Rock West	<ul style="list-style-type: none"> • Police Dept. • Various Commercial 	<ul style="list-style-type: none"> • Public Safety • Economic Development
6	Fowler HS	<ul style="list-style-type: none"> • High School 	<ul style="list-style-type: none"> • Shelter

Based on the EconoSCOPE model, the proposed design will deliver 45,748,100 kilowatt hours of energy per year from on-site distributed energy resources. The system would cost roughly \$ 12,566,400 to

build, and have an unlevered internal rate of return of 6%. Total customer savings are estimated to be \$104,000 annually. The proposed system would also produce 2,398 fewer tons of greenhouse gases each year, due to an emissions profile that is much cleaner than that of the utility. These numbers are generated using the design proposed in Task 2 and assuming the system was financed using 25-year power purchase agreements (PPAs) to recoup the investment in the system.

The community value proposition includes lower costs for customers, and more reliable electric service. The resilience of the supply of electric is enhanced with smaller, local distributed resources. An important aspect of microgrid value to the customer is local control of power quality and the investment needed to provide tailored power quality solutions. The tradition in electricity supply has been one of universal standards for power quality under the utility obligation to serve model. While not necessarily achieved in practice, the reality for power quality and reliability has been to deliver the same standard (within acceptable ranges) in all parts of the supply network at all times. Achieving the target reliability performance has both physical and operational costs. Improving power quality and reliability require both investment in equipment and redundancy along with conservative operating procedures. DER creates an opportunity for tailoring local designed to meet the requirements of end-user and provide an economic benefit. Matching reliability and power quality requirements more precisely than is done today will yield considerable customer and community benefits.

3.2.2 Ownership Model

These outcomes are based on a model that employs an SPE to develop, operate, and maintain the microgrid system. Customers in the Syracuse Near Westside community would incur no up-front costs to build the project but would get all of the benefits of energy resilience during a grid outage while also reducing their energy costs.

The SPE will engage a design team to finalize the construction drawings and utility interconnection agreements. The SPE will engage an engineering, procurement, and construction firm to build the microgrid, and will be financially responsible for all engineering, procurement, and construction for the system. The SPE will also be financially responsible integrating the controls and communications systems. This process is presented in the Figure 3.2 below and was introduced in Section 1.2.1.

Figure 3.2: Microgrid Development Relationships

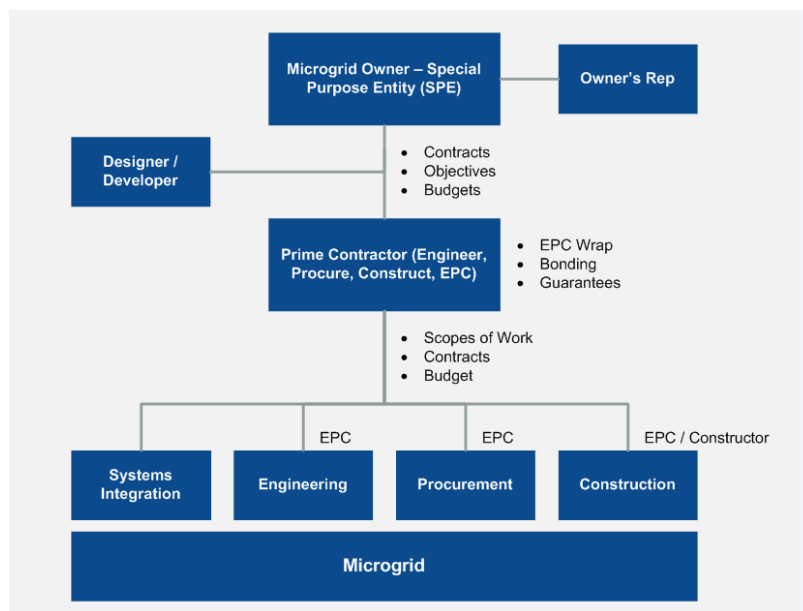

To ensure proper operation of individual microgrid resources, an energy performance contractor (selected through a partnership or solicitation, and hired by the SPE) will conduct site acceptance tests that validate the operation and performance of the new equipment. Once the system construction and integration are complete, the SPE will engage a third party commissioning agent that will test the microgrid as a system to ensure that the controls, communication, and sequence of operation function to meet the requirements as defined in the specified use cases and the final design. After the fully commissioned system is accepted and transferred to the SPE, the preliminary expectation is that the SPE will own and operate the microgrid for a period of 25 years. If this project is selected for further development in Stage 2 of NYPrize, the team would propose to evaluate how shorter PPA periods would affect the “per kWh” price and discuss those options with potential system participants.

3.2.3 SWOT Analysis

The third-party ownership approach offers customers in the Syracuse Near Westside community many advantages and few risks as the following SWOT analysis demonstrates. The specific terms of the PPA will affect (amplify or mitigate) the impacts of the various characteristics described below.

Strengths

- This model is associated with no or low up-front cost to the customers. The Special Purpose Entity (SPE) arranges all financing which enables resources secured by the Near Westside Initiative to be used for other needs and opportunities to continue to revitalize the Syracuse Near Westside community.
- The PPA establishes predictable energy prices for the customers at or below utility rates during the course of the PPA term – typically 25 years (limited allowances for fluctuations in rates are included for fuel pricing adjustments).
- The PPA secures the electricity output from the microgrid for critical Syracuse Near Westside facilities.
- The PPA clearly defines the annual energy delivered and the associated costs.
- A tax-exempt entity (e.g., local government, non-profit) can receive reduced electricity prices due to savings passed on from federal and state tax incentives available to the SPE.
- A third-party SPE can take advantage of the Federal Investment Tax Credits for qualified costs to essentially reduce the total project cost.
- The SPE, rather than the municipality, handles billing for each facility on the microgrid (lower overhead expense for Syracuse Near Westside).
- The SPE handles regular operation, maintenance, and equipment replacement.
- Additional DER can easily be added to the microgrid as energy requirements increase.

Weaknesses

- Savings from new, more cost-effective solutions that are integrated into the microgrid over the life of the PPA are captured by the SPE rather than the Syracuse Near Westside.
- At the end of the PPA term, the PPA must be renegotiated. Alternatively, the assets can be transferred to the facility owner(s). This can also occur before the end of the PPA termination period, subject to “fair market value” terms defined in the agreement.
- If the buyers’ demand for energy significantly decreases, the PPA requires the buyer to continue to purchase the guaranteed amount of kilowatt-hours energy at the price agreed upon on the PPA.
- Additional coordination is required for maintenance and replacement of facility infrastructure (e.g., roofs) for facilities housing microgrid components (e.g., PV panels).

Opportunities

- The Near Westside Initiative will have capital and operating expense resources available to pursue other Syracuse Near Westside resilience projects or other priorities.
- The customers will have an opportunity to integrate existing distributed generation resources into the microgrid (and receive fair market value for these assets), optimizing return on investment for these existing assets.
- The Syracuse Near Westside has a set of resources at specific critical facilities to include in a comprehensive emergency preparedness plan.

Threats

- Municipal ordinances, public utility rules and requirements, and state regulations may cause constraints, including:
 - Debt limitations in state and local codes and ordinances
 - Limits on contracting authority in city codes and state statutes
 - Budgeting, public purpose, and credit-lending issues
 - Limits on authority to grant site interests and buy electricity
- During the term of the PPA, the SPE could face difficulties and dissolve, requiring ownership change.
- The microgrid arrangement may trigger interconnection agreements and fees from electrical distribution utility.
- Regulatory changes may burden the PPA arrangement.
- Fuel cost fluctuations may cause price adjustments.

3.2.4 Utility and Stakeholder Value

For the local utility and its other customers not being served by the microgrid, it is important to note that the bulk of the benefit lies in avoiding investment under the traditional utility cost of service business model which relies on averaging costs of service by service classification and assigning the utilities costs of service to rate classes. All utility rate classes' assigned costs of system expansion benefit when utility cost is avoided by DER. DER can avoid incremental investment in distribution, transmission, and generation levels of the power system. To the extent that new markets for DER are fostered through regulatory reform like REV, value signals provided to the DER market and to customers will reflect both long-term avoided costs and real-time energy market. Pricing signals will supply the information and compensation necessary to support market response by DER providers.

Specific Benefits of the Near Westside Community Microgrid to National Grid

The Near Westside Community Microgrid will reduce the electrical load to be served by the Fayette Street and Ash Street substations and certain distribution feeders emanating from those substations. Fayette Street substation is an older, inner city substation with limited physical expansion potential. Ash Street substation is a relatively new substation; however the feeders that emanate from it would require incremental investment to serve additional load currently being served by the Fayette Street Substation. Avoiding expansion of facilities from the Fayette Street substation and serving a load from Ash Street substation has in the past been a tactical choice made by National Grid as the load in the Near Westside has evolved over time.¹⁸ The economic benefit to National Grid and its other customers of the Near Westside Community Microgrid will be to avoid or delay National Grid delivery facility

¹⁸ This is evidenced by the past decisions of National Grid Ash Street substation service such as the redeveloped site for WCNV.

expansion as load would have grown (as seen by the utility) in the absence of a local microgrid development.

Near Westside Economic Benefit Assessment

Under common rules of regulation, National Grid's revenue requirements are determined by summing the current operating costs (not including interest on debt), an allowance for depreciation, income taxes, real estate and other taxes, insurance, working capital provision, administrative and general expenses, operation and maintenance, and revenue taxes plus a fair return on the investment rate base which is typically included in the cost of capital. Income taxes paid are dependent on taxable income. Interest on debt is a deductible expense in computing taxable income. The income tax subject to taxation will depend on the interest paid on borrowed money, the debt/equity ratio, the fair return allowed, and the investment rate base.¹⁹

In the specific case of the Near Westside Community Microgrid, on a pure utility delivery system asset avoided cost basis, it is assumed by the project team that the development and expansion of the Fayette Street substation can be delayed from the year 2020 to the year 2030, or ten years. Assuming further that the cost of the substation rebuild is \$5.3 million in 2020 dollars, the forgoing regulatory ratemaking approach yields a 10 year nominal economic benefit to National Grid and its ratepayers of over \$11 million in economic benefit. This analysis does not include the broader benefits from the microgrid in terms of resilience, local public safety, reduction in environmental emissions.

3.2.5 State Policy Objectives

The Near Westside Community Microgrid will support a number of state policy objectives related to energy.

Renewable Portfolio Standards (RPS)

New York's Renewable Portfolio Standard (RPS) seeks to increase the proportion of renewable electricity used by retail customers. The project leverages 138 kW of existing solar PV generation and will implement an additional 600 kW of new PV generation.

Reforming the Energy Vision (REV)

REV focuses on accelerating reliable, resilient, and affordable electric service to assure continued economic growth and prosperity for New York. The New York PSC is aligning markets and the regulatory landscape with the overarching state policy objectives of giving all customers new opportunities for energy savings, local power generation, and enhanced reliability to provide safe, clean, and affordable electric service. The REV initiative will lead to regulatory changes that promote more efficient use of energy, deeper penetration of renewable energy resources such as wind and solar, wider deployment of "distributed" energy resources, such as micro grids, roof-top solar and other on-site power supplies, and storage. This project encompasses many of the features of REV. It includes multiple node microgrids, on site power supply including CHP, improvements in resiliency including burial of cabling, roof top solar, and storage. The project also presents novel approaches to utility delivery and will serve as a model for future energy service business models.

2015 State Energy Plan

The 2015 State Energy Plan calls for a 40% reduction in greenhouse gases from 1990 levels, a 50% increase in renewables generation, and increase in efficiency resulting in 23% reduction in energy consumption compared to 2012 levels. The proposed system would also produce 2,398 fewer tons of greenhouse gases each year, due to an emissions profile that is much cleaner than that of the utility. The system will include a 600 kW increase in generation of power from renewables. Combined with existing

¹⁹ Principles of Engineering Economy, Grant, Ireson & Leavenworth, 8th Ed., p. 465.

138 kW solar PV this represents a displacement of about 5.7% of the electric load from the grid. CHP heat recovery will result in the recovery of about 31 million kBTU that will supplant about 35% of the existing 88 million kBTU thermal load in the microgrid.

Five Cities Energy Plans

The Syracuse Five Cities Energy Plan includes initiatives to coordinate with National Grid to improve infrastructure within city rights-of-ways, support private efforts to establish district energy and microgrids, and to increase the amount of renewable energy generated within Syracuse. Syracuse committed to support and encourage renewables and energy efficiency such as solar PV and microgrid demonstration projects.

3.2.6 Reliability/Resiliency

The Near Westside community includes a significant at-risk population in an area of historic disinvestment that have no other place to shelter and many residents are living on low incomes, are disabled, and/or require significant long term medical care. A microgrid serving the Near Westside community prevents grid disruptions that can cause community impacts far faster than a similar disruption other communities in Syracuse that are more mobile and have resources to adapt to power outages. The area includes six critical facilities—three schools, a firehouse, a police station, and a primary care medical facility. In addition, the area includes a diverse mix of uniquely owned/controlled buildings that provide valuable community services to the neighborhood that, if they remained open, will stabilize the community in times of power outages. In addition to these facilities there are hundreds of households in the community that will benefit from power provided by the Neighborhood Energy Resource that will provide power to the Fayette Street Substation Feeders. More details on resiliency and reliability were presented in Section 1.1.11.

3.2.7 Unique Site Characteristics

The design for this project includes generation not just at the node level, but at the substation level, giving the system the ability to potentially island an entire neighborhood should the grid be lost above the substation supplying the neighborhood. It also demonstrates how, through a blend of nodal and substation-based support, a microgrid can provide multiple layers of energy resilience, addressing line loss both outside and inside the neighborhood.

The operation of the microgrid will leverage the autonomous functionality of the microgrid controller, and minimize the need for on site operators. The controller will operate the microgrid to maximize economic benefits, minimize emissions, and maximize reliability of service in the event of a fault on the grid. In addition, the microgrid controller will monitor the performance, operation and alarms of the distributed resources. In the event of an alarm, the SPE will be notified through the Network Operations Center (NOC), and dispatch a service technician that will be engaged through a service contract. The microgrid controller will also track the hours of operation of each microgrid resource, and will employ a predictive maintenance strategy to schedule maintenance before any failure occurs, and at a time that will have the least impact on the overall operation of the microgrid. As the microgrid develops a history of performance, trending and signature analyses will grow adding to the microgrid's ability to anticipate failures.

In developing this project, the team attempted to design a system that would meet the current and future resilience needs of the Syracuse Near Westside, while also being replicable enough to yield lessons learned for the rest of New York State and advance statewide objectives for resilience, sustainability and technological innovation.

The Syracuse Near Westside project is unique because its mission is about more than energy resilience – it is about Syracuse Near Westside social resilience and economic development. The project is centered on low-income residences in the James Geddes Housing Development of the Syracuse Housing Authority. This residential community is home to 269 vulnerable and/or disabled residents in the high-rise towers. This group’s vulnerability to power outages means that the presence of a microgrid will have a greater positive impact on their lives than it would on a more affluent community. A microgrid may also become an attractive feature to businesses considering locating in this neighborhood, yielding economic development to this distressed neighborhood.

The project team believes that the Syracuse microgrid will yield lessons that can be applied across New York State. Syracuse’s Near Westside neighborhood is similar to hundreds of communities throughout Upstate New York that sprang to life with the opening of the Erie Canal in 1825. Today, the neighborhood faces a variety of challenges that are common in post-industrial urban communities throughout the state, including aging infrastructure, vacant and dilapidated properties, a significant population of vulnerable elderly and/or disabled individuals, and a relatively large proportion of low-to-moderate income households.

The benefits of the Syracuse Near Westside Microgrid project, in terms of resiliency, public health and safety, and economic development could prove the value of such projects to similar communities across the state, and across the country. This project covers a truly heterogeneous blend of residential, education, light industrial, and commercial spaces. A project in this kind of mixed-use environment will have tremendous replicability.

The project is also quite scalable. The Near Westside neighborhood borders downtown Syracuse, making it attractive to new commercial and residential customers. There are also areas of manufacturing and light industrial facilities. The energy control and monitoring infrastructure that will be developed as part of the microgrid project could easily control additional nodes within the Syracuse Near Westside. The presence of a microgrid so close to other critical loads in the Syracuse Near Westside will make additional microgrids or nodes more feasible from both a technical and public acceptance perspective.

It is not anticipated that the development of the microgrid system will experience any additional revenue streams or costs. The SPE model will mean that the community will incur no costs to buy or operate the system outside of the PPA (contract). Benefits from state incentives and any participation in the utility ancillary services market would be retained by the SPE. Due to the low cost per kWh and utility demand peak reduction provided by microgrid, many customers in the Near Westside system would experience reduced energy costs. Other customers will receive energy at the rate they are getting now but with the additional benefits of resilience and cleaner energy. The system, as modeled, will save the community approximately \$104,000 per year in energy costs.

A successful Syracuse Near Westside microgrid will establish an engineering and economic platform that facilitates efficient ongoing development and investments in local energy assets, and provides incentives for outcomes consistent with the objectives for this project. These objectives include: improved local resilience, energy efficiency, environmental performance, and financial performance. Specifically, the proposed microgrid would establish a physical platform for various entities – including customers, third parties, and utility holding companies – to install, integrate, and operate future distributed generation, energy storage, and demand-side management systems, as well as an economic platform for dispatching resources and managing economic transactions among counterparties within the microgrid service area.

The Syracuse Near Westside microgrid project will seek to leverage turn-key combined heat, cooling, and power (CHCP) systems, as identified by the NYSERDA CHP Acceleration Program. Photovoltaic

systems will be obtained from commercial vendors. Fuel cells and microturbines will also be given consideration due to their low emissions profile. The complete set of the Syracuse Near Westside's financial, performance, and emissions objectives will drive the type of CHCP units selected. The planned microgrid will include both electrical and thermal energy storage. Battery energy storage systems will be distributed with CHCP and PV to provide voltage and frequency support, smoothing and time-of-day shifting of solar PV output, island mode transition support, VAR management, and black start capabilities.

3.3. Commercial Viability – Project Team

The project team has identified the following roles for all involved parties including local partners, contractors, and suppliers. When a specific party has been identified for a particular role, justification is given for their selection.

3.3.1 Applicant

The applicant and lead for the microgrid feasibility study project is Syracuse University. Within Syracuse University, the project is led by Syracuse Center of Excellence in Environmental and Energy Systems (SyracuseCoE). SyracuseCoE initiated the project in partnership with the Near Westside Initiative Inc. (NWSI), a 501(c)(3) non-profit organization established in 2007 to empower neighborhood residents and drive revitalization efforts. NWSI has an exemplary record in engaging community partners and residents in evaluating options for community development. SyracuseCoE has been deeply engaged in NWSI right from the start, including assisting dozens of renovation and new construction projects adopt energy-efficiency and green building solutions. The project team has also engaged the City of Syracuse throughout the course of the feasibility study, and the City and has expressed written support for the project to improve the resilience, reliability, and sustainability of energy supply in the Near Westside neighborhood.

SyracuseCoE's mission is to accelerate the commercialization of innovations in energy and environmental systems for built environments. It strategically targeted the Near Westside neighborhood for this feasibility study to strengthen its capabilities to support commercialization of promising emerging technologies relating to microgrids by leverage its prior efforts in the neighborhood. In addition, SyracuseCoE sought to frame the project as a case study of opportunities for microgrids to catalyze revitalization of distressed neighborhoods in post-industrial cities across the state.

Syracuse University is a private, coeducational, urban institution with an enrollment of slightly over 20,000 full-time students. There are approximately 1,100 full-time instructional faculty members across 11 academic schools and colleges. Syracuse University's assets totaled \$2.7 billion as of June 30, 2015.²⁰ Investments totaled \$1.2 billion. Liabilities totaled \$827 million. The university's long term debt represented 54% of total liabilities.

A project to evaluate the feasibility of a microgrid in a distressed urban neighborhood is consistent with Syracuse University's missions of education and research. In addition, this project is aligned with the mission of SyracuseCoE, which Syracuse University operates under contracts from state, federal, and private sponsors. Owning and operating a microgrid in an urban neighborhood that does not include University facilities is not consistent with the University's mission. Development and implementation of an innovative microgrid in a first-of-its-kind application is aligned with University and SyracuseCoE missions. SyracuseCoE intends to support efforts led by project partners and/or NWSI to pursue

²⁰ http://comptroller.syr.edu/comptroller/uploads/2015_Annual_Report.pdf

development and implementation of plans for the envisioned microgrid in Syracuse’s Near Westside neighborhood.

3.3.2 Project Leader

SyracuseCoE anticipates that the full-system design of a microgrid for Syracuse’s Near Westside neighborhood will be led by the Hitachi Microgrid Solutions Business. This group has extensive experience in microgrid design and operation, including leading the preliminary design effort for the feasibility study. Hitachi also has access to the capital, at a competitive rate, needed to finance the system and set up an SPE to operate the equipment and manage PPAs. The members of the Hitachi Microgrid Solutions Business have designed over 50 microgrids, overseen the construction of seven microgrids, and published a book on the topic titled *Energy Resilient Buildings and Communities: A Practical Guide*. The Hitachi Microgrid Solutions Business will also leverage its close partnership with other Hitachi Companies to support faster microgrid development and deployment. These include:

- Hitachi America, Ltd. – Established in 1959 and headquartered in Tarrytown, NY, Hitachi America, Ltd. is a major infrastructure and technology services company in North America with offerings in electronics, power and industrial equipment and services, and infrastructural systems throughout the Americas.
- Hitachi Capital Corporation – Established in 1969, Hitachi Capital provides financing to various Hitachi Group Companies and the commercial business sector worldwide. Hitachi Capital’s Energy Projects Division is one of its largest and fastest growing groups and it currently owns and finances projects through PPAs all over the world.

Together, this team has the financial strength to ensure that a community microgrid for Syracuse’s Near Westside neighborhood can be completed and sustained over time. Hitachi has more than 100 years of experience in product and service innovation and quality engineering. In 2012, the company had \$96.2 billion in revenue and spent \$3.7 billion on research and development. The company’s 326,240 employees are all directed toward advancing Social Innovation – the idea that Hitachi’s technological innovation should be leveraged for environmental and social good. This goal is directly supported by Hitachi’s expanding Microgrid Solutions Business. Hitachi Capital, the likely financier of the Syracuse Near Westside microgrid, has over 5,000 employees and has made investments exceeding \$17 billion to support Hitachi’s Social Innovation projects.

Hitachi’s expertise alone will not be enough to ensure project success. There are several critical roles that must be filled when designing a complex Syracuse Near Westside-wide microgrid.

Project Financiers

Hitachi Capital has indicated interest in serving as the lead shareholder in the SPE, and could arrange for the related project financing. Hitachi Capital has a division dedicated specifically to energy project finance, and has financed more than 200 renewable and DER projects at highly competitive rates.

Microgrid Control Provider

Effective control and optimization are critical features in any microgrid. To control the Syracuse Near Westside microgrid, the project team has identified the GreenBus® software interoperability platform from Green Energy Corp. This open source software system will allow for a remote network operations center to monitor every aspect of the energy system, detect failures, and perform continuous economic optimization of system parameters. When communications are down, the GreenBus software located on-site at each microgrid node will operate independently, optimizing performance to ensure continuous up-time of system resources.

Engineering Procurement Construction (EPC) Contractor

The EPC contractor will be responsible for detailed engineering drawings of the system, purchasing the equipment specified in the design, and overseeing construction and commissioning of the microgrid system itself. The project team has long-term and strong relationships with many EPC contractors and is in discussions with several regarding the Syracuse Near Westside microgrid project. A final selection will be made during the proposal process for Stage 2.

Combined Heat and Power (CHP) Design Firm

To ensure optimal design and placement of the generation and heat sources in the microgrid, the project team will leverage a firm that specializes in CHP applications. The project team is currently in discussions with multiple CHP design and installation firms to determine which one would be an ideal partner to execute the CHP portion of microgrid projects in the State of New York. The team will develop a competitive RFP process to identify and select the CHP firm with the most attractive combination of experience, skillsets, and price.

Photovoltaic System Design Firm

To ensure that photovoltaic (PV) generation systems in the microgrid are designed and placed for optimal performance, the project team will partner with a firm that specializes in PV applications. The project team is currently in discussions with multiple PV design firms to determine which one would be an ideal partner with execute the PV portion of microgrid projects in the State of New York. The team will develop a competitive RFP process to identify and select the PV firm with the most attractive combination of experience, skillsets, and price.

Operations and Maintenance Firm

Once a system is installed, operations and maintenance on the equipment will be critical to ensure both the resilience and profitability of the system. The SPE that owns the system will need to retain the services of an O&M firm with qualified team members close to Syracuse. The team will develop a competitive RFP process to identify and select the team with the most attractive combination of experience, skillsets, and price.

Legal and Regulatory Advisors

Hitachi's Microgrid Solutions Business is served by Crowell & Moring outside counsel. Crowell & Moring has a dedicated energy practice with more than 50 attorneys and a significant presence in New York. Further credentials can be provided on request.

As described in Section 1.c, a Special Purpose Entity could exist via public/private ownership. However, at this time, no Syracuse Near Westside customers or public stakeholders have expressed interest in an ownership role.

3.4. Commercial Viability – Creating and Delivering Value

In this feasibility study, the project team developed a microgrid system that will deliver maximum value to Near Westside customers in the areas of energy resilience, cost savings, and sustainability. Energy resilience is a leading motivation due to the at-risk nature of the local population. Tailoring a system to meet this priority requires careful selection of technologies and a tailored operational approach.

The selection of technologies happens in two stages. First, a portfolio of resources is defined based on the needs of the microgrid node or the microgrid as a whole. Then each piece of equipment within that portfolio is specified and sized.

3.4.1 Portfolio Approach

As described earlier in this report, the project team used a *Microgrid Portfolio Approach* to select distributed energy resources for the microgrid. This approach focuses on analysis of the energy requirements of covered facilities, and is intended to achieve a close match between the DER portfolio and the electric load profile of those facilities. Instead of sizing the DER portfolio to match the sum of the peak loads at each critical facility in the microgrid, the portfolio approach allows DER to be sized to meet the loads of these facilities almost all the time, without over-building. The benefit of this approach is to enable the microgrid resources to serve the microgrid loads more efficiently, more cost effectively, and with lower emissions per unit of energy consumed.

From a long-term operations and maintenance standpoint, the Portfolio Approach enables the microgrid to operate energy resources within their design envelope. This keeps maintenance costs and fuel costs at a minimum, and helps to lower the total cost of ownership. This design approach also incorporates active microgrid controls that enable optimal operation of energy storage, PV, and building management systems to manage load and reduce the afternoon peak load when needed.

In another element of our strategy for resource selection and sizing, when operating in a grid-connected mode, the microgrid uses the grid as a resource to meet intermittent peak demand periods. When operating in island mode, the microgrid supply and demand will be managed through dispatching microgrid generation, load management, and minimal use of existing backup generation. This methodology allows the designers to evaluate the appropriate balance of grid service, generation resources, and load management capabilities, and provide both a technical and economic solution.

It is important to ensure that the PPA / ESA structure and performance standards are consistent with and supportive of the microgrid resource portfolio approach. For example, economic savings and emissions reduction are based on the long-term balancing of resources within the portfolio. Too much manual control over dispatch may allow operation outside of the optimized parameters, and can lead to reduced savings, decreased reliability, increased emissions, and shortened equipment lifespans.

3.4.2 Technology Specification

As the DER portfolio is structured, the project team will determine the size, manner of use, and specifications of each piece of DER equipment, and identify a vendor to provide the equipment. The project team made some of these decisions (resource type, sizing, operation, and location) as part of the feasibility study, and reported these decisions in Task 2. Other decisions (such as specifications and vendor) will be made in the detailed design phase of the project (Stage 2).

The project team will give preference to the most mature technologies available for each purpose that meet or exceed the stakeholder and design objectives. Where the project must use emerging technology (namely microgrid controls and energy storage), the project team will take special measures to prove each product before including it in the microgrid. These measures will include detailed and thorough testing and commissioning, and securing strong vendor warranties that include an obligation to quickly fix any issues that may arise.

The following criteria have been used by the project team to make design decisions around microgrid technologies.

Combined Heat and Power and Natural Gas Engines

Selection Factors: The project team will look for the equipment that meets the following criteria:

- High overall performance
- High intensity (hours per year) performance
- Low \$/MWh

- Low emissions/MWh
- Proven continuous duty
- Low capital cost (\$/kW installed)
- Low O&M cost (\$/kWh)
- Readily available troubleshooting and maintenance service
- Manufacturer reputation

Benefits: Fulfills the need for base generation in the microgrid resource portfolio approach. CHP applications provide extremely high thermal efficiencies.

Challenges: Typically fueled with fossil energy, fuel costs, maintenance costs, and overhaul costs.

Design Considerations:

- Fuel Supply
- Available Space
- Siting
- Heat Recovery Opportunities
- Load Following Operations
- Maintenance Requirements

Current Resources to be Leveraged: None

Photovoltaics

Selection Factors: The project team will look for the equipment that meets the following criteria:

- Hail rated
- Low annual degradation < 0.5%/yr
- High watts per panel
- Capital cost (\$/kW installed)
- Low maintenance
- Manufacturer production capacity
- Manufacturer history
- Manufacturer reputation

Benefit: Generation profile generally aligns with the load profile, which is energy efficient; very low O&M, zero fuel cost.

Challenges: Low overall capacity factor for the installed cost.

Design Considerations:

- Available Space
- Installation Locations
- Shading Issues
- Intermittency
- Maintenance Requirements
- Resiliency to wind and snow

Current Resources to be Leveraged: The Syracuse Near Westside currently has three existing PV installation. The SPE will incorporate this system into the operational microgrid so that they can continue to generate energy for their host facilities if and when the system is operating in island mode.

Table 3.3: Existing PV Resources

Location	PV Capacity
King & King Architects	12 kW
WCNY	95 kW
Lincoln Supply	31 kW

Energy Storage System (ESS)

Selection Factors: The project team will look for the equipment that meets the following criteria:

- Compatible sizes and performance to our needs
- Low annual degradation
- Short-term super capacity
- High AC – AC round trip efficiency
- History in the field beyond the laboratory, and
- Manufacturer reputation.

Benefits: Provides many functions in one efficiently operating unit (PV smoothing, peak shifting, VAR management, frequency support, voltage support, black start, mode transition management, etc)

Challenges: High installed capital cost, risk of shortened life from mismanagement.

Design Considerations:

- Selection
 - Technology
 - Battery System
 - Power Conversion System (PCS)
 - Integration
- Sizing
- Siting
- Modes of Operation
- Control Optimization

Current Resources to be Leveraged: None

Microgrid Controls

Selection Factors: The project team will look for the equipment that meets the following features and criteria:

- Multi-objective optimization
- Real-time operational background
- Ability to actively communicate with devices and resources in real-time
- Manufacturer reputation / likelihood of being around for more than 5 years

Benefits: Active microgrid controls provide economic optimization, reliability optimization, resiliency optimization, and emissions optimization, provides a data rich environment for trending, signature analysis, and sharing with stakeholders.

Challenges: Immature technology with few quality vendors holding solid track records. Many traditional vendors are offering programmed logic controls, which cannot provide the optimization functions expected of microgrid controls.

Design Considerations:

- Platform
- Vendor Experience
- Architecture
- Control Approach
- Optimization
- Communications
- Cyber Security

Current Resources to be Leveraged: None

Point of Common Coupling (PCC)

Selection Factors: High quality switches and breakers, long lifetime performance, and manufacturer reputation.

Benefits: Simplifies the interconnection between the microgrid and the distribution utility, affords a data rich environment for the system owner and the utility as this important electrical junction.

Challenges: High installed capital cost.

Design Considerations:

- Communication protocol
- Synchronizing capabilities

Current Resources to be Leveraged: None

Backup Generators

The design does not include the installation of new backup generators. In cases where there are not backup generators, the microgrid design uses CHP, PV, energy storage and building load control to operate the entire facility or the specified critical load during an outage. In cases where there are existing backup generators, they are included in the resource mix but operated within their onsite fuel capacity during a one week outage. The operation is support by the other microgrid resources which offset the need for the backup generators except at times of high electric demand.

Current Resources to be Leveraged: The Syracuse Near Westside currently has multiple backup generator installations. These systems do not need to be incorporated into the microgrid system as they are already wired to serve the facilities where they are located. For economic reasons, the 650 kW generator at WCNY was not included in the microgrid design to be utilized during an outage in islanded mode.

Table 3.4: Existing Emergency Generation

Location	Capacity (kW)	Fuel Type
Fowler High School	2 x 75 W	Diesel
James Geddes Housing Development	38 kW	Natural Gas
James Geddes Housing Development	30 kW	Natural Gas
WCNY	650 kW	Natural Gas

3.4.3 Development, Construction and Operating Approach

Once the design phase of a microgrid project is complete, the project must be brought to life by a well-designed and effectively supported development approach. The Hitachi Microgrid Lifecycle process closely matches the NY Prize process shown in Figure 5:

Figure 3.3: Hitachi Microgrid Lifecycle

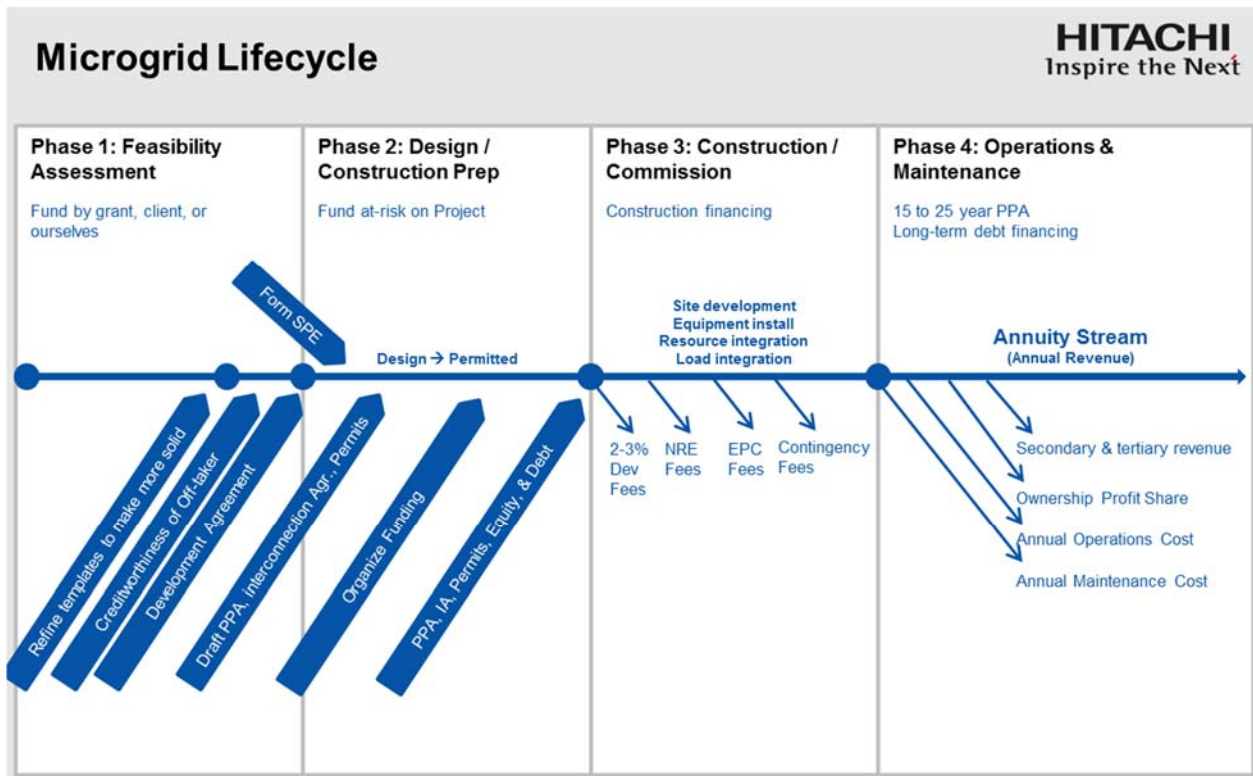

In addition to the elements included in NY Prize Stage 1, the Hitachi Microgrid Lifecycle includes an evaluation of the off-taker creditworthiness.

In addition to the elements included in NY Prize Stage 2, the Hitachi Microgrid Lifecycle includes establishing a special purpose entity (SPE) early in the process to formulate the business model negotiation (see Section also 1.2.1).

Prior to construction, it is important to clearly define the manner in which operations and maintenance (O&M) will be managed once the microgrid is operational. There are multiple options for handling microgrid O&M:

- System owner O&M – the system owner, or SPE, hires staff to operate and maintain the microgrid.
- O&M Contractor – the SPE hires an O&M contractor under a long term service-level agreement.
- Separate Operations and Maintenance Contractors – the SPE hires separate operations and maintenance contractors under long term service-level agreements because each has its own skills advantages and cost savings advantages.

For the long term benefit of all stakeholders, it is important to structure a deal where all parties benefit from optimal operations of the microgrid. Therefore, the SPE revenue and profitability must be in balance with savings to the Syracuse Near Westside off-takers for all stakeholders to be motivated over

the long-term. The appropriate O&M approach for the Syracuse Near Westside microgrid has not yet been determined.

System development will involve a complex permitting process. In Stage 2 design development, the team will conduct an environmental assessment that includes CHP air emissions, PV and ESS recycle potential, inverter recycle potential, and visual pollution. The CHP systems will require air quality operating permits, but all proposed systems will qualify for permitting.

The local utility will need to approve of the design of the switching that provides disconnect, islanding, and restoration functions in case of power disruption. The utility will also need to approve any plans to use of sections of utility distribution equipment while in island mode.

The utility will coordinate protection and switching schemes for the PCC and the distribution system. The project team will address these needs in the interconnection agreement (IA) and the studies that support it. The PCC approach simplifies the IA and studies for the utility. This is due to the straight-forward approach taken to isolate the microgrid from the distribution grid with control by the utility in accordance with the IEEE 1547 interconnection standard. This gives the utility more control and makes the IA easier to approve.

The project team intends to use underground cabling to connect loads within nodes in the Syracuse Near Westside microgrid. The rationale for this approach is that overhead distribution lines do not provide the resiliency or reliability required to meet the intended uptime requirements. Ownership of new purchased and installed underground cabling could be retained by the SPE or gifted to the utility, based on the objectives of Syracuse Near Westside stakeholders. The REV proceedings include a consideration of such arrangements. An alternate arrangement could be for the utility to own the underground cable. However, this approach is likely to add delivery charges, which, if based on past practice and not true value, may eliminate nearly all the Syracuse Near Westside's financial benefit to have the microgrid.

Operation of the microgrid will include several key components:

Metering: The SPE will require the state of New York to allow sub-metering that can be applied to the microgrid. The project team will add new sub-metering as necessary.

Technical Operations: The microgrid controls, and microgrid design, are based on the ten ORNL Microgrid Use Cases. The most important use cases address transition to an island mode (planned and unplanned) and return to grid-connected operations. If desired, the project team can provide a very detailed Sequence of Operations for transitioning to island and back to grid-connected mode.

Under normal conditions, the microgrid will operate under one of two regimes to accommodate its nodal structure. The first regime is local (within each node) where optimization is primarily focused on assurance of reliable and resilient operations. The second regime is global – across the entire microgrid – where optimization includes economic and emissions reduction objectives. At the global microgrid level, operations are focused on savings to the Syracuse Near Westside and reduction of emissions.

Financial Operations: The SPE will bill microgrid customers monthly for energy used by system resources. The project team's approach to the PPA simplifies this process, billing consumed \$/kWh monthly instead of the 18+ billing determinants in a typical utility electric bill. Depending on how the SPE is established with the Syracuse Near Westside, the customer may still be billed by the utility. To simplify bill management for the customers of the microgrid, the utility bill may become a pass-through within the microgrid billing.

Transactional: Any additional revenue to customers from shared utility program participation (DR, ancillary services) will be accounted for in the monthly bill that the customer receives from the SPE.

3.4.4 Market Barriers

As discussed in the introduction, there are a number of variables which could impact the viability of the project, even if the technical and economic fundamentals look strong. They include:

Financing: There may be aspects of the current market that make securing financing at a competitive cost of capital more difficult. The primary barrier is the education level and familiarity with microgrids within the finance sector. While solar PPAs are now a well-established financing opportunity, ten years ago this was not the case. Today, microgrids are not as well understood by the financial sector. The financial industry has not yet created standardized financing products for microgrids, making each new product a custom deal. This tends to drive up the cost of capital. Hitachi Capital and its partners understand Hitachi's Microgrid Solutions Business and the market, and the project team is therefore optimistic that this barrier will be reduced.

Customer Commitments: The project economics are highly sensitive to the microgrid design, and the design is dependent on customer sites and loads, and the DER planned for those locations. A major risk is posed by the possibility of customers withdrawing before final contracts are signed. This would affect the overall microgrid design and fundamental project economics.

Utility Cooperation: The negotiation of interconnection agreements with local utilities can cause significant delays and lead to new costs. Challenges can arise when proposed microgrid concepts are unfamiliar to the utility's staff and engineering contractors. During the feasibility study, the project team had positive initial discussions with National Grid engineers, who expressed interest in the proposed nodal approach. Based on these initial discussions the team expects this risks of challenges with coordination with the local utility to be low to moderate in the next phase.

3.5. Financial Viability

The project team conducted a thorough econometric analysis of the proposed Syracuse Near Westside microgrid to determine the financial viability of the project. Hitachi has developed proprietary economic modelling software, known as EconoSCOPE™, that is specifically designed to support financial analysis for public infrastructure projects. The project team used this software to support the analysis of the financial viability of the Syracuse Near Westside microgrid project, and found that the financial case for this project is strong. Its unlevered IRR of 6% will make it attractive to the financial community. The ability to deliver an energy-resilient, more-sustainable energy system at or below current system rates will make it attractive to potential customers in the neighborhood. This project will save money for the people of the Near Westside while making money for the owners of the SPE.

Many factors impact the financial viability and profitability of a microgrid project. Some of these include:

- The age, size, and condition of existing assets
- The cost and performance of the new system and its components
- The control technologies
- Potential for energy efficiency improvements
- Tax and other incentives
- The cost and time associated with interconnection agreements
- Potential for Demand Response
- Potential for market participation (through CCA and other means)

The project team evaluated all available financial incentives into account when performing the financial analysis for the Syracuse Near Westside microgrid. However, the revenues and costs described in this section do not rely on third party incentives, assumptions about market participation, demand response capability, or other factors related to system economics. Financial institutions do not yet allow for recognition of such factors in their evaluations of project attractiveness. Therefore, Hitachi does not include them in the underlying economic analysis at this time. The financial incentives that the project team has assessed include the following programs:

- **Demand Response:** National Grid’s demand response programs pay customers who are able to temporarily reduce electric usage when requested. This capability will be improved by the existence of the microgrid.
- **NYSERDA PON 2568 CHP Acceleration Program:** This program provides financial incentives for the installation CHP systems at customer sites that pay the SBC surcharge on their electric bill.
- **NY SUN initiative:** This program provides rebates and performance incentives for new residential and commercial solar PV installations.
- **Sales Tax Exemption:** Solar photovoltaic systems are 100% free from state and local taxes.
- **Business Energy Investment Tax Credit (ITC):** The ITC includes a 30% tax credit for solar or fuel cell systems on residential and commercial properties, and 10% tax credit for CHP systems.
- **New York Power Authority – Energy Services Program for Public Utilities:** Provides various rebates on energy efficient equipment.
- **Federal Energy-Efficient Commercial Buildings Tax Deduction:** \$0.30-\$1.80 per square foot, depending on technology and amount of energy reduction for buildings that become certified as meeting specific energy reduction targets as a result of improvements in interior lighting; building envelope; or heating, cooling, ventilation, or hot water systems.

Leveraging these and any other programs that exist but were not identified in this project will contribute to the financial success of the system beyond what Hitachi has modeled in EconoSCOPE.

While the Near Westside Microgrid project is strong, it would be financially tenuous to develop without additional incentives that may be obtained through the NY Prize project. Additional NYSERDA funding will almost certainly be needed to make the project financially competitive.

3.6. Legal Viability

3.6.1 Ownership Structure

The project team has developed a model for the legal organization of the Syracuse Near Westside microgrid based on ownership by a dedicated SPE. The project team has proven the legal viability of this model through numerous existing microgrid projects. This ownership structure maximizes opportunity for low-cost financing, and helps to ensure that final customer rates are kept as low as possible.

In addition to the SPE additional team members or Syracuse Near Westside stakeholders may decide to take an ownership stake in the system. However, at this time, no Syracuse Near Westside customers or stakeholders have expressed interest in an ownership role. As the lead developer of the Stage 1 feasibility study, Hitachi is in a unique position to understand the value of the Syracuse microgrid and how to make the project a success.

The SPE will not own the real estate or facilities in which microgrid systems and equipment will be installed. In each case these sites are owned by customers included in the microgrid. These customers have been included in the planning process during the feasibility study. Representatives for each evaluated facility accompanied the project team as they walked through the sites, they have worked

with the project team to gather data necessary to construct the model, and they will be invited to the project close out meeting. In each step of the process the project team has discussed plans for siting microgrid equipment at each site with the customers who own that site, and have received their provisional approval.

3.6.2 Ownership and Public Service Law Regulatory Treatment

The important legal question will be whether the microgrid is an electric distribution company under Public Service Law, and if so, what level of regulation it will fall under at the Public Service Commission (PSC). Discussion of the State-level regulatory landscape, Section 2 of the Public Service Law, and various cases applying its standards will inform this discussion. New models of regulatory treatment, currently under discussion in the REV proceeding, may also apply if adopted in the future.

Currently Existing Regimes of Regulating Privately-Owned Microgrid Distribution Under Public Service Law

Under existing law and PSC guidance, the Syracuse microgrid will be treated as an electric corporation under Public Service Law unless it is deemed a qualifying facility under the terms of PSL §§ 2(2-d) or otherwise qualifies for lightened regulation.

If subject to the full spectrum of regulation that the PSC may exercise over an electric corporation, the microgrid may be regulated for general supervision²¹ (investigating the manufacture, distribution, and transmission of electricity; ordering improvements; and performing audits), rates,²² safe and adequate service,²³ all aspects of the billing process, financial, record-keeping, and accounting requirements,²⁴ corporate finance and structure,²⁵ and more. This expansive purview of regulation may prove too administratively onerous for a small project like the Near Westside microgrid to comply with. It is therefore important that, if the microgrid utilizes private distribution infrastructure, it be designated a qualifying facility, be subject to lightened regulation, or be granted some alternate regulatory status, as discussed in part (B) of this section.

Qualifying Facility

The Near Westside microgrid may be exempted from much of the PSL regulation applying to electric distribution companies if it is deemed a qualifying facility under the terms of PSL §2. A microgrid will be deemed a qualifying facility if it utilizes qualifying forms of generation,²⁶ is under 80 MW,²⁷ serves a

²¹ PSL § 66.

²² PSL § 65.

²³ PSL § 66.

²⁴ PSL § 66, 68(a).

²⁵ PSL § 69.

²⁶ Qualifying generation facilities are defined in PSL § 2 as those falling under the definitions of “Co-generation facilities,” “Small hydro facilities,” or “Alternate energy production facilities.” A qualifying co-generation facility is defined as “Any facility with an electric generating capacity of up to eighty megawatts.... together with any related facilities located at the same project site, which is fueled by coal, gas, wood, alcohol, solid waste refuse-derived fuel, water or oil, and which simultaneously or sequentially produces either electricity or shaft horsepower and useful thermal energy that is used solely for industrial and/or commercial purposes.” NY PSL § 2-a. A qualifying small hydro facility is defined as “Any hydroelectric facility, together with any related facilities located at the same project site, with an electric generating capacity of up to eighty megawatts.” NY PSL § 2-c. A qualifying “alternate energy production facility is defined as “Any solar, wind turbine, fuel cell, tidal, wave energy, waste management resource recovery, refuse-derived fuel or wood burning facility, together with any related facilities located at the same project site, with an electric generating capacity of up to eighty megawatts, which produces electricity, gas or useful thermal energy.” NY PSL Ser § 2-b.

²⁷ Id.

qualifying number of users, and its related facilities (including any private distribution infrastructure) are located “at or near” its generating facilities.

In the proposed project, PV generation facilities have been proposed that will qualify. CHP facilities have also been proposed that will likely qualify if the electricity, shaft horsepower, or useful thermal energy is used solely for industrial and/or commercial purposes. Generation facilities less than the statutorily imposed 80 MW limit qualify.

It is difficult to apply the requirement that a microgrid serve a qualifying number of users in the abstract. This requirement has not been explicitly spoken to by the PSC, but has been contested in Case 07-E-0802, regarding the Burrstone Energy Center.²⁸ There, petitioners raised the question of whether a qualifying facility may distribute power to three different institutional users – a hospital, college, and nursing home. The PSC found that “furnishing electric service to multiple users” is specifically contemplated in PSL §2(2-d) “by providing that electricity may be distributed to ‘users,’ in the plural.”²⁹ The Burrstone Energy Project was held to qualify for regulatory exemption.

The *Burrstone* case is the only existing precedent of the PSC applying the “qualifying facility” standard to more than one user. One interpretation of this precedent might conclude that no upper bound exists on the number of users that may be served by a qualifying facility. This interpretation, however, may prove unwisely speculative. In the case of the Near Westside microgrid, it would be wise, as the petitioners in *Burrstone* did, to petition the PSC for a declaratory ruling that the multiple users anticipated in this microgrid do not run counter to the PSC’s interpretation of PSL §2.

Distribution facilities at or near generation: The physical distance that distribution facilities may extend from generation facilities has been questioned in several PSC decisions applying the qualifying facility standard.³⁰ A limited review of prior cases interpreting the “at or near” requirement could suggest that a project will be deemed a qualifying facility if its distribution network is under two miles. However, this range might expand (or contract) depending on several types of variables, which the PSC has cited in previous precedent, including: whether the project site is in a densely or sparsely developed location; what type of technologies it uses (e.g., a wind farm will naturally require a broader distribution network due to the acreage it takes up); and whether those facilities stay on private property or cross public rights of way.³¹

In the Near Westside microgrid project, the geographic footprint of private distribution facilities may satisfy the “at or near” test developed by the PSC. The maximum distance between properties proposed to be incorporated in the microgrid is approximately one mile. Private distribution facilities would have to cross property lines, and several rights of way. Declaratory rulings addressing facilities in comparable environments have met or exceeded this distance, such as *Burrstone* (approximately half a mile),³² *Nissoquogue Cogen Partners* (1.5 miles),³³ and *Nassau District Energy Corporation* (1.7 miles).³⁴ Of these, the closest precedent may be the *Burrstone* case, because the PSC in *Burrstone* considered whether crossing multiple property lines complicated the “at or near” analysis (while *Nissoquogue* and *NDEC*

²⁸ Case 07-E-0802 - Burrstone Energy Center LLC – Petition For a Declaratory Ruling That the Owner and Operator of a Proposed Cogeneration Facility Will Not Be Subject to Commission Jurisdiction (August 28, 2007).

²⁹ *Id.*

³⁰ See NYSEDA, “Microgrids for Critical Infrastructure Resiliency in New York,” (Dec. 2014), at 31.

³¹ *Id.*

³² Case 07-E-0802 - Burrstone Energy Center LLC – Petition For a Declaratory Ruling That the Owner and Operator of a Proposed Cogeneration Facility Will Not Be Subject to Commission Jurisdiction (August 28, 2007).

³³ Case 93-M-0564, *In re Nissoquogue Cogen Partners*, Declaratory Ruling (1993)

³⁴ Case 89-E-148, *Nassau District Energy Association*, Petition for a Declaratory Ruling (Sept. 27, 1989).

involved distribution passing almost entirely over a single property). If private distribution across the entire microgrid were proposed, it would likely mirror the length for which the PSC has provided positive precedent.

In light of the above factors, the microgrid is likely to satisfy the “at or near” requirement to achieve qualifying facility status, however the project team must petition the PSC for a declaratory ruling to this effect.

Lightened Regulation

If the project does not otherwise qualify for regulatory exemption, the project team may petition the PSC for a lightened regulatory burden. The PSC may consider a “realistic appraisal” of the need to regulate the microgrid based on a three-prong analysis: 1) whether a particular section of the PSL is inapplicable on its face; 2) if a provision is facially applicable, whether it is possible for an entity to comply with its requirements; and 3) whether imposing the requirements on an entity is necessary to protect the public interest, or whether doing so would adversely affect the public interest.³⁵ A realistic appraisal yields different results depending upon the microgrid’s characteristics. The PSC recently applied the “realistic appraisal” test to the Eastman Park facility, which resembles a microgrid.³⁶ The precedent of microgrids receiving lightened regulatory burden under this standard is very thin, however, and it is difficult to prognosticate how this standard would be applied to the Syracuse project.

Future Regimes of Regulating Privately-Owned Microgrid Distribution Under Public Service Law

In its 2015 “Order Adopting Regulatory Framework and Implementation Plan,”³⁷ the PSC considered that a third model for regulating “community microgrids” with respect to the PSL might be appropriate. The PSC did not fully articulate how this model would function or make specific proposals. Parties were invited to comment on this matter on May 1st, 2015. The Near Westside microgrid project may be impacted by any future regulatory developments issued by the PSC pursuant to these comments or otherwise in REV.

3.6.3 Contractual Considerations for Various Ownership Models

The regulatory implications addressed above make some distinction regarding who owns various types of microgrid infrastructure. As previously discussed, whether the utility or private parties own different types of microgrid assets may impact how they are treated by the PSC and under Public Service Law. However, setting aside State regulatory issues, there remain various contractual considerations that may impact how rights and responsibilities are aligned between microgrid parties.

Contracting between Utility and Customer/Project Developer in a Privately-Owned DER/Generation Model

There does not presently exist a model tariff for utilities to provide islanding service to a group of customers served by privately-owned DERs. However, different microgrids have proposed to move forward under existing or novel tariffs with the incumbent utility to use utility distribution and rely on the utility to integrate with private microgrid controllers to support islanding functionality.³⁸

³⁵ Case 98-E-1670, *In re Carr St. generating Station*, Order Providing for Lightened Regulation, at 4–5 (Apr. 23, 1999).

³⁶ Case 13-M-0028, *RED-Rochester LLC and Eastman Kodak Company*, Order Approving Transfer Subject to Conditions, Providing For Lightened Ratemaking Regulation, and Making Other Findings (issued May 30, 2013).

³⁷ Case 14-M-0101, Order Adopting Regulatory Framework and Implementation Plan, Feb. 26, 2015, at 110.

³⁸ See, e.g., discussion of the Parkville microgrid in NYSEERDA’s 2014 report, “Microgrids for Critical Infrastructure Resiliency in New York State,” at 129, which states that “The Parkville Microgrid will also employ a buy/sell

In the Near Westside project, existing utility distribution infrastructure may be employed, where the project exports power under a community net metering tariff, a combination of standard net metering and buyback tariffs, or any novel microgrid tariff proposed and approved for REV demonstration purposes. In this case, key considerations would include:

- Applicable tariff under which different levels of power export will occur
 - Any novel “microgrid wheeling charge” framework that compensates the utility for delivering power from one microgrid customer to the next and islanding the project during an outage.
- Rights of utility to access or control equipment and facilities to ensure operational safety (easements, fee for access, etc.)

Contracting between Customer and Private Developer

Privately-owned microgrids are permissible in New York, subject to the regulatory concerns around PSL regulation discussed in the previous section. See the Burrstone Energy Center case study in NYSERDA’s 2010 microgrid report.³⁹ A privately developed microgrid may be owned by a third-party developer with no pre-existing contractual relationship with the parties, or microgrid customers may collectively form a limited liability corporation for the purpose of owning and operating the microgrid on its customers’ behalf. In either case, contractual concerns for customers may include:

- Price of power
 - Potentially variable depending on demand, time of use
 - Potentially variable as linked to fluctuating operating costs, such as fuel prices
 - Value of tax credits, incentives, accelerated depreciation incorporated into rates or otherwise passed onto customers
- Customer obligation to take specific quantities of power or total system output over a given period
- Developer’s obligation to produce certain quantities of power over a given period
- Load shedding protocols
 - Price for varying levels of continued service in outage situation
- Penalties for non-performance or lateness in developing the project
- Ownership of RECs generated
- Any applicable terms relating to leasing customer land or facilities to microgrid owner
 - Insurance to cover damages to property
- Fair exit fees
- Allocation of interconnection costs
- Transferring obligation to future property owners / encumbering property
- Potential joint-financing schemes (i.e., a municipal customer with a higher credit rating than developer may take lead on securing financing for some portion of project)
- Privacy of customer usage data
- Division of operational responsibilities
- Allocation of potential liabilities / indemnification of customers or developer

arrangement for the hybrid utility microgrid in addition to utilizing virtual net metering. The net excess energy produced by the reciprocating engine in the school that is not credited to another municipal account via virtual net metering will be purchased by the utility at applicable buy-back rates. The other microgrid users (i.e., the supermarket and gas station) will continue to buy their energy from the utility at their normal tariffs.”

³⁹ NYSERDA, “Microgrids: An Assessment of the Value, Opportunities, and Barriers to Deployment in New York State,” (Sept. 2010) at A-45.

- Access rights to equipment/facilities (easements, fee for access, etc.)
- Purchase option at end of service term
- Division of interconnection costs between developer and customers

3.6.4 Franchises and Rights-Of-Way

All entities that require the use of public ways (i.e., for transmission or distribution facilities) must be granted permission by the presiding municipal authority in the form of a franchise or some lesser consent, depending on the scope of the usage. The cities, towns, and villages of New York have specific statutory authority to grant franchises: as provided by N.Y. Gen. City Law § 20(10), every city is empowered to grant franchises or rights to use the streets, waters, waterfront, public ways, and public places of the city.⁴⁰ “Use” encompasses occupying public rights-of-way and operation of the provider’s built infrastructure to provide the public service.⁴¹

In the city of Syracuse, the process for granting a franchise for electric distribution is controlled by Section 6-203 of the City Code, which states that:

- (1) Franchises may be granted pursuant to ordinance of council.
- (2) Franchises shall be granted to the highest bidder at public auction thereof.
- (3) No grant of a franchise shall be effective until the mayor approves the award thereof.
- (4) The council may grant, subject to the approval of the mayor, to the owner or lessees of any existing franchise, under which operations are actually being carried on, such additional rights or extensions in the streets in which the said franchise exists, upon such terms as the interests of the city may require.
- (5) No franchise shall be granted for a period of more than fifty (50) years.⁴²

The Syracuse City Code does not specify application procedures for the grant of a franchise, although Section 4-103 of City Code specifies the process by which City Council members may propose and adopt ordinances. It would appear that to obtain a franchise in the City of Syracuse, the microgrid owner would have to approach members of the Syracuse Council to propose an ordinance on their behalf, which ordinance must provide for the requested franchise to be offered at auction, before being approved by the mayor. The public auction requirement is unusual among common franchising provisions, and public auction provisions specific to franchises are not elsewhere specified in City Code. Further discussion with Counsel for the City of Syracuse may be necessary to determine the extent to which the public auction requirement would open bidding to competing energy services providers. A strong public interest rests in allowing a single project team to both manage the deployment of microgrid DERs and franchised distribution infrastructure. Coordinating with the City to conduct a controlled auction process that does not permit disruptive bids from entities unaffiliated with the project will be essential.

Applicable Tariffs

Distributed generation may be eligible for new tariffs for each of the customers at which DG is sited. This section outlines the various tariff structures one or several customers within the microgrid may fall under. This section builds on the discussion in Section I(2), which discussed tariffs under which power could be exported onto the utility grid, including net metering, buyback, offset, and potential future microgrid regimes.

⁴⁰ N.Y. Gen. City Law § 20(10). (NYJUR Franchise s 4)

⁴¹ See, e.g., “Contract of April 7, 1887 between Hess et al. Commissioners & Consolidated Telegraph & Electrical Subway Co.” (Con Tel and Electrical Subway Company Agreements 1886-1891.pdf)

⁴² Syracuse City Code §6-203, L.L. No. 22-1989, § 25.

Standby Tariff

Customers operating private generating facilities to cover part of their load while receiving backup or supplementary power from the utility will be subject to National Grid's standby tariff⁴³ unless they are otherwise exempt.⁴⁴ Under current standby rate design, National Grid recovers the cost of supplying supplemental power through three distinct charges: customer charges, contract demand charges, and daily as used demand charges. The customer charge is designed to recover certain fixed costs, such as metering expenses and administrative costs that do not vary with energy use. The customer charge shows up on the customer's bill as a fixed monthly charge.

The standby contract demand charge is intended to recover variable costs associated with distribution infrastructure dedicated to the customer (e.g. nearby infrastructure that only serves the single customer). The contract demand charge is based on the customer's maximum metered demand during some previous 12 month period of time. The charge is levied regardless of whether the customer's actual maximum peak demand approaches the level at which the charge is set.

The actual level at which the contract demand charge is set can be established by the customer or National Grid. If the customer opts to set their own contract demand charge, penalties can be levied if the charge is exceeded, while a charge set by the utility is not subject to penalties. Exceedance penalties will result in a surcharge equal to between 12 to 24 times (depending on the level of exceedance) the sum of the monthly demand charges for the demand in excess of the contract demand.

The daily as-used demand charge is designed to recover the costs of distribution infrastructure needed to meet the entire system's demand peaks. Therefore, the charge is assessed based upon the customer's daily maximum metered demand during peak-hour periods on the macrosystem.

Standby rates are under reexamination as part of the REV proceeding. Staff has noted that "the methodology for allocating costs that determine the contract demand and as-used demand components of standby rates should be reviewed in this new [REV] context."⁴⁵ The manner in which these rates change cannot be forecast at this time.

Community Net Metering

In July 2015, the PSC established a community net metering regime⁴⁶ that has since been incorporated into National Grid's tariffs.⁴⁷ Qualifying generation assets include those that would be eligible under net metering (See Section I(2)(A) above). Under community net metering, a project sponsor could size eligible generators far beyond the demand of a host utility account and distribute retail-value net metering credit to a set of "subscribing" customers in the same utility service territory. This may be a substantial value-added to the rate paid on qualifying generation assets for power exported to the utility.

⁴³ National Grid Service Classification SC-7-Sale of Standby Service to Customers with On-Site Generation Facilities.

⁴⁴ In April 2015, the Commission expanded exemptions to standby rates, notably by permitting exemption for CHP system up to 15 MW. Exemptions also apply to fuel cells, wind, solar thermal, photovoltaic, biomass, tidal, geothermal, and methane waste-powered generation. See Case 14-E-0488, "Order continuing and Expanding the Standby Rate Exemption," (Apr. 20, 2015).

⁴⁵ Case 14-M-0101, "Staff Whitepaper on Ratemaking and Utility Business Models," (July 28, 2015).

⁴⁶ Case 15-E-0082, "Order Establishing a Community Distributed Generation Program and Making Other Findings," (July 17, 2015).

⁴⁷ PSC NO 220, Electricity, Leaf 148.

Residential/Non-Residential DG Gas Rate

A distributed generation rate is established in National Grid's territory, available "to customers who demonstrate the ability to operate at a minimum load factor of 50%, within the first year of service, and have Distributed Generation units with capacity of less than 50 MW."⁴⁸ This rate may be economically advantageous for the CHP components of the microgrid, although customers should compare costs against a Transportation Rate or the price offered by a third-party gas marketer, as these may also propose a cost-effective solution.

Cost of Gas Service Upgrades

Microgrids that incorporate new natural gas-fired generators or CHP systems may require the delivery of substantially more natural gas to the site than was previously provided by the utility. If the additional natural gas demand exceeds the current infrastructure's capacity, the relevant natural gas mains, service piping and related facilities will need to be upgraded for the project to succeed. The requirements of utilities and gas upgrade applicants regarding gas service upgrades are governed by 16 NYCRR §230. Prior to any upgrades, the applicant must sign an agreement to assure National Grid that he/she will be a reasonably permanent customer, pay the utility for any installation and materials costs beyond the costs the utility is required to bear, and pay a rate for future gas delivery charged to similarly situated customers.⁴⁹ Section §230.2 outlines the "100 foot rule," which requires gas utilities to install up to 100 feet of main and service line extensions and related facilities at no cost to the applicants.⁵⁰ Utilities can bear the cost of extensions and additional facilities beyond 100 feet if the utility deems the expansion to be cost justified.⁵¹ This situation, however, is relatively rare, and utilities will often require the applicant to pay for any installation and material costs beyond 100 feet.

Distributed generation that is designed to receive gas at high inlet pressures may be more economical in cases where it can receive gas service directly from the utility company's high pressure transmission lines, rather than the comparatively lower pressure distribution lines that service most customers.⁵² This might save a customer-generator the cost of buying and maintaining gas compressors that raise the gas pressure to appropriate inlet levels. In such a case, the customer must typically apply to the utility company for a dedicated service line at high pressure connecting to the transmission line, which would be built and paid for under the same set of rules the govern gas service upgrades, described above.

⁴⁸ PSC NO 219, Gas, Leaf 215.

⁴⁹ 16 NYCRR § 230.2(b).

⁵⁰ 16 NYCRR § 230.2 (c), (d), and (e).

⁵¹ 16 NYCRR § 230.2 (f). Methods for determining cost-justified upgrades are set forth in each utility's tariff. For example, Con Edison analyzes whether the projected net revenue derived from the potential customer will cover the cost to install the service line beyond the 100 ft. maximum. If so, Con Edison will provide line upgrades beyond 100 feet at no cost to the customer.

⁵² Different types of natural-gas powered DG may or may not require higher pressure gas service. E.g., small scale reciprocating engines do not require high pressure gas lines to operate. A sub 500kwe unit may require 0.3(min)-0.8(max) PSIG input pressure. Small scale microturbines may require higher gas input pressure of about 75-80PSIG.

Task 4. Benefit Cost Analysis

Project Overview

As part of NYSERDA's NY Prize community microgrid competition, Syracuse University has proposed development of a microgrid that would serve numerous facilities in downtown Syracuse. Table 1 identifies the commercial, industrial, and residential facilities that the proposed microgrid would serve. As shown, the facilities include a variety of commercial enterprises, including a commercial architecture firm, a pharmaceutical manufacturing facility, a pharmacy, and a grocery store; several public services, including a fire station, a police station, a community development center, and a church; and three schools that would be used as emergency shelters during a major power outage.

The microgrid would incorporate 39 distributed energy resources (DERs), across seven nodes, with a total nameplate capacity of 6.576 MW. These DERs include eight photovoltaic (PV) units with a combined nameplate capacity of 0.738 MW (including one existing 0.138 MW unit and seven units that would be developed), and 27 new natural gas-combined heat and power (CHP) generators with a combined nameplate capacity of 5.62 MW. The design also utilizes a subset of the existing emergency generators in the event of an outage. These include two existing diesel-fired 0.075 MW emergency generators, and two existing natural gas-fired emergency generators with a combined nameplate capacity of 0.068 MW). All except for the existing emergency generators would produce electricity during periods of normal operation, while the four emergency generators would be used only during a major power outage, when the microgrid would operate in islanded mode.⁵³ Together, the microgrid's DERs would be able to supply sufficient electricity to support average annual usage for all supported facilities, and to keep all facilities fully operational during a major power outage.

To assist with completion of the project's NY Prize Stage 1 feasibility study, IEC conducted a screening-level analysis of the project's potential costs and benefits. This report describes the results of that analysis, which is based on the methodology outlined below.

Methodology and Assumptions

In discussing the economic viability of microgrids, a common understanding of the basic concepts of benefit-cost analysis is essential. Chief among these are the following:

Costs represent the value of resources consumed (or benefits forgone) in the production of a good or service.

Benefits are impacts that have value to a firm, a household, or society in general.

Net benefits are the difference between a project's benefits and costs. Both costs and benefits must be measured relative to a common *baseline* - for a microgrid, the "without project" scenario - that describes the conditions that would prevail absent a project's development. The BCA considers only those costs and benefits that are *incremental* to the baseline.

⁵³ Because the existing PV unit is already installed and operating, the energy it generates under normal operating conditions is not treated as a benefit of the microgrid.

Table 4.1. Facilities Served by Proposed Microgrid

Facility Name	Facility Description
Fire Station #6	Fire station
WCNY	Public broadcasting station
Delavan Center	Large mixed commercial building
King + King Architects	Commercial architecture firm
Steri-Pharma	Pharmaceutical manufacturing facility
Lincoln Supply	Mixed use (residential/commercial)
P.E.A.C.E., Inc.	Low-income community services
CNY Services	Community medical services and housing
Hillside Children’s Center	Community medical and educational services
Seymour School	Dual language academy (would serve as an emergency shelter during a major power outage with a capacity of 1,440)
Huntington Family Center	Community development and educational services
Syracuse Housing Authority	Affordable housing development (500 customers)
St. Joseph’s Hospital	Hospital/medical services
Gifford & West Pharmacy	Commercial pharmacy
Nojaim’s Market	Grocery store
St. Lucy Church	Church
Blodgett School	Public school (would serve as an emergency shelter with a capacity of 2,400)
Rockwest Center	Large mixed commercial building, including a police station
Fowler High School	Public high school (would serve as an emergency shelter with a capacity of 4,000)

This analysis relies on an Excel-based spreadsheet model developed for NYSERDA to analyze the costs and benefits of developing microgrids in New York State. The model evaluates the economic viability of a microgrid based on the user’s specification of project costs, the project’s design and operating characteristics, and the facilities and services the project is designed to support. Of note, the model analyzes a discrete operating scenario specified by the user; it does not identify an optimal project design or operating strategy.

The BCA model is structured to analyze a project’s costs and benefits over a 20-year operating period. The model applies conventional discounting techniques to calculate the present value of costs and benefits, employing an annual discount rate that the user specifies – in this case, seven percent.⁵⁴ It also

⁵⁴ The seven percent discount rate is consistent with the U.S. Office of Management and Budget’s current estimate of the opportunity cost of capital for private investments. One exception to the use of this rate is the calculation of environmental damages. Following the New York Public Service Commission’s (PSC) guidance for benefit-cost analysis, the model relies on temporal projections of the social cost of carbon (SCC), which were developed by the U.S. Environmental Protection Agency (EPA) using a three percent discount rate, to value CO₂ emissions. As the PSC notes, “The SCC is distinguishable from other measures because it operates over a very long time frame, justifying use of a low discount rate specific to its long term effects.” The model also uses EPA’s temporal projections of social damage values for SO₂, NO_x, and PM_{2.5}, and therefore also applies a three percent discount rate to the calculation of damages associated with each of those pollutants. [See: State of New York Public Service Commission. Case 14-M-0101, Proceeding on Motion of the Commission in Regard to Reforming the Energy Vision. Order Establishing the Benefit Cost Analysis Framework. January 21, 2016.]

calculates an annualized estimate of costs and benefits based on the anticipated engineering lifespan of the system’s equipment. Once a project’s cumulative benefits and costs have been adjusted to present values, the model calculates both the project’s net benefits and the ratio of project benefits to project costs. The model also calculates the project’s internal rate of return, which indicates the discount rate at which the project’s costs and benefits would be equal. All monetized results are adjusted for inflation and expressed in 2014 dollars.

With respect to public expenditures, the model’s purpose is to ensure that decisions to invest resources in a particular project are cost-effective; i.e., that the benefits of the investment to society will exceed its costs. Accordingly, the model examines impacts from the perspective of society as a whole and does not identify the distribution of costs and benefits among individual stakeholders (e.g., customers, utilities). When facing a choice among investments in multiple projects, the “societal cost test” guides the decision toward the investment that produces the greatest net benefit.

The BCA considers costs and benefits for two scenarios:

Scenario 1: No major power outages over the assumed 20-year operating period (i.e., normal operating conditions only).

Scenario 2: The average annual duration of major power outages required for project benefits to equal costs, if benefits do not exceed costs under Scenario 1.⁵⁵

Results

Table 2 summarizes the estimated net benefits, benefit-cost ratios, and internal rates of return for the scenarios described above. The results indicate that if there were no major power outages over the 20-year period analyzed (Scenario 1), the project’s costs would exceed its benefits. In order for the project’s benefits to outweigh its costs, the average duration of major outages would need to equal or exceed 0.23 days per year (Scenario 2). The discussion that follows provides additional detail on these findings.

Table 4.2. BCA Results (Assuming 7 Percent Discount Rate)

ECONOMIC MEASURE	ASSUMED AVERAGE DURATION OF MAJOR POWER OUTAGES	
	SCENARIO 1: 0 DAYS/YEAR	SCENARIO 2: 0.23 DAYS/YEAR
Net Benefits - Present Value	-\$2,550,000	\$30,100
Benefit-Cost Ratio	0.96	1.0
Internal Rate of Return	2.7%	4.9%

⁵⁵ The New York State Department of Public Service (DPS) requires utilities delivering electricity in New York State to collect and regularly submit information regarding electric service interruptions. The reporting system specifies 10 cause categories: major storms; tree contacts; overloads; operating errors; equipment failures; accidents; prearranged interruptions; customers equipment; lightning; and unknown (there are an additional seven cause codes used exclusively for Consolidated Edison’s underground network system). Reliability metrics can be calculated in two ways: including all outages, which indicates the actual experience of a utility’s customers; and excluding outages caused by major storms, which is more indicative of the frequency and duration of outages within the utility’s control. In estimating the reliability benefits of a microgrid, the BCA employs metrics that exclude outages caused by major storms. The BCA classifies outages caused by major storms or other events beyond a utility’s control as “major power outages,” and evaluates the benefits of avoiding such outages separately.

Scenario 1

Figure 4.1 and Table 4.3 present the detailed results of the Scenario 1 analysis.

Figure 4.1. Present Value Results, Scenario 1 (No Major Power Outages; 7 Percent Discount Rate)

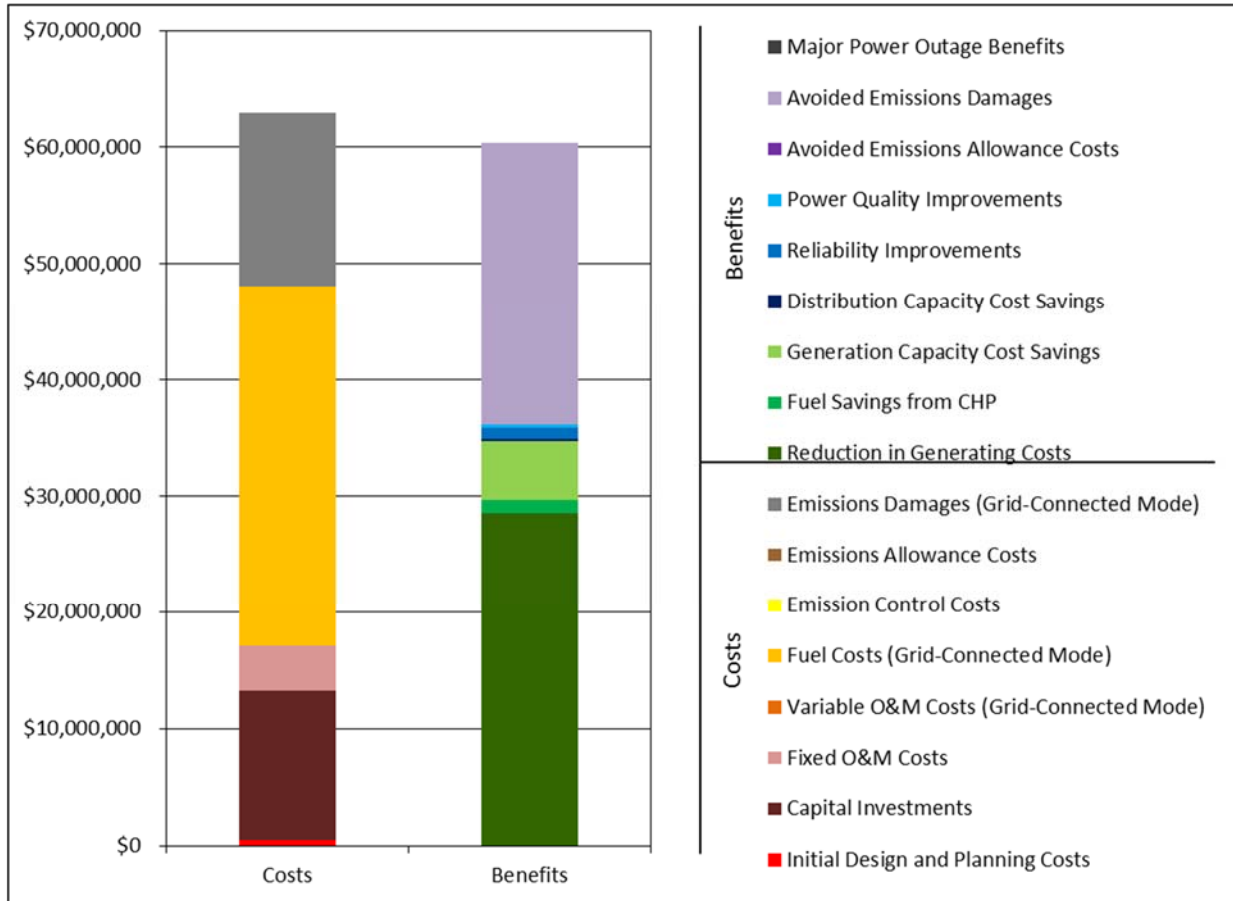

Table 4.3. Detailed BCA Results, Scenario 1 (No Major Power Outages; 7 Percent Discount Rate)

COST OR BENEFIT CATEGORY	PRESENT VALUE OVER 20 YEARS (2014\$)	ANNUALIZED VALUE (2014\$)
Costs		
Initial Design and Planning	\$475,000	\$41,900
Capital Investments	\$12,800,000	\$1,070,000
Fixed O&M	\$3,810,000	\$336,000
Variable O&M (Grid-Connected Mode)	\$0	\$0
Fuel (Grid-Connected Mode)	\$30,900,000	\$2,730,000
Emission Control	\$0	\$0
Emissions Allowances	\$0	\$0
Emissions Damages (Grid-Connected Mode)	\$14,900,000	\$1,320,000
Total Costs	\$63,000,000	
Benefits		
Reduction in Generating Costs	\$28,600,000	\$2,520,000
Fuel Savings from CHP	\$1,130,000	\$99,600
Generation Capacity Cost Savings	\$5,010,000	\$442,000
Distribution Capacity Cost Savings	\$239,000	\$21,000
Reliability Improvements	\$890,000	\$78,600
Power Quality Improvements	\$325,000	\$28,700
Avoided Emissions Allowance Costs	\$15,700	\$1,380
Avoided Emissions Damages	\$24,200,000	\$1,580,000
Major Power Outage Benefits	\$0	\$0
Total Benefits	\$60,400,000	
Net Benefits	-\$2,550,000	
Benefit/Cost Ratio	0.96	
Internal Rate of Return	2.7%	

Fixed Costs

The BCA relies on information provided by the project team to estimate the fixed costs of developing the microgrid. The project team’s best estimate of initial design and planning costs is approximately \$475,000, including development and negotiation of contracts, origination of financing, legal arrangements, and insurance. The present value of the project’s capital costs is estimated at approximately \$12.8 million, including costs associated with acquiring and installing the 34 new DERs and batteries for the PV units; microgrid controllers and software; switch connections; site preparation; and energy efficiency upgrades at all supported facilities. The project team estimates fixed operation and maintenance (O&M) costs (i.e., O&M costs that do not vary with the amount of energy produced) for the system of approximately \$336,000 per year. Over a 20-year operating period, the present value of O&M costs is estimated to be approximately \$3.8 million.

Variable Costs

A significant variable cost associated with the proposed project is the cost of natural gas to fuel operation of the system’s CHP units. To characterize these costs, the BCA relies on estimates of fuel

consumption provided by the project team and projections of fuel costs from New York's 2015 State Energy Plan (SEP), adjusted to reflect recent market prices.⁵⁶ The present value of the project's fuel costs over a 20-year operating period is estimated to be approximately \$30.9 million.

In addition, the analysis of variable costs considers the environmental damages associated with pollutant emissions from the distributed energy resources that serve the microgrid, based on the operating scenario and emissions rates provided by the project team and the understanding that none of the system's generators would be subject to emissions allowance requirements. In this case, the damages attributable to emissions from the microgrid's CHP units are estimated at approximately \$1.3 million annually. The majority of these damages are attributable to the emission of CO₂. Over a 20-year operating period, the present value of emissions damages is estimated at approximately \$14.9 million.

Avoided Costs

The development and operation of a microgrid may avoid or reduce a number of costs that otherwise would be incurred. In the case of Syracuse University's proposed microgrid, the primary source of cost savings would be a reduction in demand for electricity from bulk energy suppliers, with a resulting reduction in generating costs. The BCA estimates the present value of these savings over a 20-year operating period to be approximately \$28.6 million. This estimate takes into account the electricity that the microgrid's CHP units and PV arrays would produce, as well as an anticipated reduction in annual electricity use at the facilities the microgrid would serve.⁵⁷ In addition, the new CHP systems would cut consumption of natural gas for heating purposes; the present value of these savings over the 20-year period analyzed is approximately \$1.1 million. These reductions in demand for electricity from bulk energy suppliers and heating fuel would also reduce emissions of air pollutants, yielding avoided emission allowance costs with a present value of \$15,700 and avoided emissions damages with a present value of approximately \$24.2 million.⁵⁸

In addition to the savings noted above, development of a microgrid could yield cost savings by avoiding or deferring the need to invest in expansion of the conventional grid's energy generation or distribution capacity.⁵⁹ Based on the application of appropriate availability factors for each DER, the analysis estimates the impact of the project on generating capacity requirements to be about 5.72 MW per year. In addition, the project team expects development of the microgrid to reduce the conventional grid's demand for generating capacity by an additional 0.17 MW as a result of new demand response

⁵⁶ The model adjusts the State Energy Plan's natural gas price projections using fuel-specific multipliers calculated based on the average commercial natural gas price in New York State in October 2015 (the most recent month for which data were available). The model applies the same price multiplier in each year of the analysis.

⁵⁷ The project's consultants anticipate an annual reduction in electricity consumption of approximately four percent due to energy efficiency upgrades included with the microgrid. Because the supported facilities have an average annual electricity usage of about 12,000 MWh, these upgrades produce an electricity consumption reduction of about 480 MWh per year.

⁵⁸ Following the New York Public Service Commission's (PSC) guidance for benefit-cost analysis, the model values emissions of CO₂ using the social cost of carbon (SCC) developed by the U.S. Environmental Protection Agency (EPA). [See: State of New York Public Service Commission. Case 14-M-0101, Proceeding on Motion of the Commission in Regard to Reforming the Energy Vision. Order Establishing the Benefit Cost Analysis Framework. January 21, 2016.] Because emissions of SO₂ and NO_x from bulk energy suppliers are capped and subject to emissions allowance requirements in New York, the model values these emissions based on projected allowance prices for each pollutant.

⁵⁹ Impacts on transmission capacity are implicitly incorporated into the model's estimates of avoided generation costs and generation capacity cost savings. As estimated by NYISO, generation costs and generating capacity costs vary by location to reflect costs imposed by location-specific transmission constraints.

capabilities. Based on these figures, the BCA estimates the present value of the project's generating capacity benefits to be approximately \$5.0 million over a 20-year operating period. Similarly, the project team estimates that the microgrid project would reduce the need for local distribution capacity by approximately 0.576 MW per year, yielding annual benefits of approximately \$21,000. Over a 20-year period, the present value of these benefits is approximately \$239,000.

Reliability Benefits

An additional benefit of the proposed microgrid would be to reduce customers' susceptibility to power outages by enabling a seamless transition from grid-connected mode to islanded mode. The analysis estimates that development of a microgrid would yield reliability benefits of approximately \$78,600 per year, with a present value of \$890,000 over a 20-year operating period. This estimate is calculated using the U.S. Department of Energy's Interruption Cost Estimate (ICE) Calculator, and is based on the following indicators of the likelihood and average duration of outages in the service area:⁶⁰

System Average Interruption Frequency Index (SAIFI) – 0.96 events per year.

Customer Average Interruption Duration Index (CAIDI) – 116.4 minutes.⁶¹

The estimate takes into account the number of residential and small and large commercial or industrial customers the project would serve; the distribution of these customers by economic sector; average annual electricity usage per customer, as provided by the project team; and the prevalence of backup generation among these customers. It also takes into account the variable costs of operating existing backup generators, both in the baseline and as an integrated component of a microgrid. Under baseline conditions, the analysis assumes a 15 percent failure rate for backup generators.⁶² It assumes that establishment of a microgrid would reduce the rate of failure to near zero.

It is important to note that the analysis of reliability benefits assumes that development of a microgrid would insulate the facilities the project would serve from outages of the type captured in SAIFI and CAIDI values. The distribution network within the microgrid is unlikely to be wholly invulnerable to such interruptions in service. All else equal, this assumption will lead the BCA to overstate the reliability benefits the project would provide.

Power Quality Benefits

The power quality benefits of a microgrid may include reductions in the frequency of voltage sags and swells or reductions in the frequency of momentary outages (i.e., outages of less than five minutes, which are not captured in the reliability indices described above). The analysis of power quality benefits relies on the project team's best estimate of the number of power quality events that development of the microgrid would avoid each year. The Syracuse University project team estimates that the microgrid would help the facilities it serves avoid an average of about 1.7 power quality events per year. The model estimates the present value of this benefit to be approximately \$325,000 over a 20-year operating period.

Summary

The analysis of Scenario 1 yields a benefit/cost ratio of 0.7; i.e., the estimate of project benefits is approximately 70 percent that of project costs. Accordingly, the analysis moves to Scenario 2, taking into account the potential benefits of a microgrid in mitigating the impact of major power outages.

⁶⁰ www.icecalculator.com.

⁶¹ The analysis is based on DPS's reported 2014 SAIFI and CAIDI values for National Grid.

⁶² <http://www.businessweek.com/articles/2012-12-04/how-to-keep-a-generator-running-when-you-lose-power#p1>.

Scenario 2

Benefits in the Event of a Major Power Outage

As previously noted, the estimate of reliability benefits presented in Scenario 1 does not include the benefits of maintaining service during outages caused by major storm events or other factors generally considered beyond the control of the local utility. These types of outages can affect a broad area and may require an extended period of time to rectify. To estimate the benefits of a microgrid in the event of such outages, the BCA methodology is designed to assess the impact of a total loss of power – including plausible assumptions about the failure of backup generation – on the facilities the microgrid would serve. It calculates the economic damages that development of a microgrid would avoid based on (1) the incremental cost of potential emergency measures that would be required in the event of a prolonged outage, and (2) the value of the services that would be lost.^{63,64}

As noted above, the Syracuse University microgrid project would serve 19 facilities during an extended outage. In the BCA model, several factors influence the costs that would be incurred during a major outage in the absence of a microgrid, including the following:

- Whether or not backup generation currently exists at the facility;
- Whether the facility would rent a backup generator to supply power during an outage;
- The ability of the facility to operate when using backup power;
- The ability of the facility to operate during a complete loss of power;
- The cost of operating existing or rental generators;
- The extent to which the facility incurs costs for emergency measures (e.g., evacuation of patients or staff); and
- The economic value of the services that the facility would cease to provide during an outage.

Table 4.4 summarizes these parameters for six sets of facilities:

- **Emergency Services:** This group includes Fire Station #6, which currently has a backup generator, and the police station in the Rockwest Center facility, which does not. The value of the services provided by these facilities is estimated by the model using methodologies developed by the Federal Emergency Management Agency (FEMA).
- **Residential Facilities:** This group includes three facilities at which the primary impact of a power outage would be the loss of electrical power for household use. The analysis estimates the value of this service using a methodology developed by FEMA. Of the three facilities included in this category (see Table 4), Syracuse Housing Authority is equipped with backup generators, while the other two are not. The project team estimates that the Syracuse Housing Authority would house residents at alternative facilities, at a daily cost of about \$39,000 for both housing and meals. The analysis does not incorporate these costs, however, in order to avoid double counting the lost value of the housing services that this facility provides.
- **Emergency Shelters:** The project consultants indicate that the three schools supported by the microgrid would be used as places of refuge in the event of a major outage. Considered together, the facilities are capable of providing shelter for 7,840 individuals. The total value of

⁶³ The methodology used to estimate the value of selected lost services was developed by the Federal Emergency Management Agency (FEMA) for use in administering its Hazard Mitigation Grant Program. See: FEMA Benefit-Cost Analysis Re-Engineering (BCAR): Development of Standard Economic Values, Version 4.0. May 2011.

⁶⁴ As with the analysis of reliability benefits, the analysis of major power outage benefits assumes that development of a microgrid would insulate the facilities the project would serve from all outages. The distribution network within the microgrid is unlikely to be wholly invulnerable to service interruptions. All else equal, this will lead the BCA to overstate the benefits the project would provide.

services per day (\$392,000) is estimated by multiplying the capacity of the shelter facilities by the American Red Cross estimate of the cost of providing overnight shelter (\$50/person/day). One of the three schools is equipped with a backup generator, and the other two are not.

- **Other Facilities with 50% Service Losses:** This group includes two facilities that would experience a 50% loss in service capabilities when operating on backup power. Of the two facilities in this group, WCNY currently has a backup generator, while Steri-Pharma does not. Using the ICE calculator, the model estimates the value of the services provided by these two facilities to be about \$271,000 per day. The project team estimates that for any power outages lasting more than 48 hours, WCNY would obtain an additional backup generator, at a one-time cost of \$500 and an ongoing cost of \$4,000 per day.
- **Other Facilities with 75% Service Losses:** This group includes three facilities that would experience a 75% loss in service capabilities when operating on backup power. None of the facilities in this group currently has a backup generator. Using the ICE calculator, the model estimates the value of the services provided by these facilities to be about \$222,000 per day.
- **Other Facilities with 80% Service Losses:** This group includes six facilities that would experience an 80% loss in service capabilities when operating on backup power. None of the facilities in this group currently has a backup generator. Using the ICE calculator, the model estimates the value of the services provided by these six facilities to be about \$253,000 per day.

In all cases, the analysis assumes that facilities that do not currently have backup generators would obtain them (at a one-time cost of \$500 and a rental cost of \$1,000 per day) during a major outage. In addition, backup generators are assumed to run 24 hours per day, and each is assumed to have a 15 percent chance of failing.

Table 4.4. Summary of Major Power Outage Parameters, Scenario 2

CATEGORY	FACILITIES INCLUDED	VALUE OF SERVICE (\$/DAY)	PERCENT LOSS IN SERVICE CAPABILITIES DURING AN OUTAGE		GENERATOR COSTS		OTHER EMERGENCY COSTS	
			WITH BACKUP POWER	WITHOUT BACKUP POWER	ONE-TIME	DAILY	ONE-TIME	DAILY
Emergency Services	Fire Station #6, Rockwest Center (police station)	Estimated using FEMA methodology	0% (fire) 80% (police)	100%	\$500	\$1,015	\$0	\$0
Residential Facilities	Lincoln Supply, CNY Services, Syracuse Housing Authority	Estimated using FEMA methodology	53%	100%	\$1,500	\$6,462	\$0	\$0
Emergency Shelters	Seymour School, Blodgett School, Fowler High School	\$392,000	65%	100%	\$1,000	\$2,746	\$0	\$0
Other Facilities with 50% Service Loss while on Backup Power	WCNY, Steri-Pharma	\$271,000	50%	100%	\$500	\$1,180	\$500 ¹	\$4,000 ¹
Other Facilities with 75% Service Loss while on Backup Power	St. Joseph’s Hospital, Gifford & West Pharmacy, Nojaim’s Market	\$222,000	75%	100%	\$1,500	\$3,000	\$0	\$0
Other Facilities with 80% Service Loss while on Backup Power	Delavan Center, King + King Architects, P.E.A.C.E., Inc., Hillside Children’s Center, Huntington Family Center, St. Lucy Church	\$253,000	80%	100%	\$3,000	\$6,000	\$0	\$0
Notes: ¹ Steri-Pharma would obtain an additional backup generator for any power outages lasting longer than 48 hours, incurring a one-time cost of \$500 and ongoing costs of \$4,000 per day.								

Summary

Figure 4.2 and Table 4.5 present the results of the BCA for Scenario 2. The results indicate that the benefits of the proposed project would equal or exceed its costs if the project enabled the facilities it would serve to avoid an average of 0.23 days per year without power. If the average annual duration of the outages the microgrid prevents is less than this figure, its costs are projected to exceed its benefits.

Figure 4.2. Present Value Results, Scenario 2 (Major Power Outages Averaging 0.23 Days/Year; 7 Percent Discount Rate)

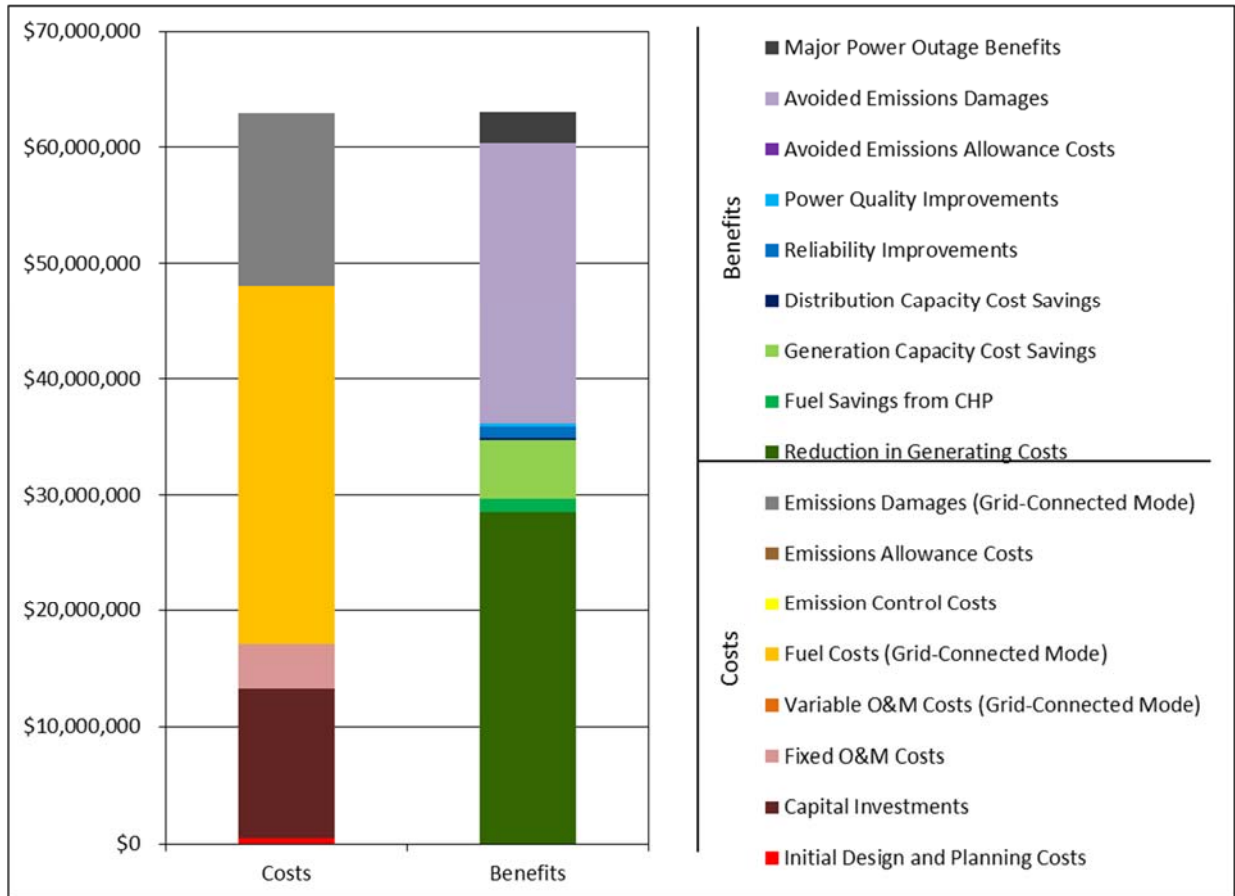

Table 4.5. Detailed BCA Results, Scenario 2 (Major Power Outages Averaging 0.23 Days/Year; 7 Percent Discount Rate)

COST OR BENEFIT CATEGORY	PRESENT VALUE OVER 20 YEARS (2014\$)	ANNUALIZED VALUE (2014\$)
Costs		
Initial Design and Planning	\$475,000	\$41,900
Capital Investments	\$12,800,000	\$1,070,000
Fixed O&M	\$3,810,000	\$336,000
Variable O&M (Grid-Connected Mode)	\$0	\$0
Fuel (Grid-Connected Mode)	\$30,900,000	\$4,340,000
Emission Control	\$0	\$0
Emissions Allowances	\$0	\$0
Emissions Damages (Grid-Connected Mode)	\$14,900,000	\$1,320,000
Total Costs	\$63,000,000	
Benefits		
Reduction in Generating Costs	\$28,600,000	\$2,520,000
Fuel Savings from CHP	\$1,130,000	\$99,600
Generation Capacity Cost Savings	\$5,010,000	\$442,000
Distribution Capacity Cost Savings	\$239,000	\$21,000
Reliability Improvements	\$890,000	\$78,600
Power Quality Improvements	\$325,000	\$28,700
Avoided Emissions Allowance Costs	\$15,700	\$1,380
Avoided Emissions Damages	\$24,200,000	\$1,580,000
Major Power Outage Benefits	\$2,580,000	\$228,000
Total Benefits	\$63,000,000	
Net Benefits	\$30,100	
Benefit/Cost Ratio	1.0	
Internal Rate of Return	4.9%	

Conclusions

The NY Prize feasibility assessment indicates that the Syracuse Near Westside Community Microgrid is technically viable, and may be economically viable if additional funding sources are secured.

The project team believes that the proposed microgrid design will provide valuable lessons for other communities considering developing microgrids within economically vulnerable neighborhoods. The microgrid would protect the welfare of economically disadvantaged residents in emergencies, and help to prevent further economic hardship by allowing them to shelter in place. The microgrid would also incentivize new tenants to move in to commercial properties included in the microgrid by providing a highly reliable energy supply.

The feasibility assessment also revealed some challenges that will be faced in development of this microgrid:

Credibility of Residents: As the Syracuse Near Westside Neighborhood is an economically distressed community, there are many service organizations and non-profits located in the neighborhood to aid the vulnerable population. Such organizations, in addition to the residents, are unlikely to meet minimum standards for financing. In such situations, there must be a way to backstop or credit these facilities through government agencies such as the NY Green Bank. Large third-party financing of community microgrids in New York will be feasible only if some of these creditworthiness risks can be affordably backstopped. Without a financial solution, it is likely that one-third of NY's citizens (the low-income and vulnerable populations, especially those in housing authorities) will not be able to afford resilience in energy supply including times of major storms.

Community Microgrid Financing Costs: The cost of project financing is high for community microgrids. This is due to the fact that there are numerous stakeholders and potential customers, and that each customer has its own procurement requirements. The project team will need to seek out a financier that is knowledgeable about these projects, and can help keep transaction costs to a minimum.

Financial Prospects: As currently envisioned, the Syracuse Near Westside Community Microgrid project is not likely to meet the financial requirements for third-party financing and ownership. In order to meet these requirements, the envisioned project would require sources of additional funding. Possible sources include an award from NY Prize Stage 3 (or equivalent program).

Utility Engagement: National Grid provided valuable information for enhancements to the planned microgrid, but is unable to commit to integration of the Neighborhood Energy Resources or other microgrid components at this time. The project team intends to continue to discuss the envisioned microgrid with National Grid and how a microgrid might utilize existing utility resources effectively.

Next Steps: Based on the findings of this feasibility analysis, there are several next steps that the project team intends to pursue. First, the project team will solicit feedback from each stakeholder regarding their levels of interest and commitment in participating in a community microgrid. The team may consider identifying additional facilities that would be good candidates for inclusion in the microgrid based on their criticality and potential to improve project economics. Based on the final customer list, the project should be remodeled to estimate the technical and economic impact of any additions or subtractions.

Once the model is final the project team will need to make a go/no go decision about moving forward. If a decision is made to move forward, a project team will need to be finalized, and a detailed design developed for the project.

Appendices

Appendix A: Syracuse Near Westside Microgrid Layout Diagram

Appendix B: Syracuse Near Westside Microgrid One-Line Diagram

Appendix C: Potential Individual Resident Service Block Locations, Population, Households

Appendix D: Development of Hourly Load Profiles

Appendix A: Syracuse Near Westside Microgrid Layout Diagram

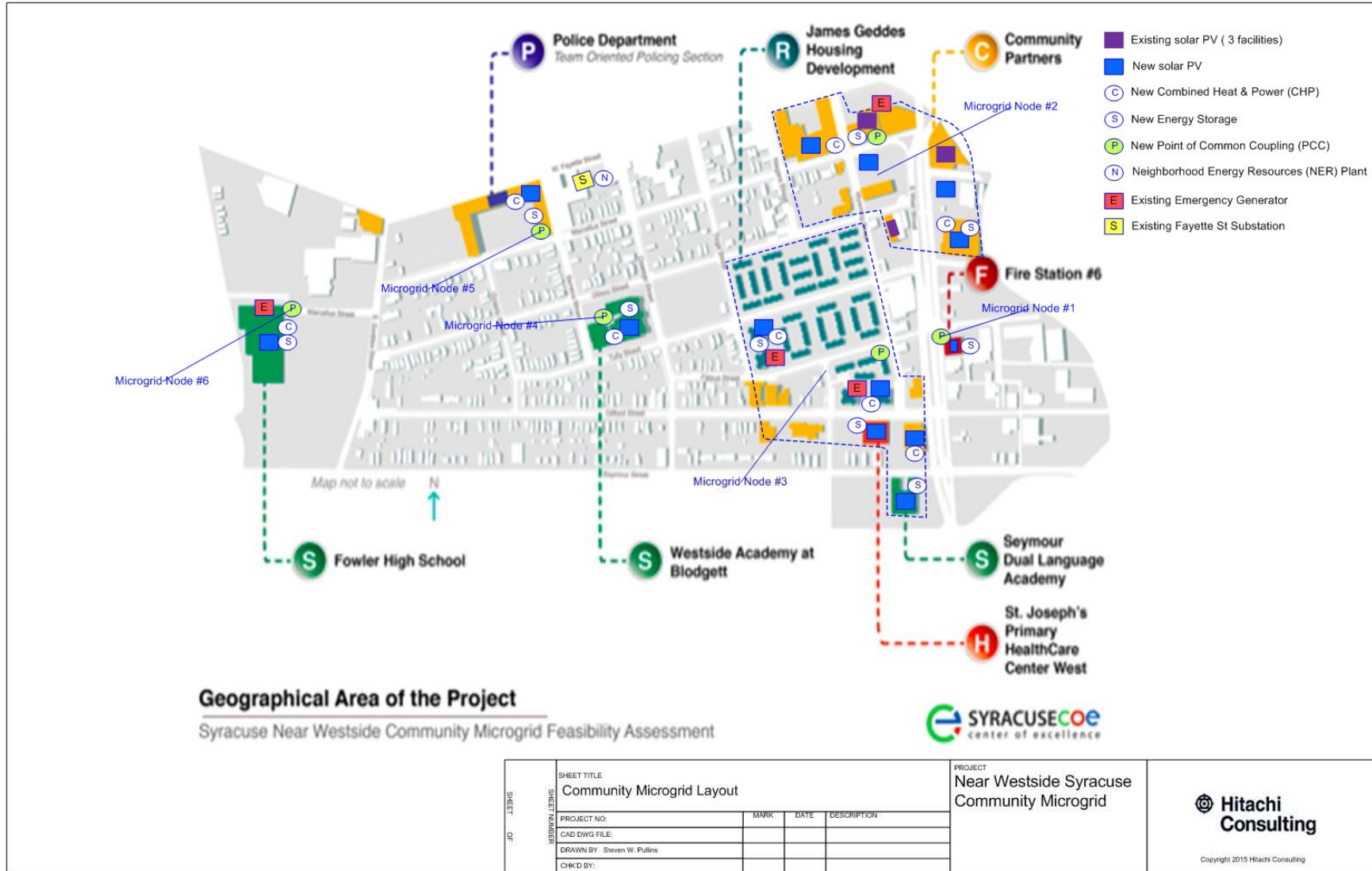

Appendix B: Syracuse Near Westside Microgrid One-Line Diagram

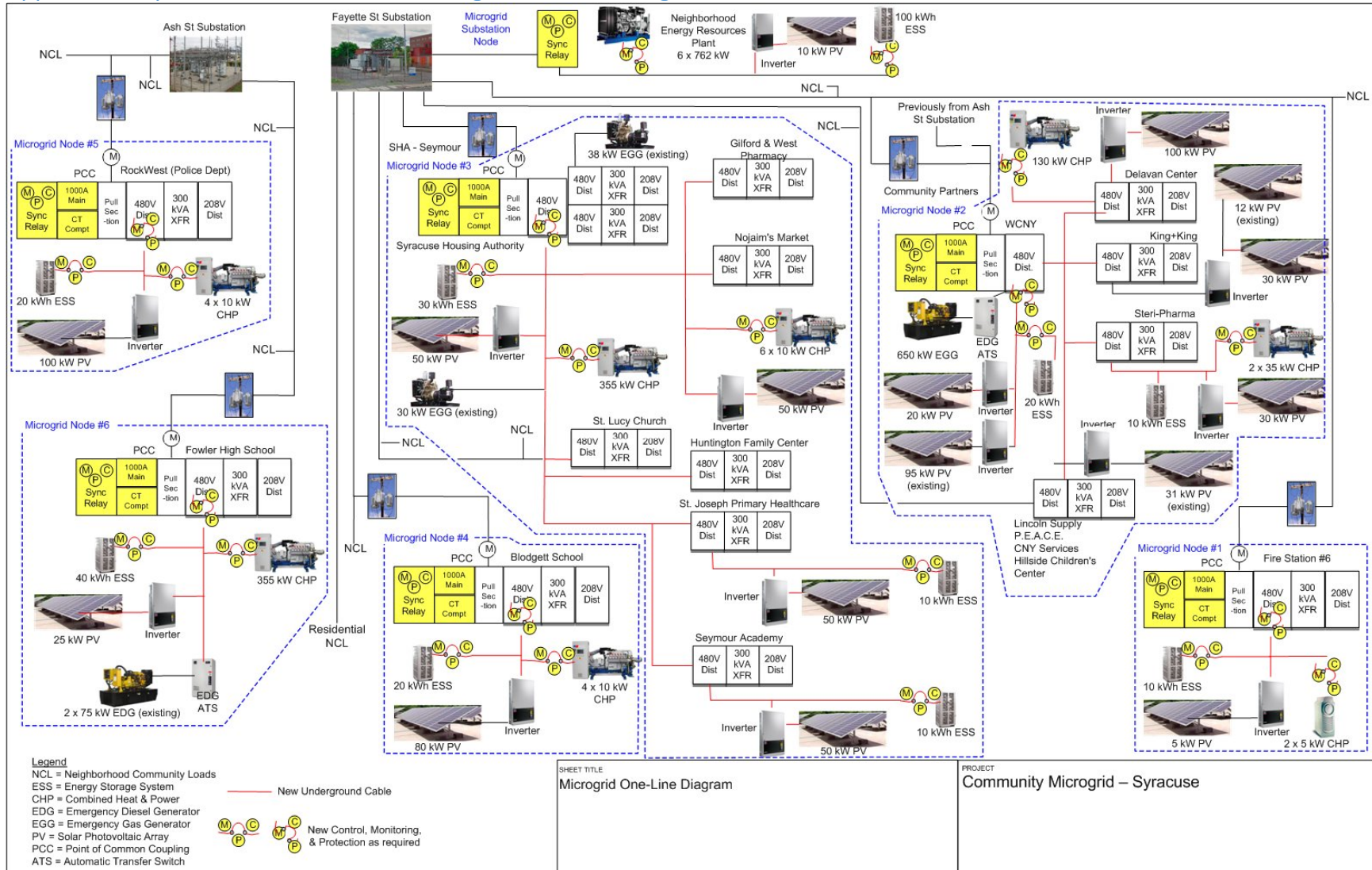

Appendix C: Syracuse Near Westside Nodal Diagrams

One-Line Diagram Explanation

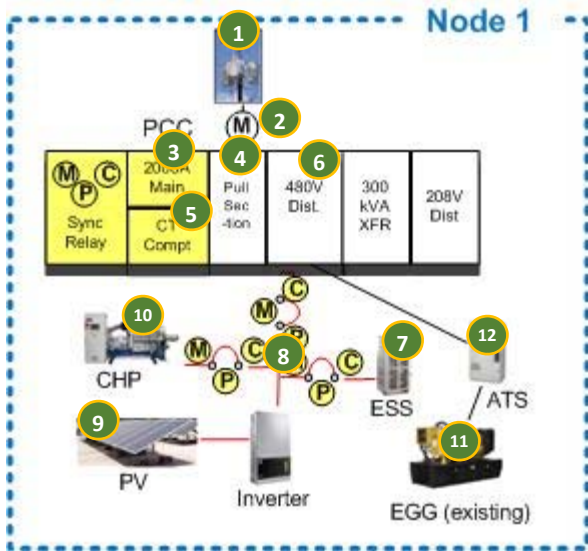

1. Transformer to the critical facility
2. Utility meter
3. Synchronizing relay controls / main breaker with monitoring, protection relays, and controls
4. Main disconnect (pull section)
5. Instrument current transformer compartment
6. Main 480 Volt 3-phase distribution panel; step-down transformer and 208V 1-phase distribution panel
7. Energy storage system (ESS) with M, C, P
8. New 480 Volt 3-phase cable (red)
9. Solar PV array and associated inverter
10. Combined Heat & Power (CHP)
11. Emergency generators: Emergency Gas Generator (EGG) or Emergency Diesel Generator (EDG)
12. Automatic Transfer Switch (ATS)

The following pages highlight the layout design and one-line diagram subsection for each node as well as a brief explanation of included energy resources.

Node 1 System Configuration
Geospatial Diagram

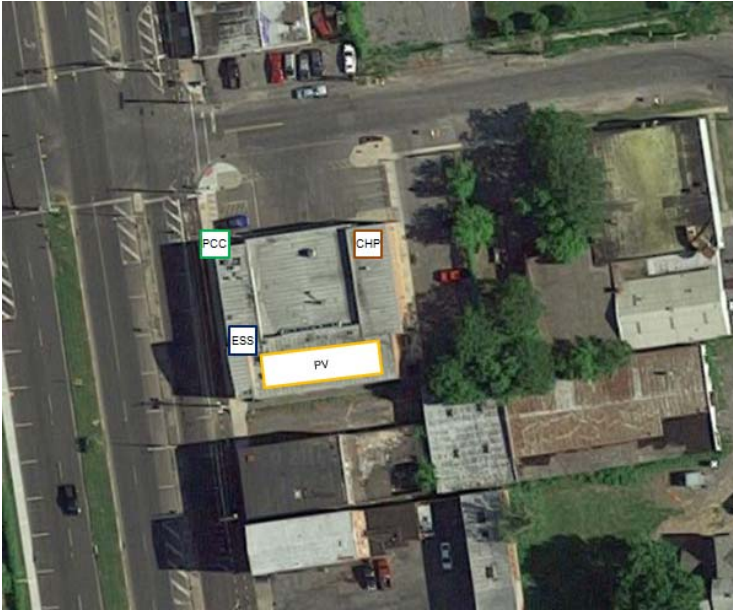

One-Line Diagram Excerpt

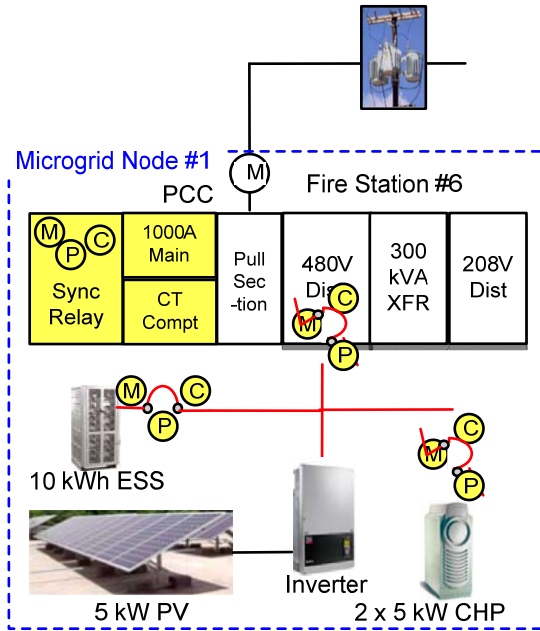

Facilities

- Fire Station #6

Description

Node 1 is a single facility node. The PCC will be located in the Northwest corner of the facility.

As part of the microgrid, the following will be installed:

- **PV (5 kW):** A PV system will be placed on the roof.
- **CHP (10 kW):** Two CHP units will be placed outside of the facility.
- **ESS (10 kWh):** An ESS unit will be placed inside the facility.

Node 2 System Configuration

Geospatial Diagram

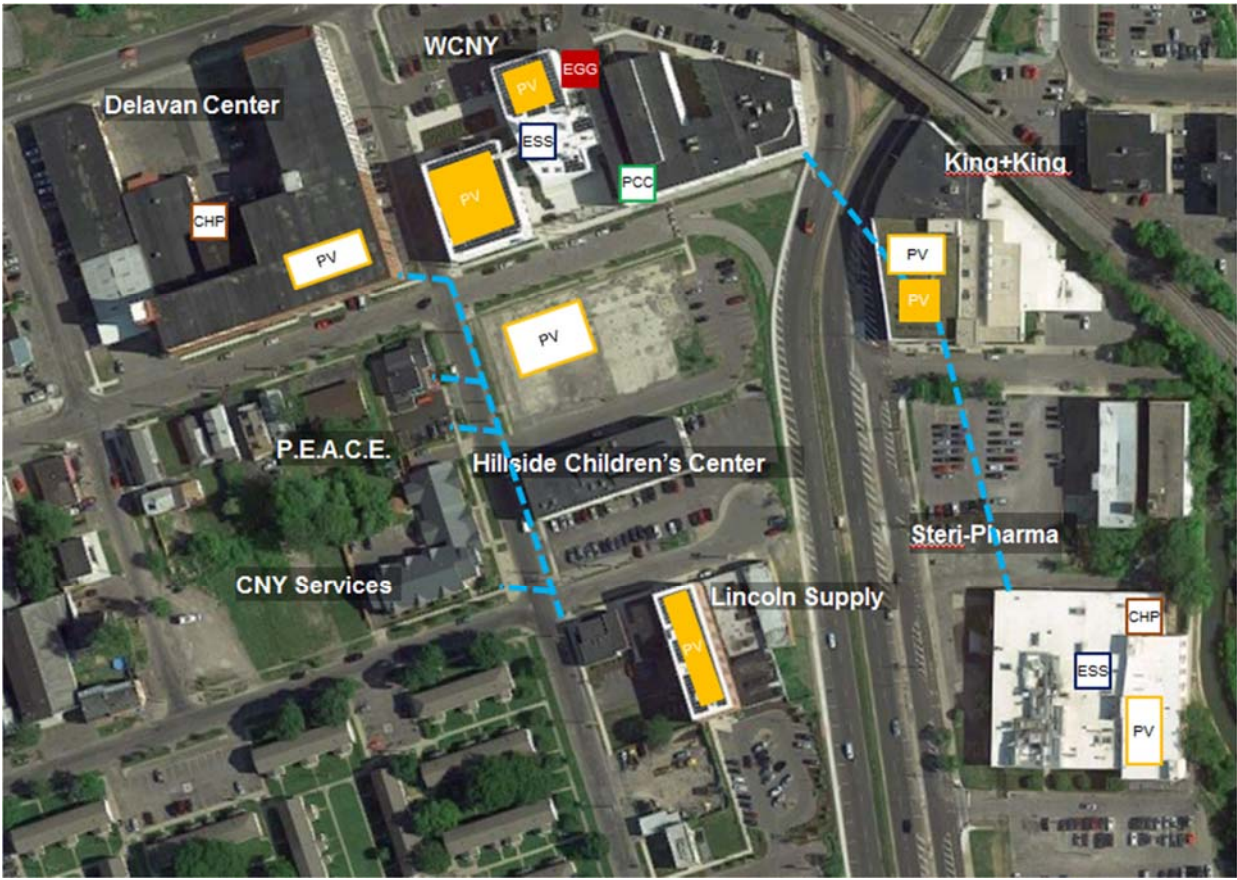

One-Line Diagram Excerpt

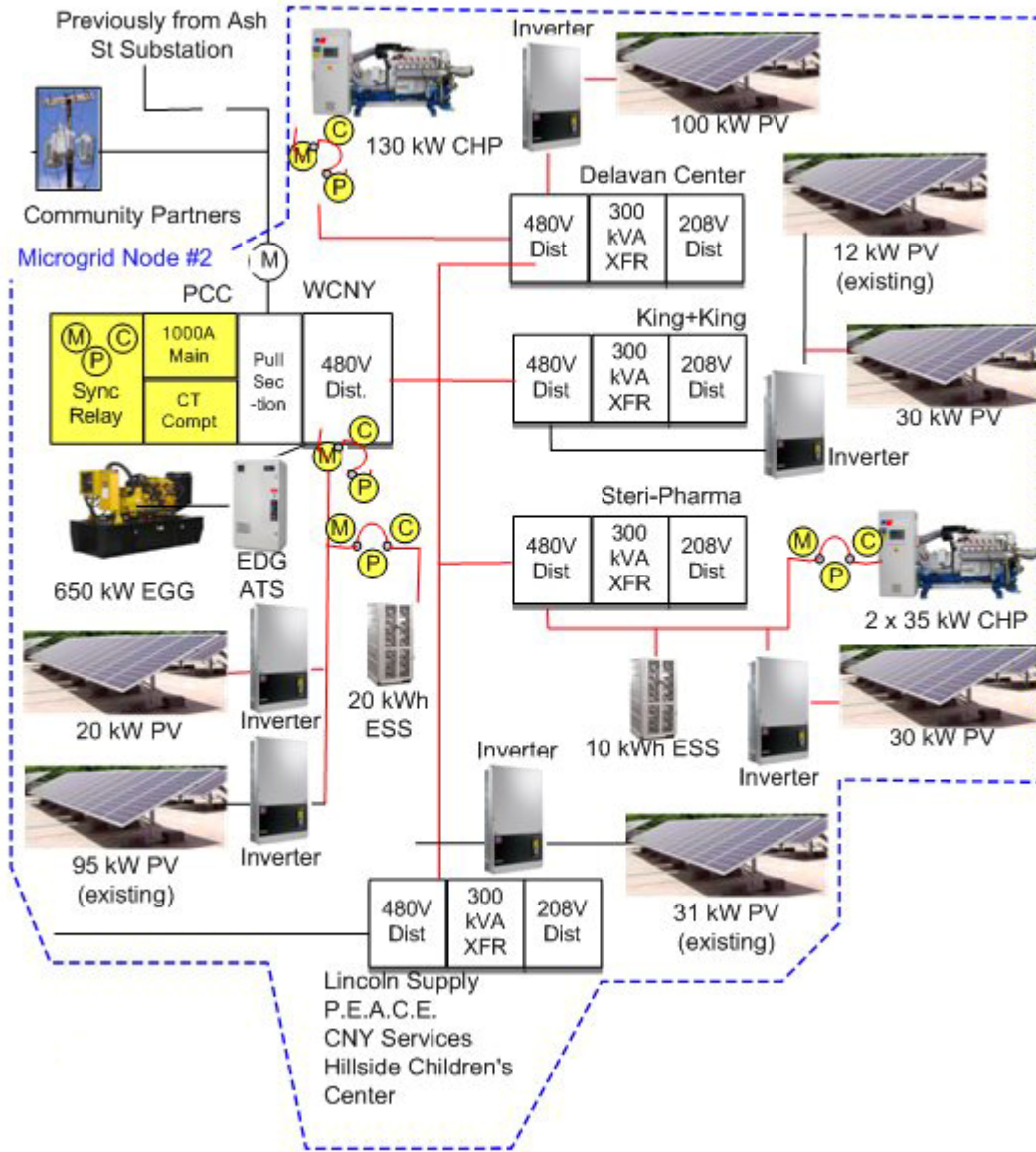

Facility

- WCNY
- Delavan Center
- King+King
- Steri-Pharma
- Lincoln Supply
- P.E.A.C.E.
- CNY Services

- Hillside Children’s Center

Description

Node 2 is a multi-facility node. It includes an existing 95 kW PV array on the WCNV facility, a 31 kW PV array on the Lincoln Supply facility, and a 12 kW PV array on the King + King facility. The PCC will be located near the WCNV facility.

As part of the microgrid, the following will be installed:

- **PV (100 kW):** A PV system will be placed on the roof of the Delavan Center.
- **PV (30 kW):** A PV system will be placed on the roof of the King + King facility.
- **PV (30 kW):** A PV system will be placed on the roof of the Steri-Pharma facility.
- **PV (20 kW):** A PV system will ground mounted next to the WCNV facility.
- **CHP (130 kW):** A CHP unit will be placed outside the Delvan Center facility.
- **CHP (70 kW):** Two CHP units totaling 70 kW will be placed outside the Steri-Pharma facility.
- **ESS (10 kWh):** An ESS unit will be placed inside the Steri-Pharma facility.
- **ESS (20 kWh):** An ESS unit will be placed inside the WCNV facility.

One-Line Diagram Excerpt

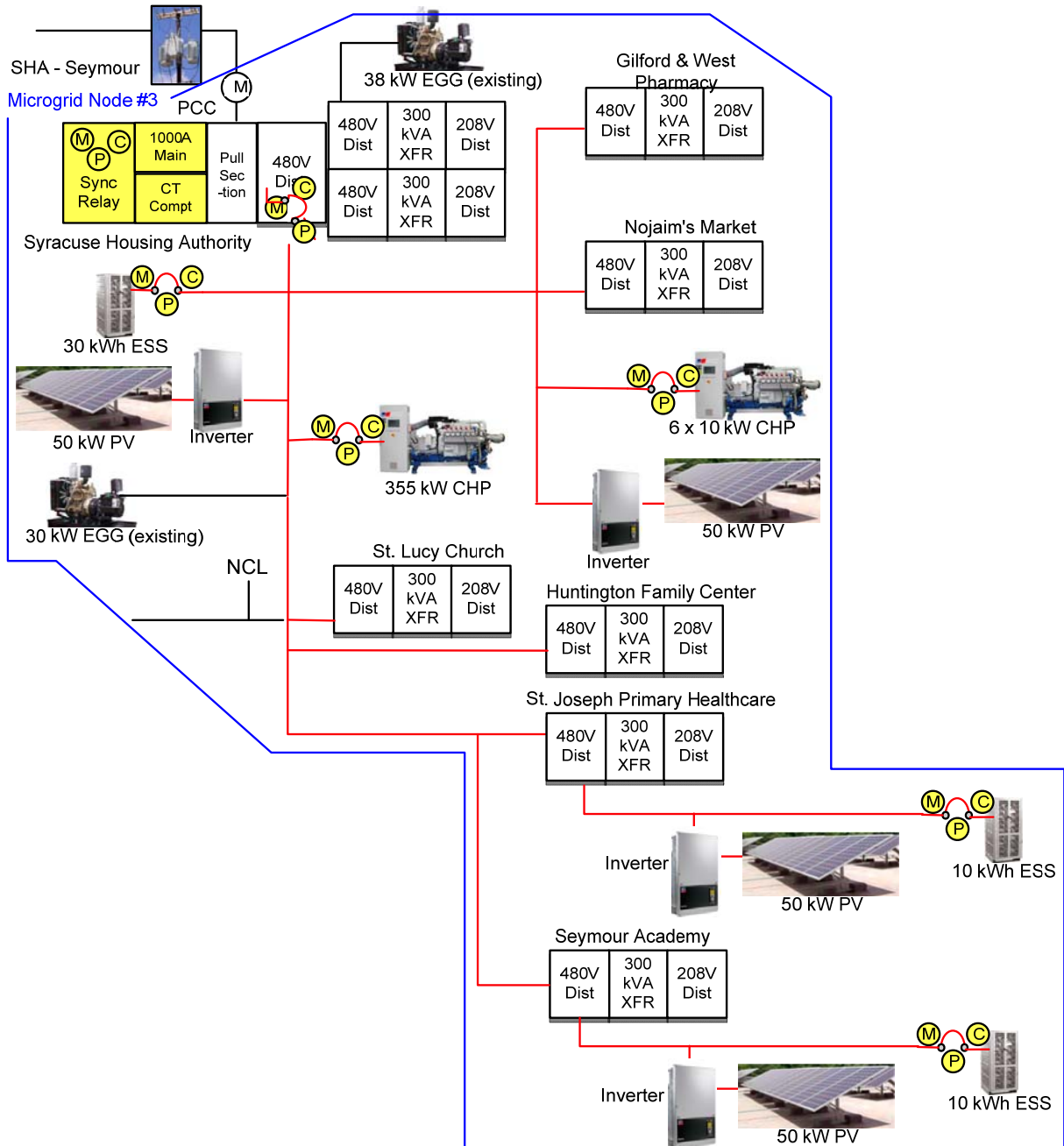

Facility

- Syracuse Housing Authority
- Gilford & West Pharmacy
- Nojaim's Market
- St. Lucy Church
- Huntington Family Center

- St. Joseph Primary Healthcare
- Seymour Academy

Description

Node 3 is a multi-facility node. It includes two existing Emergency Gas Generator, one at 38 kW and one at 30 kW at the Syracuse Housing Authority site. The PCC will be located Northwest of the Gilford & West Pharmacy on the Syracuse Housing Authority site.

As part of the microgrid, the following will be installed:

- **PV (50 kW):** A PV system totaling 50kW will be placed on the roofs of Nojaim’s Market and Gilford & West Pharmacy.
- **PV (50 kW):** A PV system will be placed on the roof of the St. Joseph Primary Healthcare facility.
- **PV (50 kW):** A PV system will be placed on the roof of the Seymour Academy facility.
- **PV (50 kW):** A PV system totaling 50kW will be placed across the roofs of four Syracuse Housing Authority facilities.
- **CHP (60 kW):** Six CHP units totaling 60 kW will be placed outside next to the Nojaim’s Market facility.
- **CHP (355 kW):** A CHP unit will be placed outside the Syracuse Housing Authority towers on West edge of the site.
- **ESS (10 kWh):** An ESS unit will be placed inside the St. Joseph Primary Healthcare facility.
- **ESS (10 kWh):** An ESS unit will be placed inside the Seymour Academy facility.
- **ESS (30kWh):** An ESS unit will be placed inside the Syracuse Housing Authority towers on the West edge of the site.

Node 4 System Configuration

Geospatial Diagram



Facility

- Blodgett School

Description

Node 4 is a single facility node. The PCC will be located at the Southwest corner of the facility.

As part of the microgrid, the following will be installed:

- **PV (80 kW):** A PV system will be placed on the roof of the facility.
- **CHP (40 kW):** Four CHP units totaling 40kW will be outside the facility.
- **ESS (20 kWh):** An ESS unit will be placed near the PV system inverters.

One-Line Diagram Excerpt

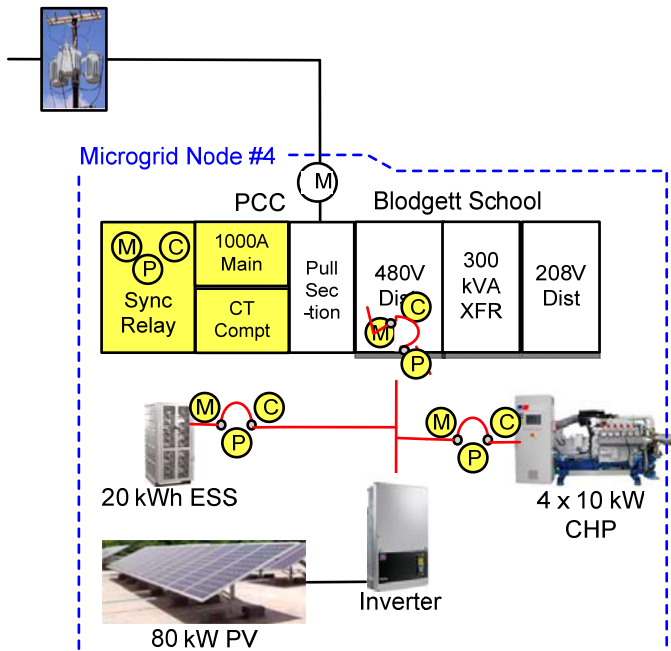

Node 5 System Configuration

Geospatial Diagram

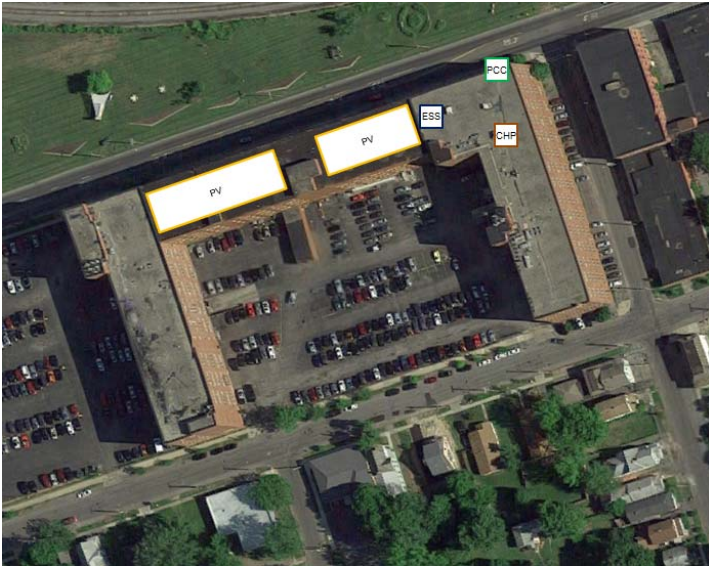

One-Line Diagram Excerpt

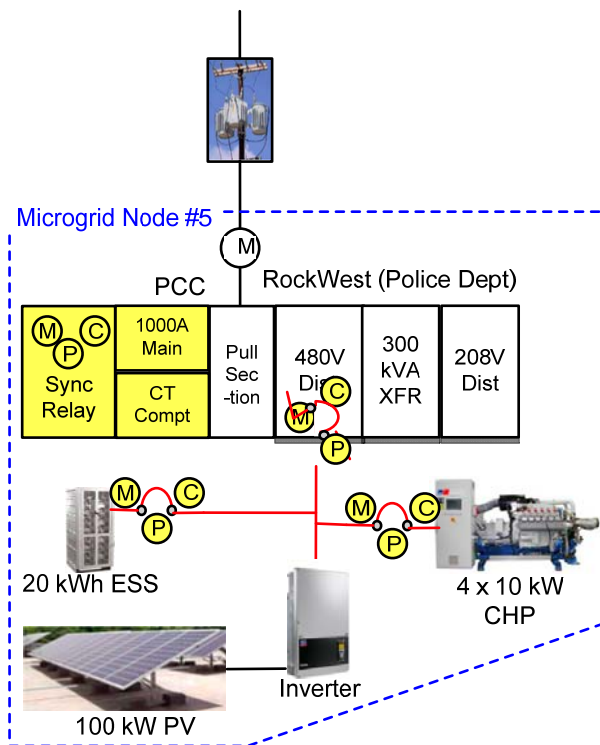

Facilities

- RockWest (Police Dept)

Description

Node 5 is a single facility node. The PCC will be located at the Northeast corner of the facility.

As part of the microgrid, the following will be installed:

- **PV (100 kW):** A PV system will be placed on the roof of the facility.
- **CHP (40 kW):** Four CHP units totaling 40kW will be outside the facility.
- **ESS (20 kWh):** An ESS unit will be placed near the PV system inverters.

Node 6 System Configuration

Geospatial Diagram

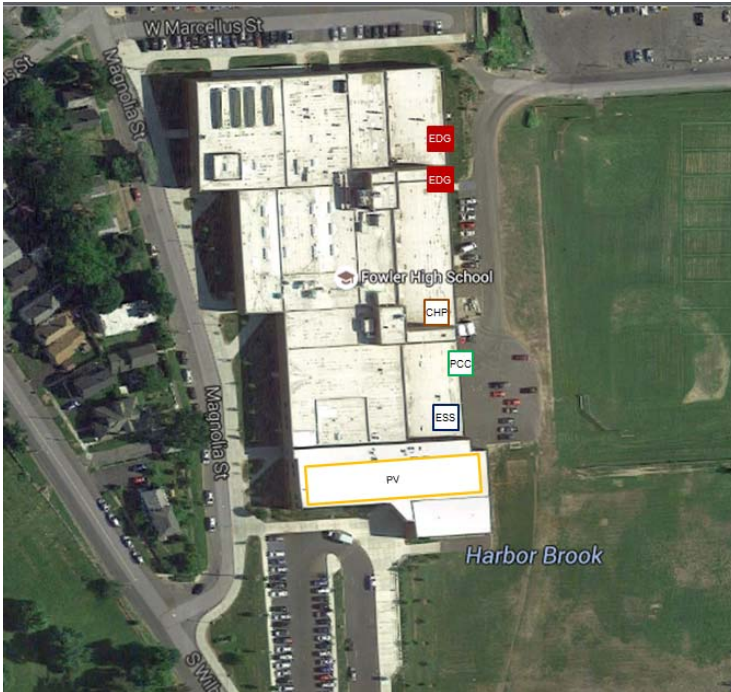

Facilities

- Fowler High School

Description

Node 6 is a single facility node. It includes two existing emergency diesel generators (75 kW each). The PCC will be located on the West side of the facility.

As part of the microgrid, the following will be installed:

- **PV (25 kW):** A PV system will be placed on the roof of the facility.
- **CHP (355 kW):** A CHP unit will be placed outside the facility.
- **ESS (40 kWh):** An ESS unit will be placed near the PV system inverters.

One-Line Diagram Excerpt

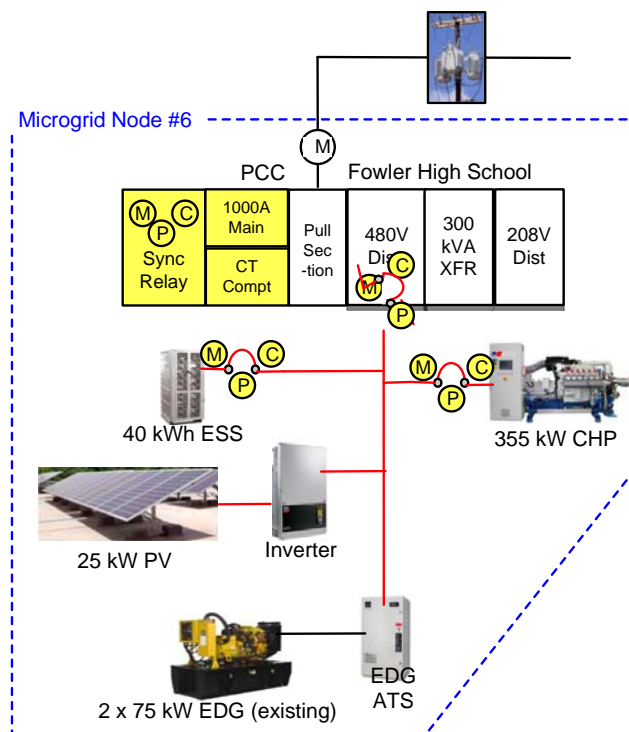

Appendix C: Potential Individual Resident Service Block Locations, Population, Households

Boundaries	Other References	Pop.	Households
Tully, Wyoming, Fabius, Tioga	SHA Towers & Row Houses	371	188
Fabius, Wyoming, Gifford, Niagara	SHA Geddes Towers South	235	139
Holland, Slocum, West Onondaga, Sheridian Place		289	132
Otisco, Wyoming, Tully, Oswego	SHA North Row Houses	354	117
South Geddes, Shonnard, Oswego Merriman		373	117
S Geddes, Gifford, Oswego, Seymour		316	96
West Onondaga, South, White, Rich		162	86
South Geddes, Seymour, Oswego, Shonnard		280	85
South Geddes, Fitch, Dudley, Putnam		248	77
South Geddes, Delaware, Dudley, Fitch		196	68
Shonnard, South West, West Onondaga,		145	67
West Onondaga, Dudley, Bellevue, Bradley		154	67
Holland, Sheridan Place, West Onondaga,		204	64
West Onondaga, Onondaga, Bellevue,		148	63
West Onondaga, Malcolm, Bellevue, Dudley		179	55
Seymour, Niagara, Shonnard, Oswego		198	50
Grace, Congress, Kellogg, Massena		189	48
Davis, Barrett, Sabine, Delaware		183	47
Merriman, Massena, Davis, Barrett		178	46
Kellogg, Oswego, Holland, Massena		147	46
Delaware, West Onondaga, Fitch, Dudley		145	46
West Onondaga, Putnam, Dudley, Fitch		115	44
Tully, Oswego, Gifford, Ontario		131	42
Midland, Tallman, Lincoln		112	42
Kellogg, Slocum, Holland, Congress		120	41
Seymour, West Onondaga, S West		68	41
West Onondaga, Midland, Lincoln, Tallman,		103	39
Putnam, Dudley, Elliot, Rowland, Bradley		110	38
S Geddes, Otisco, Ontario, Gifford		124	35
Gifford, Niagara, Seymour, Oswego		118	35
Grace, Massena, Kellogg, Delaware		126	35
Sabine, Massena, Grace, Delaware		117	34
West Onondaga, Dudley, Elliot, Putnam		143	34
Marcellus, Seneca, Otisco, Ontario		98	33
Otisco, Seneca, Tully, Ontario		117	33
South Geddes, Merriman, Barrett, Davis		101	33
Merriman, Grace, Massena, Sabine		113	33
Davis, Massena, Sabine, Barrett		135	33
South, Tallman, Rich, White		91	33

West Onondaga, Rich, Tallman		82	32
Kellogg, Massena, Holland, Delaware		83	30
South Geddes, Putnam, Bradley, Rowland		81	29
West Onondaga, Onondaga Place, East		37	28
South Geddes, Elliot, Bradley, West		70	28
South Geddes, West Onondaga, Bradley		91	27
Marcellus, Niagara, Otisco, Tioga		63	26
Tully, Tioga, Fabius, Oswego		60	25
Marcellus, Ontario, Otisco, S Geddes		66	23
Elliot, Dudley, West Onondaga, Bradley		76	23
Shonnard, Slocum, Kellogg, Merriman		89	21
Marcellus, Tioga, Otisco, Oswego		56	20
Fabius, Niagara, Gifford, Oswego	Saint Lucy's Church	65	20
Gifford, S West, Seymour, Niagara	Nojaim Bros. Supermarket	62	20
Marcellus, Wyoming, Otisco, Niagara		43	17
Merriman, Massena, Sabine		59	17
South Geddes, Rowland, Bradley, Elliot		44	17
S West, Gifford, Granger, Seymour		19	16
Midland, West Taylor, Tallman, Onondaga		40	15
Midland, Temple, King, West Taylor		47	14
Otisco, Ontario, Central, Belmont		49	13
S West, Fabius, Granger, McCormick	Fire Station 6	21	13
Granger, Dickerson, Gifford		168	13
W Fayette, Oswego, Marcellus, Seneca		33	12
Merriman, Kellogg, Congress		40	12
W Fayette, Tioga, Marcellus, Oswego		21	9
Gifford, Granger, Seymour		131	8
Seymour, S West, Shonnard, Niagara		11	8
S West, McCormick, Granger, Gifford		7	6
W Fayette, Niagara, Marcellus, Tioga		15	4
West Onondaga, Onondaga Place, Temple		9	2
S Geddes, W Fayette, Seneca, Marcellus		10	1
Fabius, S West, Gifford, Wyoming		3	1
Rowland, Elliot, Bradley		3	1

Appendix D: Development of Hourly Load Profiles

Electric Load Profile

The project team used licensed HOMER Pro® microgrid modeling software (as described above) to generate electrical load profiles for the proposed Syracuse microgrid design. The project team employed a data retrieval and pre-modeling process in order to generate inputs for the software. First, the project team requested the most recent twelve-month period of electric usage (kWh), peak demand (kW), and cost data from community stakeholders for each facility under consideration for inclusion in the design. Using a proprietary Hitachi pre-modeling tool, this data was used to estimate hourly load by facility over a twelve-month period. In some cases, fifteen-minute interval data was available, which the project team used to create the hourly load profiles directly (this is applied to the Fowler High School).

The Hitachi pre-modeling tool was designed to take the set of available monthly usage and peak demand data, and, based on preset hourly loads for a variety of building types (commercial, industrial, residential, etc.) defined by the HOMER Pro® microgrid modeling software, generate an hourly load profile per month for each building. Then, the set of available peak demand data was used to manually adjust the pre-populated hourly load profile until the total usage for each month was within +/- ten percent of the actual given usage. The project team determined that +/- ten percent was an acceptable confidence interval to satisfy the overall +/- thirty percent confidence interval required for this NY Prize Stage 1 analysis. This manual manipulation was employed only in instances where the pre-populated hourly load profile yielded total monthly usage values outside of the +/- ten percent confidence interval, generating a more accurate depiction of peak and hourly load profiles that are characteristic across the portfolio of unique buildings within Syracuse.

The output values from this pre-modeling step were then inserted into the HOMER Pro® microgrid modeling software for simulation, optimization, and analysis (as described above). The HOMER Pro® tool allows for the input of daily load profiles and then adds in some randomness. This process produces one year of hourly load data. To address the potential randomness, HOMER Pro® applies a ten percent day-to-day variability and a twenty percent time-step variability. This level of variability provides for appropriate diversity from estimated loads and potential changes in operation for the clients, due to business needs.

Complete sets of electric data were collected for many of the facilities included in the microgrid as indicated in Table 5. However, for some buildings, stakeholders provided either a subset or none of the requested twelve-month set of data. In these cases, the data from similar-type buildings within the region were used to estimate monthly usage and peak demand based on the relative building area. The project team then applied the same pre-modeling process described above to these sets of data to estimate hourly load. This approach was applied to eight buildings in Syracuse: CNY Services, Delavan Center, Gifford & West Pharmacy, Lincoln Supply, Nojaim's Market, P.E.A.C.E., Steri-Pharma, and St. Lucy Church.

Table A.1 summarizes the electric data collection and load estimate approach for each facility:

Table A.1: Monthly Electric Data Provided to Project Team for Analysis

Facility		Jan	Feb	Mar	Apr	May	Jun	Jul	Aug	Sep	Oct	Nov	Dec
Blodgett School	Usage	X	X	X	X	X	X	X	X	X	X	X	X
	Demand	X	X	X	X	X	X	X	X	X	X	X	X
CNY Services	Usage	<i>Estimated using similar-type building data</i>											
	Demand	<i>Estimated using similar-type building data</i>											
Delavan Center	Usage	<i>Estimated using similar-type building data</i>											
	Demand	<i>Estimated using similar-type building data</i>											
Fire Station #6	Usage	X	X	X	X	X	X	X	X	X	X	X	X
	Demand						X						X
Fowler High School	Usage	X	X	X	X	X	X	X	X	X	X	X	X
	Demand	X	X	X	X	X	X	X	X	X	X	X	X
Gifford & West Pharmacy	Usage	<i>Estimated using similar-type building data</i>											
	Demand	<i>Estimated using similar-type building data</i>											
Hillside Children’s Center	Usage	X	X	X	X	X	X	X	X	X	X	X	X
	Demand	X	X	X	X	X	X	X	X	X	X	X	X
Huntington Family Center	Usage	X	X	X	X	X	X	X	X	X	X	X	X
	Demand	X				X							
King + King Architects	Usage	X	X	X	X	X	X	X	X	X	X	X	X
	Demand	X	X	X	X	X	X	X	X	X	X	X	X
Lincoln Supply	Usage	<i>Estimated using similar-type building data</i>											
	Demand	<i>Estimated using similar-type building data</i>											
Nojaim’s Market	Usage	<i>Estimated using similar-type building data</i>											
	Demand	<i>Estimated using similar-type building data</i>											
P.E.A.C.E.	Usage	<i>Estimated using similar-type building data</i>											
	Demand	<i>Estimated using similar-type building data</i>											
Rockwest (Police Dept)	Usage	<i>Estimated total Rockwest Center load based on the community-provided subset of actual usage/demand data and presets provided in HOMER PRO®</i>											
	Demand	<i>Estimated total Rockwest Center load based on the community-provided subset of actual usage/demand data and presets provided in HOMER PRO®</i>											
Seymour Academy	Usage	X	X	X	X	X	X	X	X	X	X	X	X
	Demand	X	X	X	X	X	X	X	X	X	X	X	X
Steri-Pharma	Usage	<i>Estimated using similar-type building data</i>											

		Demand											
St. Joseph Hospital	Usage	X	X	X	X	X	X	X	X	X	X	X	X
	Demand	X	X	X	X	X	X	X	X	X	X	X	X
St. Lucy Church	Usage	<i>Estimated using similar-type building data</i>											
	Demand	<i>Estimated using similar-type building data</i>											
Syracuse Housing Authority	Usage	X	X	X	X	X	X	X	X	X	X	X	X
	Demand	X	X	X	X	X	X	X	X	X	X	X	X
WCNY	Usage	X	X	X	X	X	X	X	X	X	X	X	X
	Demand			X			X						

Natural Gas Load Profile

Similar to the process for modeling hourly electric load profiles, the project team used licensed HOMER Pro® microgrid modeling software to generate thermal load profiles for the proposed microgrid design. The project team requested the most recent twelve-month period of available natural gas (or fuel oil if applicable) and billing data from community stakeholders for each facility under consideration for inclusion in the design. Using a proprietary Hitachi pre-modeling tool, this data was used to estimate hourly thermal load by facility over a twelve-month period. The output values from this pre-modeling step were then inserted into HOMER Pro® in the same manner as the electric load data discussed above.

Complete sets of natural gas data were collected for many of the facilities included in the microgrid as indicated in Table 6. However, for some buildings, stakeholders provided either a subset or none of the requested twelve-month set of data. In these cases, the data from similar-type buildings within the region were used to estimate monthly usage and peak demand based on the relative building area. The project team then applied the same pre-modeling process described above to these sets of data to estimate hourly load. This approach applied to eight buildings in Syracuse: CNY Services, Delavan Center, Gifford & West Pharmacy, Lincoln Supply, Nojaim’s Market, P.E.A.C.E., Steri-Pharma, and St. Lucy Church.

Table A.2 summarizes the natural gas data collection and load estimate approach for each facility:

Table A.2: Monthly Natural Gas Data Provided to Project Team for Analysis

Facility	Jan	Feb	Mar	Apr	May	Jun	Jul	Aug	Sep	Oct	Nov	Dec
Blodgett School	X	X	X	X	X	X	X	X	X	X	X	X
CNY Services	<i>Estimated using similar-type building data</i>											
Delavan Center	<i>Estimated using similar-type building data</i>											
Fire Station #6					X						X	
Fowler High School	X	X	X	X	X	X	X	X	X	X	X	X
Gifford & West Pharmacy	<i>Estimated using similar-type building data</i>											
Hillside Children’s Center	X	X	X	X	X	X	X	X	X	X	X	X
Huntington Family Center	X				X							
King + King Architects	X	X	X	X	X	X	X	X	X	X	X	X
Lincoln Supply	<i>Estimated using similar-type building data</i>											
Nojaim’s Market	<i>Estimated using similar-type building data</i>											
P.E.A.C.E.	<i>Estimated using similar-type building data</i>											
Rockwest Center (Police Department)	<i>Estimated total Rockwest Center load based on the community-provided subset of actual usage/demand data and presets provided in HOMER PRO®</i>											
Seymour Academy	X	X	X	X	X	X	X	X	X	X	X	X
Steri-Pharma	<i>Estimated using similar-type building data</i>											
St. Joseph Hospital	X	X	X	X	X	X	X	X	X	X	X	X
St. Lucy Church	<i>Estimated using similar-type building data</i>											
James Geddes Housing Development	X					X						
WCNY		X			X							