

September Provider Webinar

Multifamily Building Solutions Network

September 11, 2024



Meeting Procedures

Before beginning, a few reminders to ensure a smooth discussion:

- > The session will be recorded.
- > If you want to ask a question, please submit one to the panelists in the Q&A feature. Questions submitted through Q&A are only visible to panelists. We will address questions at the end.
- > The Chat feature is also open and visible to all attendees and panelists.
- > Slides will be distributed to all providers after the webinar.

Q&A

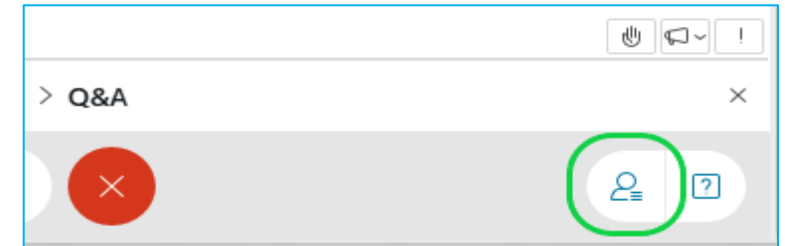

Chat

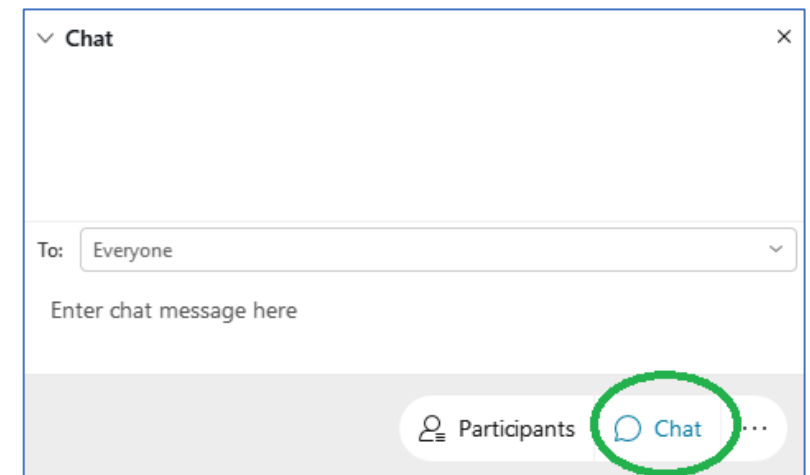

Agenda



Multifamily Updates



OsEM Updates



IRA Update – New Contractor Network



Midea – New Heat Pump Technology



Open Discussion

Multifamily Updates

FlexTech Updates

OsEM (Onsite Energy Manager) Multifamily Offering

- > Anticipate an end of Q3 2024 program rollout
- > Offering will be available statewide to LMI customers at 100% cost share
- > Contracted OsEM may be selected from the current list of NYSERDA MFBSN or an ISP. Support may be sought for a new permanent hire or hybrid or supporting permanent staff with a Consultant.
 - > If a new hire, must secure new hire within 6 months of Purchase Order issuance
- > Same terms and conditions of current OsEM program
 - > Minimum 12-month commitment with a 48-month maximum
 - > Engagement must be 20 hours/week minimum
 - > Cannot already have a dedicated OsEM

OsEM Multifamily- Cost Share

Facility Consumption (aggregated)	OsEM Cost-Share Cap* (initial 12+ month term)	OsEM Bonus #1 (12 months after initial term)	OsEM Bonus #2 (24 months after initial term)	Maximum Possible
Greater than \$1M annual energy spend	Not to exceed \$200,000	\$7,000	\$7,000	\$214,000
Less than \$1M annual energy spend	Not to exceed \$100,000	\$5,000	\$5,000	\$110,000

>OsEM cost share cap dependent on facility consumption

>Customers may be eligible for a bonus payment for each additional year of continued OsEM engagement, capped at 2 additional years

OsEM Multifamily Offering- Deliverables

- > Identify site energy reduction targets, carbon reduction, and electrification goals. Develop a strategy for energy savings M&V
- > Initiate and develop an Energy Management Plan
- > Develop and maintain an energy tracking and monitoring system
- > Develop and maintain a cross functional energy team and hold monthly meetings
- > Propose, evaluate, and implement energy (capital upgrades and operational improvements) and productivity measure list, project descriptions, energy and cost savings analysis, and economic analysis.
- > Quarterly Reports submitted to NYSERDA to provide updates for the above
- > Case study, including savings metrics, for online publishing
- > Road map of the OsEM on-boarding process (including best practices)
- > Final report that documents overall effort and progress against facility energy goal

- > **Questions:** OnsiteEnergyManager@nyserda.ny.gov or Maria Cangiano: Maria.Cangiano@nyserda.ny.gov

Owner's Representative Service

IRA Updates

What are the Home Energy Rebate Programs?

New York State will receive a **total of \$317.7M** for the Home Energy Rebates, for a budget period no later than September 30, 2031.



Section 50121:

Home Energy Performance-Based, Whole House Rebates (Referred to as **Home Efficiency Rebates, or HER**)

Total: \$159M

Per dwelling unit incentives based on energy savings, calculated through modeled or measured energy savings



Section 50122:

High-Efficiency Electric Home Rebate Program (Referred to as **Home Electrification and Appliance Rebates, or HEAR**)

Total: \$158.4M

Prescriptive per dwelling unit incentives based on eligible measure categories

HEAR Eligible Measures and Rebate Amounts

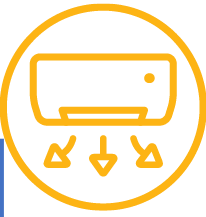

Measure Type	Rebate Amount Per Housing Unit	80-150% AMI	<80% AMI
Heat Pump Water Heater	\$1,750	Up to 50% of qualified project cost	Up to 100% of qualified project cost
Heat Pump (heating/cooling)	\$8,000		
Induction Cooking Appliance	\$840		
Heat Pump Clothes Dryer	\$840		
Electrical Service Upgrade	\$4,000		
Electrical Wiring Upgrade	\$2,500		
Insulation, Air Sealing, Ventilation	\$1,600		
Maximum per unit	\$14,000		

Multifamily buildings require “not less than 50%” of households to meet the eligible income level to qualify

Additional installer incentive up to \$500 for Disadvantaged Community and single or multiple measures installed

Appliances, systems, equipment, infrastructure, and components must be ENERGY STAR certified if applicable

HER Rebate Amount 5+ Unit Buildings



Energy Savings (whole building)	Income >80% AMI		Income <80% AMI	
20-34% Modeled	\$2,000/ unit (max \$200,000)	Up to 50% of total project cost	\$4,000/unit	Up to 80% of total project cost
35%+ Modeled	\$4,000/unit (max \$400,000)		\$8,000/unit	

Multifamily buildings require “not less than 50%” of households to meet the eligible income level to qualify

Additional installer incentive up to \$200 for installations in Disadvantaged Community

HEAR & HER Considerations for Multifamily Programs

To be eligible for HEAR/HER MF incentives, NYSERDA anticipates that the following criteria should be met:

- **Funds available statewide** regardless of SBC status, provided they meet the income threshold
- **Scope considerations** – the heat pump should cover at least 50% of the building's heating load. A project's scope of work is expected to be holistic of the full residential space of the building.
- **Customers** – customers for multifamily programs will be building owners or property management companies
- **Mixed Use Buildings** – both HEAR and HER require the upgrades service the residential portion of a mixed use building and have rules against commercial spaces being served
- Ensure work supported does not create an “**unacceptable risk of raising utility bills**” when electrifying heating, per DOE requirements

Where are We Right Now

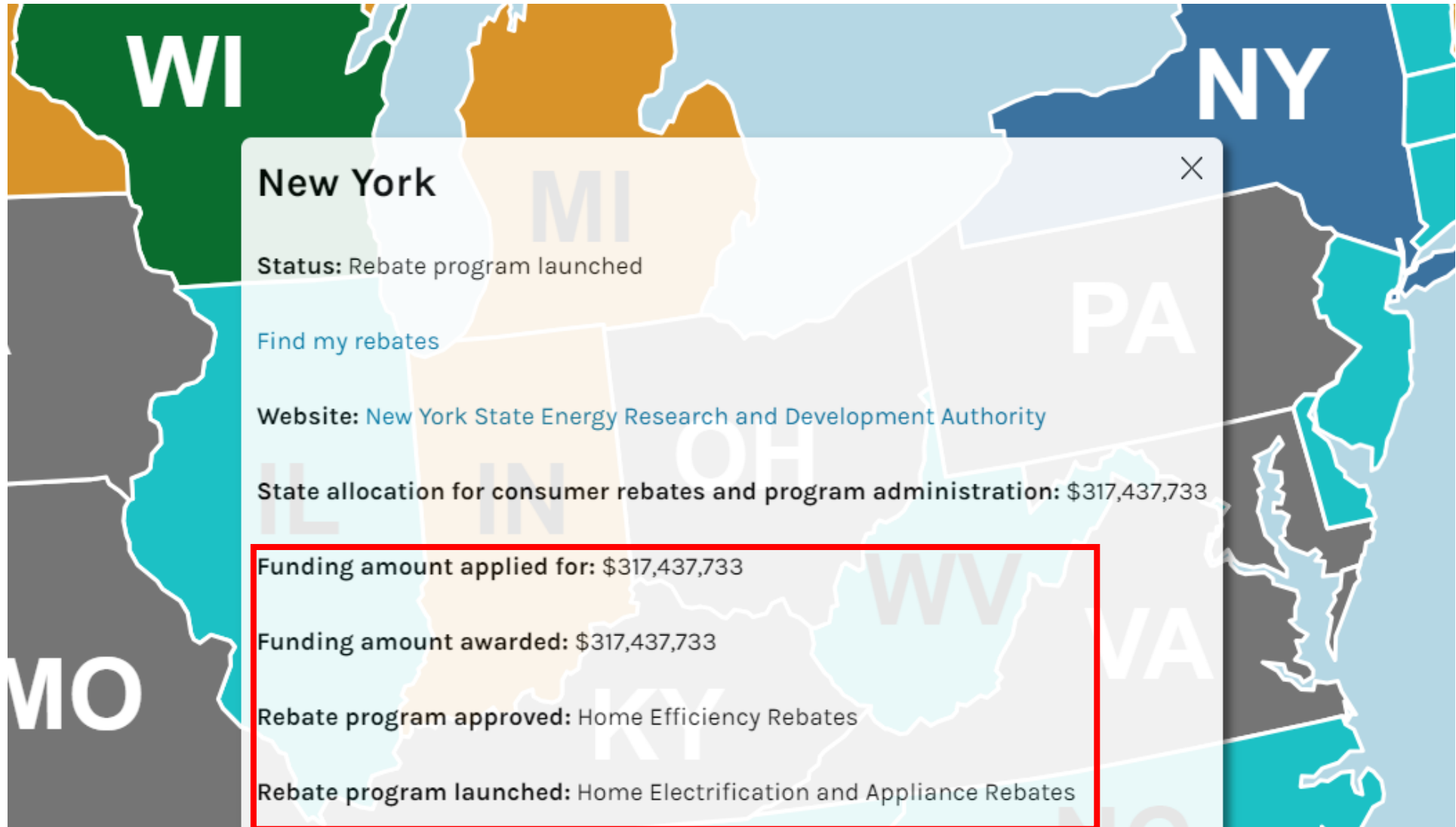

DOE Home Energy Rebate Tracker - <https://www.energy.gov/save/rebates>

Multifamily residential (5 units+) programs

- > Expected to be in market early 2025
- > HEAR/HER funds for multifamily buildings will be provided through standalone programs that leverage tools and resources from previous programs and covered under an overarching Multifamily offering, **Multifamily Residential Energy Pathways (MREP)**
- > MREP will be comprised of separate multifamily programs but with unified elements, where applicable: Common Application, Incentive Award Letter, Terms & Conditions
- > Participating contractors will be eligible to participate in this new offering

Multifamily Residential Energy Pathways

HEAR

HER

Future
Multifamily
Programs

IRA Home Energy Rebates

MREP Participating Contractor Network

New Contractor Network will be composed of various service categories

Service Categories	Service Subcategories
Energy Assessor	Energy Assessor
Clean Heat Installer	ASHP Installer
	GSHP Installer
	Direct Exchange GSHP Installer
Participating Contractor Installer	Electricians
	Plumbers
	General Contractors
	Insulators – Shell/Envelope
	Insulators - Window/Insulated Panel/Storm Window

Network Comparison

	MF Building Solutions Network	MREP Participating Contractor Network
Network Composition	Energy Consultants	Energy Consultants, Clean Heat Installers, Participating Contractor Installers
Participating Programs	MPP, LCP, AMEEP, IPNA	Current MF programs and future IRA programs
Application Submission	Email requested materials and complete Excel app workbook	Application in Salesforce and materials can be uploaded to Salesforce
Services Offered	Asked for energy consulting firm services (e.g., energy modeling, utility bill analysis)	Expanded to implementation of various building systems
Contracted Work	Limited to Participating Programs	Participating Programs and technical assistance through mini-bids (RFQL solicitation)

Contractor Application

Application will be available in Salesforce starting 10/9/24

- > **Full Application** – Similar to the MF Building Solutions Network
- > **Shortened Application** – Does not require case studies, customer references, technical expertise documentation
 - > **Eligibility** - Providers in good standing that joined one of the eligible networks in past 3 years or had a project complete construction in MPP, AMEEP, WAP since then are eligible
 - **Eligible networks**
 - MF Building Solutions Network
 - Comfort Home Contractor
 - EmPower+ Contractor
 - FlexTech Consultant
 - NYS Clean Heat Participating Contractor
 - AMEEP Participating Contractor
 - WAP Subgrantees
 - HPD Pre-Qualified Vendor

Next Steps

The new participating contractor webpage will be launched by the end of September. Webpage will include updated Program Manual and link to PON.

Webinar on how to apply will be conducted on Monday, October 28th.

- Email with webinar link is forthcoming
- IRA MF marketing materials are being developed

New application will go live 10/9.

**Any questions on the process, email
mrepnetwork@nyserda.ny.gov**

Transition

MREP Participating Contractor Network will replace the MF Building Solutions Network

Program Announcement

Effective August 23, 2024, NYSERDA will no longer accept new applications to the Multifamily Building Solutions Network to allow for transition to a new Multifamily Contractor Network anticipating to launch later this year. For information about the new network contact mfbuildingsolutions@nyserda.ny.gov.

8/23/24:

MFBSN
Application
Closed

End of Sep '24:

Launch of new
Contractor
webpage

2/28/25:

Expiration of
Shortened
Application for
MFBSN

9/11/24:

MFBSN
Webinar

10/9/24:

Salesforce
Application
Training

~3/3/25:

Launch of
MREP
Programs

New Heat Pump Technology Presentation



PWHP Product Overview
Clean Heat For All Challenge

Midea America Research Center
Louisville, KY



Who is Midea? - GLOBAL COMPANY

IN HOME APPLIANCES AND AIR CONDITIONING

- Beginning with a team of 24 people and \$800 in 1968, Midea has grown to become a global multi-billion dollar company with over 166,000 employees worldwide
- Midea believes in providing surprisingly-friendly solutions by adopting a consumer-centric and problem-solving approach while constantly exploring and inventing for the future changing demands of our consumers

[Midea Group](#)

[Midea Smart Home](#)

2022 >53 B USD Total Revenue	2022 >55 B USD Market Cap	2022 166k Employees	Ratings A/A3/A S&P/Moody's/Fitch
--	---	----------------------------------	---



278

2023 Fortune
Global 500



199

2023 Forbes
Global 2000



198

Brand Finance 2023
Top 500
Most Valuable Brands

MIDEA

WIDE PORTFOLIO OF BUSINESSES AND BRANDS - VERTICAL INTEGRATION IN APPLIANCES AND ROOM AIR

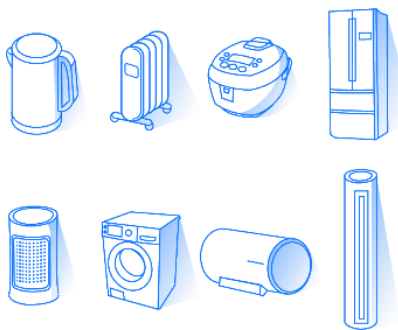

Consumer Appliances

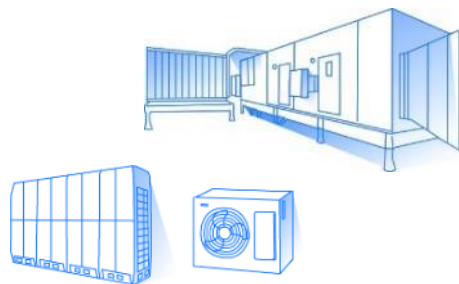

Air Conditioning

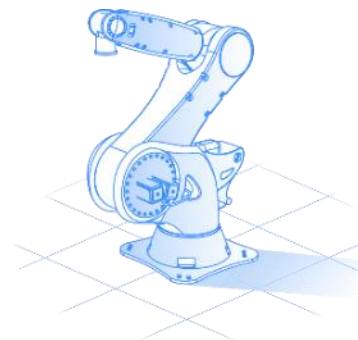

Robotics & Automation

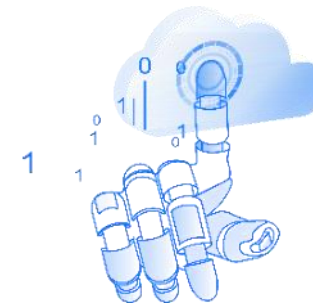

Components & Technology



Who is MARC? - Midea America Research Center

Parsippany, NJ and Louisville, KY

- Midea America Locations
 - MAC (HQ) – Parsippany NJ
 - Sales, Finance, Marketing
 - Distribution Center – Bath, PA
 - HVAC Showroom – New York
 - MARC – Louisville, KY
 - R&D
 - Average Industry Experience: 21 years
- Product Development Teams
 - Cooking
 - Dishwasher
 - Laundry
 - Refrigeration
 - Residential A/C
 - Small Appliances
 - Hot Water Heater
 - Innovation
 - Consumer Insights



Midea America Research Center - MARC

Louisville, KY



WIRELESS POWER

CONSORTIUM



AHR | 2024 | INNOVATION AWARDS

WINNER

Sustainable Solutions



Startup with the backing of the world's largest appliance manufacturer.

NYPA Clean Heat for All Challenge – Lessons Learned

- “Lean-Startup” or IndieGoGo Campaign at it’s Finest
 - Granted opportunity to place products into consumers’ hands to quickly identify areas of advancement.
 - Gave us direct line of sight to consumers’ needs based on their usage and “live data.”
 - Made necessary changes to improve the overall product.
 - Encouraged flexibility and transparency during product development.
- New Technology Development
 - The Clean Heat for All Challenge Specs granted Midea the chance to take-on new engineering opportunities.
 - Promoted Midea as technology leader and, as a result, has generated new opportunities as result.
 - Internally, for Midea Global, it has further proven the benefits of having local experts.
- Product Development Improvements
 - Improved overall efficiency creating a true 24 hr design cycle.
 - Allowed enhanced focus for problem solving.
 - Increased customer awareness

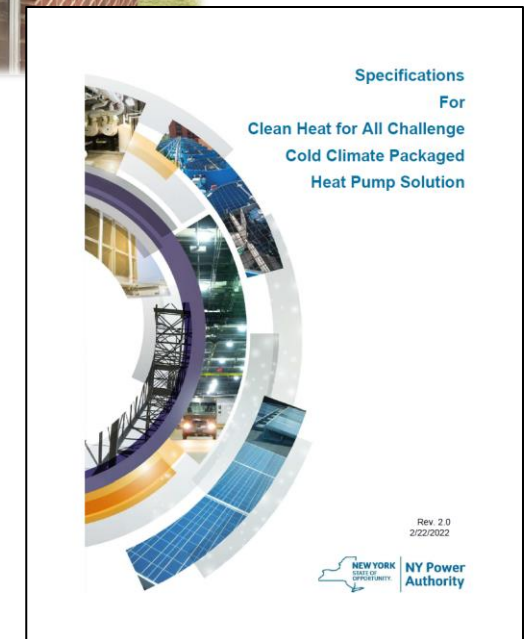

Midea PWHP - Overview



- 9,000 BTU/hr Heating and Cooling Performance
- DIY Installation
 - No refrigerant line connections
 - No new electrical needed
 - Installation Bracket Included
- Variable Speed Compressor w/Vapor Injection
- R32 Refrigerant
- Self Contained Condensate Management
- Connected Models
 - Wireless BACnet Capable Model
 - Wi-Fi Model
- DOE & NRCAN Certified
- Certified to UL 60335-2-40 3rd Edition

Specification

	Outdoor Condition	Capacity (BTU/hr)	Efficiency
Cooling Mode	95°F (35°C)	9010	11.81 EER
Heating Mode	47°F (8.3°C)	9000	4.0 COP
	17°F (-8.3°C)	9000	2.42 COP
	5°F (-15°C)	9000	2.0 COP
Min Temp	-13°F (-25°C)	5050	1.41 COP
CEER		16.2	
SEER2		19	
HSPF2		10.12	
Indoor Sound Pressure Level	High	Low	Silent
	51 dB(A)	43 dB(A)	29 dB(A)
Unit Weight		130 lbs	

MIN WINDOW DIMENSIONS

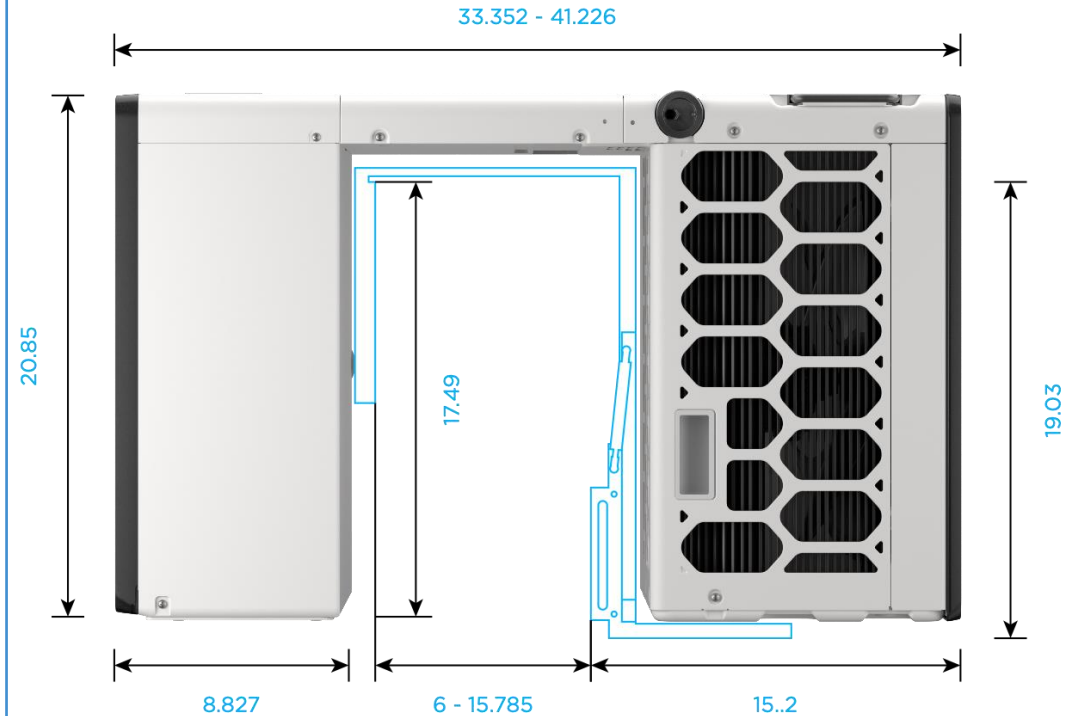
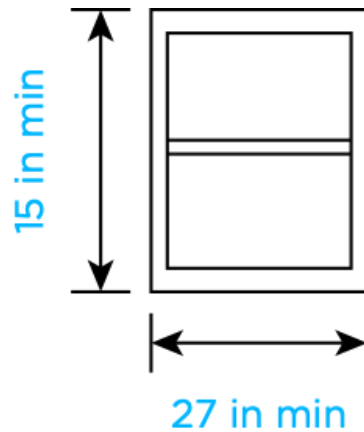

Midea PWHP - Installation

- Minimum Window Requirements
 - Hung Window Style
 - Opening Height : ~15 in
 - Opening Width : ~27 in.
- Included Installation Bracket
 - Thermal Conductivity Minimization
- Hinged Outdoor Section
- Telescoping Bridge Section
- Window Kit
 - Air Infiltration Minimization



Midea PWHP – Smart Controls - BACnet

- Wireless Mesh Network via Zigbee

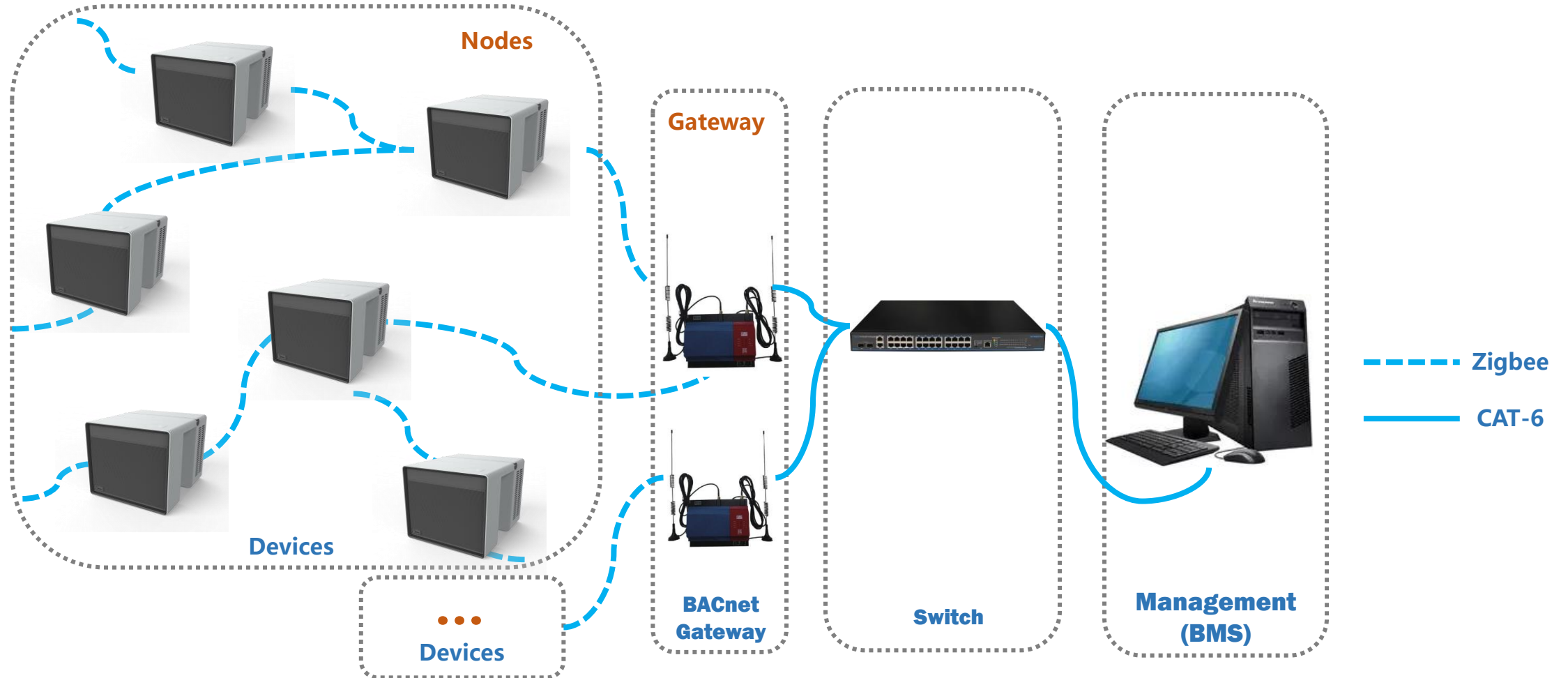

Midea PWHP – Smart Controls – Wi-Fi Models

- Midea Smart Home App
- Works with Alexa
- Works with Google Home
- IFTTT Compatible
- Scheduling & Geo-fencing Features

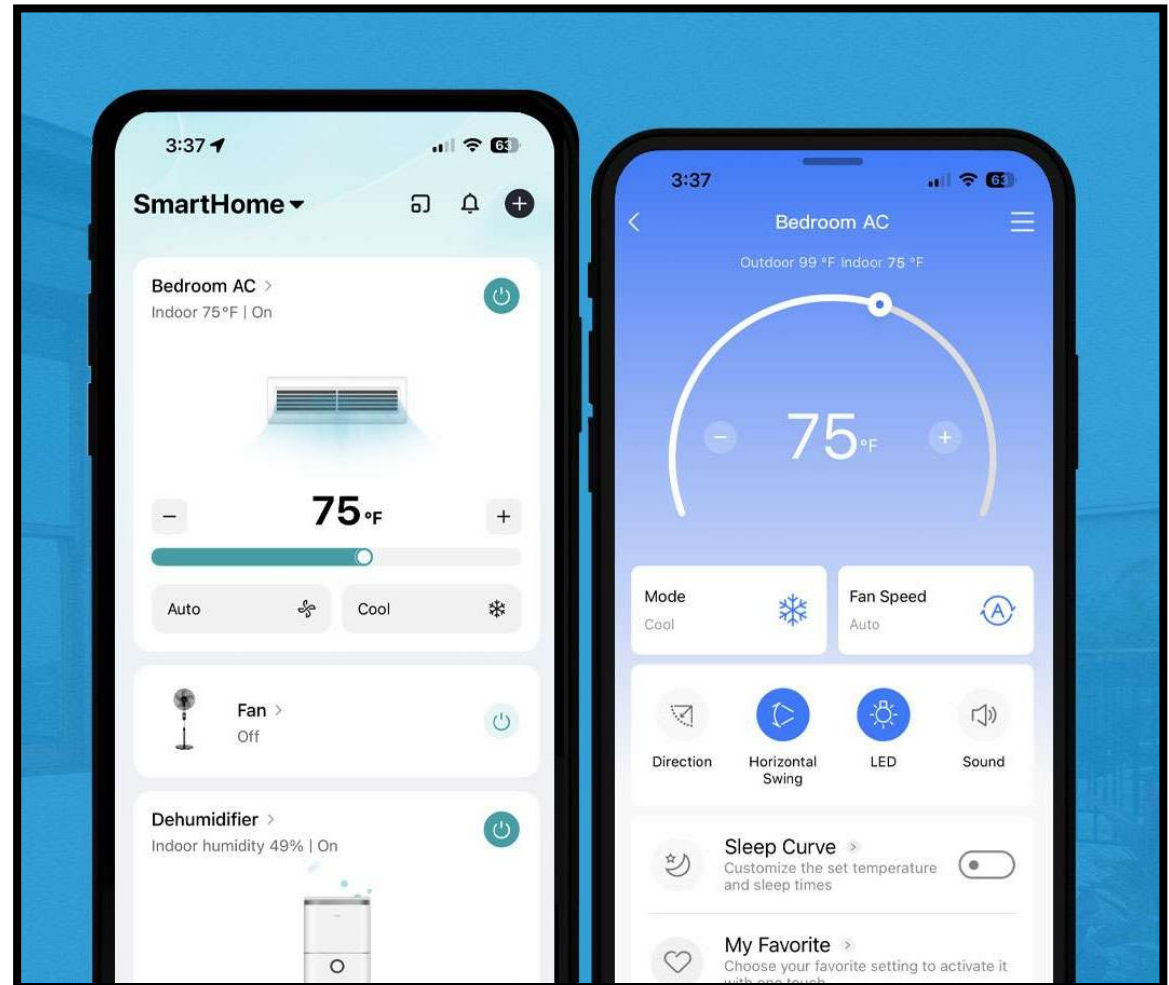

Summary

- Clean Heat for All - A Best Practice
- Creates a new Class in the Room Air Category
- Laying the foundation for future products



Midea PWHP – Condensate Management

- Self Contained Condensate System
 - Cannot freeze or drip
 - No new plumbing
- Functional @ all temperatures
- No electric resistance heaters



Efficient Heat Transfer Heat

By paralleling the refrigerant pipe to the entire condensate circulation system, the excessive heat of the refrigerant lines transfer heat to the drain pan and water line without the assistance of an electric heater.



Exclusive Heat Recovery Technology

VS



Conventional heat pump system

- No drain pan to hold the defrost water, the base can be frozen
- Formed ice could damage the fan blade while operation



Open Forum

mfbuildingsolutions@nyserda.ny.gov