



Complementary renewable heating technologies installed at Hidley Farm



Customer
Hidley Farm

Location
North Greenbush
(Rensselaer County)

Equipment
Econoburn boiler

Type of fuel
Wood

Installation date
2008

Left: Hidley Farm. **Top right:** Econoburn boiler. **Bottom right:** Cordwood storage. (Photo credits: Dick Gibbs)

Hidley Farm is situated on 130 partially wooded acres in North Greenbush, a town in Upstate New York’s Capital Region. The original farmhouse was built circa 1790. After additions and renovations, it is now about 4,000 square feet. During the renovation process, the homeowners implemented many energy-saving strategies such as airsealing, extensively insulating the attic and exterior of the house, replacing all 50 windows with low-e glass, and replacing all doors.

In 2008, a high-efficiency, 200,000 Btu/hr Econoburn cordwood, two-stage wood gasification boiler was installed in an outbuilding with wood storage. In 2009, a solar thermal, hot-water system was installed. Four 4-foot-by-8-foot flat plate collector panels provide additional energy to meet space heating and domestic hot water loads. An antifreeze solution is circulated from the heating systems through insulated, underground pipes to the home’s heating network, which includes a 1,250-gallon thermal storage tank in the basement (see diagram on back). The water within this thermal storage tank is heated by passing the antifreeze solution through three copper-coil heat exchangers. The tank has a nominal operating temperature range of 120-170 °F, which provides approximately 500,000 Btu of dynamic thermal storage. The heating system also utilizes the old oil boiler as backup and includes an electric water heater to supplement domestic hot water production. The heating and hot water loads are primarily met by the solar thermal system and cordwood boiler.

Challenge

Historically, a major challenge has been the availability of cordwood heating appliances that burn wood efficiently and cleanly. Cordwood boilers also

The homeowners wanted to use wood harvested from forest stand improvement activities, eliminate boiler operation from spring through fall, and minimize combustion generated air emissions. Integrating the Econoburn cordwood two-stage gasification boiler with thermal storage and a solar-thermal system maximized efficiency and reduced emissions.

require the owner to load the wood and start the fire. Although some people may find this process undesirable, others take satisfaction in cutting, splitting, and handling the fuel for their home heating system.

Solution

Staged combustion cordwood boilers are a common design in Europe, and are now emerging in the United States. These cordwood boilers are able to achieve 70% thermal efficiency on an annual basis, which is far greater than their single-chamber counterparts. In the first stage, firewood is combusted at relatively low temperatures under oxygen-starved conditions in order to off-gas volatile compounds. These gases are injected into a refractory-lined secondary chamber under oxygen-rich conditions where high temperatures, adequate residence time, and turbulent mixing promote complete combustion. Integrating an advanced cordwood boiler with thermal storage is essential and maximizes performance. This combination optimizes performance of the cordwood boiler due to the nearly steady-state operation and drastic reduction in cycling, allowing it to achieve performance levels comparable to oil. Installing thermal storage with a cordwood boiler facilitates the addition of a solar thermal heating system. Both the cordwood boiler and the solar thermal heating system can share the thermal storage tank.

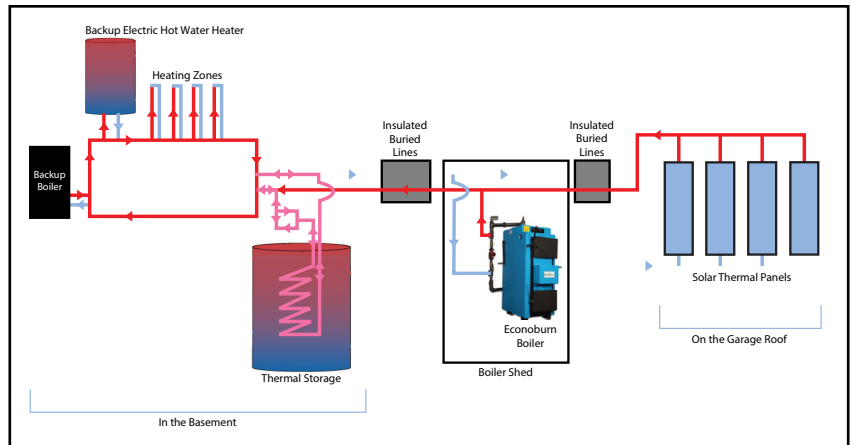

A simplified schematic of the heating system at the Hidley Farm. The heating zones take hot water to radiators throughout the farmhouse, and a radiant floor in the renovated kitchen.

At this location, to prevent freezing pipes and other damage if the homeowners were to leave for an extended period, the oil boiler kicks on when the thermal storage drops below 100 °F. The electric water heater serves a backup role. It is used primarily for summer operation when the solar output is too low (such as during an extended cloudy period) or when hot water demand is high (such as hosting many grandkids).

Results

In the first year of operation, all heat demands including domestic hot water were met by combusting about seven full cords of wood that was split and properly dried (<20% moisture content). Proper seasoning of the wood improves efficiency. Wood should be cut, split, stacked, and stored under cover for about two years to be properly seasoned. Without the insulation and other energy saving improvements, the boilers would have operated more often.

The homeowners can leave for up to three days during the winter, and rely entirely on energy drawn from the thermal-storage tank to keep the home heated. The homeowners did not have to fire either the cordwood or oil boilers from April until late September of 2010 due to the addition of the solar thermal system. The thermal storage temperature was in the range of 110-130 °F from the solar panels alone throughout the spring and summer of 2010.

Get started

Visit nyscrda.ny.gov/renewable-heat-ny or call **1-866-NYSERDA** to learn how you can reduce your energy consumption and costs.

Renewable Heat NY is a statewide program that targets areas without access to natural gas and is helping to increase the efficiency of advanced heating technologies that use wood; develop infrastructure surrounding the industry; cut consumer costs; and reduce wood smoke and carbon monoxide emissions.

NYSERDA, a public benefit corporation, offers objective information and analysis, innovative programs, technical expertise, and support to help New Yorkers increase energy efficiency, save money, use renewable energy, and reduce reliance on fossil fuels. NYSERDA professionals work to protect the environment and create clean energy jobs. NYSERDA has been developing partnerships to advance innovative energy solutions in New York State since 1975. To learn more about NYSERDA's programs, visit nyscrda.ny.gov or follow us on Twitter, Facebook, YouTube, or Instagram.

