

New York State Energy Storage Study

Final Report | Report Number 20-34 | November 2020



NYSERDA's Promise to New Yorkers:

NYSERDA provides resources, expertise, and objective information so New Yorkers can make confident, informed energy decisions.

Mission Statement:

Advance innovative energy solutions in ways that improve New York's economy and environment.

Vision Statement:

Serve as a catalyst – advancing energy innovation, technology, and investment; transforming New York's economy; and empowering people to choose clean and efficient energy as part of their everyday lives.

New York State Energy Storage Study

Final Report

Prepared for:

New York State Energy Research and Development Authority

Albany, NY

Sumit Bose
Senior Project Manager

Prepared by:

Quanta Technology, LLC.

Raleigh, NC

Hugo Bashualdo P. Engineer
Henry Chao, Ph.D.
Ralph Masiello, Ph.D.
Farnaz Farzan, Ph.D.
Elli Ntakou, Ph.D.
Project Managers

Notice

This report was prepared by Quanta Technology, LLC, in the course of performing work contracted for and sponsored by the New York State Energy Research and Development Authority (NYSERDA) and Central Hudson Gas & Electric (CHG&E) (hereafter the "Sponsors"). The opinions expressed in this report do not necessarily reflect those of the Sponsors or the State of New York, and reference to any specific product, service, process, or method does not constitute an implied or expressed recommendation or endorsement of it. Further, the Sponsors, the State of New York, and the contractor make no warranties or representations, expressed or implied, as to the fitness for a particular purpose or merchantability of any product, apparatus, or service, or the usefulness, completeness, or accuracy of any processes, methods, or other information contained, described, disclosed, or referred to in this report. The Sponsors, the State of New York, and the contractor make no representation that the use of any product, apparatus, process, method, or other information will not infringe privately owned rights and will assume no liability for any loss, injury, or damage resulting from, or occurring in connection with, the use of the information contained, described, disclosed, or referred to in this report.

NYSERDA makes every effort to provide accurate information about copyright owners and related matters in the reports we publish. Contractors are responsible for determining and satisfying copyright or other use restrictions regarding the content of the reports that they write, in compliance with NYSERDA's policies and federal law. If you are the copyright owner and believe a NYSERDA report has not properly attributed your work to you or has used it without permission, please email print@nyserda.ny.gov

Information contained in this document, such as web page addresses, are current at the time of publication.

Preferred Citation

New York State Energy Research and Development Authority (NYSERDA). 2020. "New York State Energy Storage Study," Report Number 20-34. Prepared by Quanta Technology, LLC, Raleigh, NC. nyserda.ny.gov/publications

Abstract

The New York State Climate Leadership and Community Protection Act (CLCPA) requires the State to achieve a carbon-free electricity system by 2040. In this move to decarbonize the electric power industry, the CLCPA calls for the deployment of 3,000 megawatts (MW) of energy storage by 2030. As one of the leading markets for energy storage development in the U.S., New York State has developed the New York State Energy Storage Study that documents a procedure for planning and evaluating energy storage system (ESS) applications in the electric utility industry. The described procedures and use cases found in this report can be used by utility planners, ESS developers, lenders, and investors in developing ESS solutions. Energy storage systems are a key building block for achieving the 100% clean electricity system of the future. Therefore, a consistent and practical study process is important for assessing the economic viability of ESS projects. The study thoroughly explored and developed a time-series analysis procedure that includes ESS siting and sizing, application staking, and benefit-cost analysis, together with the data required to perform the analyses.

Keywords

energy storage system (ESS), carbon-free, sub-transmission ESS use case, distribution ESS use case, ESS planning requirements, ESS sizing, ESS siting, ESS BCA, PV penetration, reliability enhancement, capacity deferral

Acknowledgments

The development of this report was the result of significant time and input from several New York State agencies and electric utilities. At a minimum, Quanta Technology would like to thank Sumit Bose and Anthony Abate of New York State Energy Research and Development Authority for their guidance and project management, along with the inputs and efforts led by Paul Haering, John Borchert, Stephanie Palmer, Richard Wright, Harold Turner, and their team at Central Hudson Gas & Electric to keep this important joint research effort practical and meaningful within the electric utility planning and operations domain.

Table of Contents

Notice	ii
Preferred Citation	ii
Abstract	iii
Keywords	iii
Acknowledgments	iii
List of Figures	vii
List of Tables	ix
Acronyms and Abbreviations	x
Executive Summary	ES_1
1 Use Case	1
1.1 Introduction.....	1
1.2 New York State Policy Landscape Climate Leadership and Community Protection Act.....	3
1.3 Distribution System Use Cases Description.....	4
1.3.1 Capacity Deferral.....	4
1.3.1.1 Technical Challenges and Role of Energy Storage Systems.....	4
1.3.1.2 Planning Requirements.....	6
1.3.2 Reliability Improvement.....	7
1.3.2.1 Technical Challenges and Role of Energy Storage Systems.....	8
1.3.2.2 Planning Requirements.....	10
1.3.3 Mitigation of Local Impacts of Renewable Integration.....	11
1.3.3.1 Technical Challenges and the Role of Energy Storage Systems.....	11
1.3.3.2 Planning Requirements.....	14
1.4 Transmission System Use Cases Description.....	15
1.4.1 Mitigation of Local Impact of Renewable Integration.....	15
1.4.1.1 Technical Challenges and Role of Energy Storage System.....	15
1.4.1.2 Planning Requirements.....	16
1.4.2 Management of Congestion.....	17
1.4.2.1 Technical Challenges and Role of Energy Storage System.....	17
1.4.2.2 Planning Requirements.....	19
1.4.3 Capacity Deferral.....	19
1.4.3.1 Technical Challenges and Role of Energy Storage System.....	19
1.4.3.2 Planning Requirements.....	19
1.5 Bulk Market Participation.....	20

1.6	Energy Storage System Ownership and Operations Models	22
2	System Characterization	24
2.1	Introduction	24
2.2	Distribution System	25
2.2.1	Capacity Deferral.....	25
2.2.2	Reliability Improvement.....	27
2.2.2.1	First Screening Process.....	29
2.2.2.2	Second Screening Process.....	30
2.2.3	Renewable Integration	30
2.3	Transmission System	31
2.3.1	Mitigation of Local Impact of Renewable Integration.....	31
2.3.2	Management of Congestion	32
2.3.3	Capacity Deferral at Sub-transmission System.....	33
3	Siting and Sizing.....	34
3.1	Introduction	34
3.2	Distribution System Applications.....	34
3.2.1	Peak Shaving	34
3.2.2	Reliability Improvement.....	37
3.2.3	Mitigation of Local Impacts of Renewable Integration.....	40
3.3	Transmission and Sub-transmission System Applications.....	41
4	Stacked Applications Methodology.....	43
4.1	T&D Capacity Deferral and Market Participation	44
4.2	T&D Reliability and Market Participation	45
5	Benefit-Cost Analysis Methodology	47
6	Data Requirements	51
6.1	Energy Storage System Siting and Sizing: Sub-transmission Use Cases.....	51
6.2	Energy Storage System Siting and Sizing: Distribution Use Cases.....	51
6.3	Non-Energy Storage System Mitigation Solutions	52
6.4	Stacked Applications	52
7	Distribution System Applications Case: Central Hudson & Electric (CHG&E).....	53
7.1	Capacity Deferral	53
7.1.1	Input Data and Assumptions.....	53
7.1.2	Data Cleaning and Conditioning.....	54
7.1.3	Screening Process	55
7.1.4	Energy ESS Siting and Sizing.....	56

7.1.5	Benefit-Cost Analysis.....	58
7.2	Reliability Improvement.....	61
7.2.1	Input Data and Assumptions.....	61
7.2.2	First Screening Process.....	62
7.2.3	Second Screening Process.....	63
7.2.4	Energy Storage System Siting and Sizing.....	63
7.2.5	Benefit-Cost Analysis.....	65
7.3	Renewable Integration.....	66
7.3.1	Input Data and Assumptions.....	66
7.3.2	Screening Process.....	67
7.3.3	Energy Storage System Siting and Sizing.....	67
7.3.4	Benefit-Cost Analysis.....	68
8	Transmission System Applications Case: Central Hudson Gas & Electric.....	70
8.1	Mitigation of Local Impact of Renewable Integration.....	70
8.1.1	Input Data and Assumptions.....	70
8.1.2	Screening Process.....	70
8.1.3	Energy Storage Siting.....	73
8.1.4	Energy Storage Sizing.....	73
8.1.5	Benefit-Cost Analysis.....	74
8.2	Management of Load and Congestion Relief.....	75
8.2.1	Input Data and Assumptions.....	75
8.2.2	Screening Process.....	75
8.2.3	Energy Storage Siting.....	80
8.2.4	Energy Storage Sizing.....	80
8.2.5	Benefit-Cost Analysis.....	81
8.3	Capacity Deferral at Sub-transmission System.....	82
8.3.1	Input Data and Assumptions.....	82
8.3.2	Screening Process.....	83
8.3.3	Energy Storage Siting.....	83
8.3.4	Energy Storage Sizing.....	83
8.3.5	Benefit-Cost Analysis.....	85
9	References.....	87
	Endnotes.....	EN-1

List of Figures

Figure 1. Example Energy Storage System Application for Capacity Deferral	6
Figure 2. Energy Storage System Sizing for Reliability Enhancement.....	10
Figure 3. Energy Storage System Application for Photovoltaic Smoothing	12
Figure 4. Energy Storage System Application for Backfeed Prevention.....	14
Figure 5. Networked Sub-transmission System Serving Six Loads	16
Figure 6. Demonstration of Use of Energy Storage System for N-1 Congestion Relief.....	18
Figure 7. Overall Screening and Transmission System Evaluation Process	25
Figure 8. Overall Screening and Distribution System Evaluation Process	25
Figure 9. Screening Process: Infrastructure and Capacity Support	27
Figure 10. Two-Stage Screening Process: Reliability Enhancement	28
Figure 11. Energy Storage System Located Where Overloaded Section Ends (Downstream of SUB).....	34
Figure 12. Energy Storage System Located Just Downstream of the Overloaded Section.....	35
Figure 13. Energy Storage System Located Close to the Heavily Loaded Feeder Section/Branch.....	35
Figure 14. Energy Storage System Capacity Estimation (Megawatt and Megawatt-Hour)—Graphical Process	37
Figure 15. Line Section Experiencing Multiple Power Outages at the Middle of the Feeder	38
Figure 16. Line Section Experiencing Multiple Power Outages at the Feeder Head Section	38
Figure 17. Sub-transmission Radial Line Section Experiencing Multiple Power Outages	39
Figure 18. Energy Storage System Located at the Targeted Feeder Section	39
Figure 19. Energy Storage System Sizing (Red Bars) for Reliability Enhancement.....	40
Figure 20. Energy Storage System Sizing for Renewable Integration	41
Figure 21. Day-Ahead Energy Market Participation.....	45
Figure 22. Reliability and Market Participation.....	46
Figure 23. Market Benefit of Energy Storage System.....	50
Figure 24. Various Revenue Streams of Energy Storage System	50
Figure 25. BR 4091 Time-Series with and without Data Cleaning	55
Figure 26. Selected Feeders (Values in MW)—Tier 3 in 2023 (Peak > 100% of Normal Rating) ^a	56
Figure 27. Hourly Load Profiles for Feeder NC_8051.....	57
Figure 28. Hours NC_8051 Exceeds Design Rating.....	57
Figure 29. Revenue Requirement for Upfront Energy Storage System Installation Compared to Transmission and Distribution Upgrade Costs.....	60
Figure 30. Pretax Cash Flow for Upfront Energy Storage System Installation Compared to Transmission and Distribution Upgrade Costs.....	61
Figure 31. Representation of Feeder WS-3012 in a Single Line Diagram.....	63
Figure 32. Peak-Day Load in 2018.....	64
Figure 33. Energy Storage System Energy Requirement on Peak Day.....	64
Figure 34. Revenue Requirement for Upfront Energy Storage System Installation Compared to Transmission and Distribution Upgrade Costs.....	65

Figure 35. Pretax Cash Flow for Upfront Energy Storage System Installation Compared to Transmission and Distribution Upgrade Costs.....	66
Figure 36. Energy Storage System Hourly Operation to Mitigate Overvoltage Violation with Increased PV Levels.....	68
Figure 37. Revenue Requirement for Upfront Energy Storage System Installation Compared to Transmission and Distribution Upgrade Costs.....	69
Figure 38. Pretax Cash Flow for Upfront Energy Storage System Installation Compared to Transmission and Distribution Upgrade Costs.....	69
Figure 39. 70-MW Solar PV Power Output Yearly Profile—Greene County	71
Figure 40. 20-MW Solar PV Power Output Yearly Profile—Sunset Hill Solar, Albany County ...	72
Figure 41. 40-MW Solar PV Power Output Yearly Profile—Ulster County	72
Figure 42. 2018 Zone G Yearly Load Profile	73
Figure 43. Revenue Requirement (Ratepayer) and Pretax Cash (Utility) Flow: Coxsackie 69kV.....	74
Figure 44. HQ Interface Flow Profile	76
Figure 45. Ontario Interface Flow Profile	77
Figure 46. PJM-NYISO Interface Flow Profile	77
Figure 47. ISONE-NYISO Interface Flow Profile	78
Figure 48. Sum of CSC + Norwalk + Neptune + VFT + HTPInterface Flow Profiles	78
Figure 49. Revenue Requirement (Ratepayer) and Pretax Cash (Utility) Flow—Hurley	82
Figure 50. Minimum Backup, Outage at Saugerties—Woodstock Line, ESS at Woodstock, 10 MW/250 MWh.....	83
Figure 51. Minimum Backup, Outage at Saugerties—Woodstock Line, ESS at Woodstock, 17.5 MW/250 MWh.....	84
Figure 52. Minimum Backup, Outage at Saugerties—Woodstock Line, ESS at Woodstock, 17.5 MW/150 MWh.....	84
Figure 53. Minimum Backup, Outage at Saugerties—Woodstock line, Energy Storage System at Woodstock, 17.5 MW/350 MWh.....	85
Figure 54. Revenue Requirement (Ratepayer) and Pretax Cash (Utility) Flow, 17.5 MW/250 MWh.....	86

List of Tables

Table 1. Summary of Capacity Deferral Application	5
Table 2. Summary of Outage Management Improvement Applications	8
Table 3. Summary of Renewable Integration Applications.....	13
Table 4. Comparison of Front-of-the-Meter Market Participation	21
Table 5. Capacity Deferral Tiers Definition	27
Table 6. Market Products that Energy Storage System Can Provide.....	43
Table 7. Energy Storage System Parameters Needed for Market Participation Revenue Calculation and Suggested Values.....	44
Table 8. Cash Flow Items for Utility Pretax Cash Flow Perspective.....	48
Table 9. Cash Flow Items for Revenue Requirement Perspective.....	49
Table 10. Feeder Annual Load-Growth Assignment.....	54
Table 11. Energy Storage System Annual Net Benefits	58
Table 12. ESS Cost Assumptions	59
Table 13. Financial Parameters	59
Table 14. Break-Even Cost at Different Mode of Operation (Ratepayer).....	60
Table 15. Break-Even Cost at Different Mode of Operation (Utility).....	61
Table 16. Ranking of Feeders Based on Reliability Performance Index	62
Table 17. Energy Storage System Annual Net Benefit	65
Table 18. Break-Even Cost at Different Mode of Operation (Ratepayer).....	65
Table 19. Break-Even Cost at Different Mode of Operation (Utility).....	66
Table 20. Energy Storage System Annual Net Benefit	68
Table 21. Break-Even Cost at Different Mode of Operation (Ratepayer).....	69
Table 22. Break-Even Cost at Different Mode of Operation (Utility).....	69
Table 23. Solar PV interconnection Capacity and Location	71
Table 24. Annual Energy (MWh) per Zone	75
Table 25. Interface Total Annual Power Flow Result (Year 2017)	76
Table 26. Contingency-Monitored Element Pairs Modeled.....	79
Table 27. Top Five Discharging Sites for Congestion Relief Use Case	80
Table 28. Battery Sizes for Different Levels of Congestion Mitigation.....	81

Acronyms and Abbreviations

BCA	Benefit-cost analysis
CD	Capacity deferral
CDA	Capacity deferral and arbitrage
CDAAM	Capacity deferral, arbitrage, and ancillary service market
CHG&E	Central Hudson Gas & Electric
ELR	Energy limited resources
ESS	energy storage system
FTM	Front-of-the-meter
ISO	Independent system operator
kWh	kilowatt-hours
LESR	Limited energy ESS resources
LMP	Locational Marginal Pricing
LODF	Line outage distribution factor
LTC	Load-tap changer
MW	megawatts
NERC	North American Electric Reliability Corporation
NWA	Non-wires alternative
NYISO	New York Independent System Operator
NYS	New York State
NYSERDA	New York State Energy Research and Development Authority
NYTO	New York Transmission Owners
OTDF	Outage transfer distribution factor
PTDF	Power transfer distribution factor
RPI	Reliability performance index
RTO	Regional transmission organization
SF	Stiffness factor
T&D	Transmission and Distribution
TSO	Transmission system operator
VAR	Volt-ampere reactive
W	watts

Executive Summary

The New York State Climate Leadership and Community Protection Act (CLCPA) requires the State to achieve a carbon-free electricity system by 2040. In this move to decarbonize the electric power industry, the CLCPA calls for the deployment of 3,000 megawatts (MW) of energy storage by 2030. Reflecting New York State's position as one of the leading markets for energy storage development in the U.S., the New York State Energy Research and Development Authority (NYSERDA) has contracted Quanta Technology to conduct a New York State Energy Storage Study to document procedures for planning and evaluating energy storage system (ESS) applications in the electric utility industry. The described procedures and use cases found in this report can be used by utility planners, ESS developers, lenders, and investors in developing ESS solutions.

Energy storage systems are a key building block for achieving a 100% clean electricity system in the future. As interest in ESSs grows, industry practitioners are seeking information and best practices built from current and past efforts. Developers need a practical method to assess the operating performance of ESSs in the electric system. An individually designed ESS may be useful in one application but inefficient in another. A better understanding of electric system operating requirements and constraints when planning ESSs allows for greater certainty that the system will perform reliably and predictably. Similarly, it is important to have a consistent and practical process for assessing the economic viability of ESS projects.

The seven case studies summarized in this report were selected based on utility needs, lessons learned from experience with other utilities around the country, and each case study's cross-sectional representation. These projects represent a range of program solutions, project siting and sizing processes, and non-wires alternative (NWA) comparisons.

During the study, Central Hudson Gas and Electric Corporation (CHG&E) and Orange and Rockland Utilities, Inc. (Orange & Rockland) noted the importance of having a deep understanding of their service territories, infrastructure design history, and grid conditions to help inform their program and ESS implementations. Various benefit-cost analysis (BCA) methodologies to evaluate NWA and other design options were considered. In all cases, the four foundational pillars were reliability, project performance under various grid operating conditions, customer expectations, and project economics.

The study developed and thoroughly explored a time-series analysis procedure that includes ESS siting and sizing, application staking (i.e., regulation, energy arbitrage, capacity support, etc.), and BCA, together with the data required to perform the analyses. The time-series methodologies discussed in the report allow system planners to assess ESS project performance, risks associated with technology limitations, and electric system operating constraints.

Electric system planning is a continual process of evaluating, monitoring, and updating—making a systematic evaluation process for ESS invaluable in the development of reliable and economically efficient ESS applications. Applying the evaluation methodology to use cases based on the CHG&E system provides confidence that the procedure presented in this report has been thoroughly assessed.

1 Use Case

1.1 Introduction

Energy storage systems (ESS) that are connected through transmission and distribution (T&D) currently have multiple identified use cases and could potentially have more in the future. While there are some existing ESS on the customer side of the electric meter, also called behind-the-meter ESS in the New York State area, this research project focuses on the use of ESS on the utility side of electric meter only, also known as front-of-the-meter (FTM) ESS. ESS applications span the functions of generation, transmission, and distribution as a market resource as well as an infrastructure asset. As the owners of the T&D assets, the New York Transmission Owners (NYTOs) are responsible for the reliable operation of the distribution systems and sub-transmission networks. This study focuses on assessing the benefits of an ESS, no matter where it is located on the utility's system. For distribution and sub-transmission systems, we discuss the following primary ESS use cases:

- **Reliability (distribution).** For reliability improvement, ESS can improve reconfiguration and post-outage restoration.
- **Capacity deferral (T&D).** Deferral of T&D investment can be achieved through peak shaving with controlled ESS charging/discharging cycles.
- **Mitigation of local impacts of renewables (T&D).** Hosting capacity improvement is separately examined for sub-transmission and distribution networks.
- **Congestion management (transmission).** Impacts of ESS devices on reducing congestion should one a single system element is lost (N-1 contingency) for improved asset utilization and deferral of sub-transmission upgrades are investigated under this use case. The benefits of ESS to the sub-transmission system can be thought of as a NWA to transmission upgrades.
- **Bulk market participation.** Identified as a secondary use case and addresses the utilization of ESS for revenue generation by participating in NYISO wholesale markets.

Energy Storage System Use Cases

Primary Use Case

1. Distribution system:
 - Capacity deferral
 - Reliability
 - Mitigation of local impacts of renewable integration
2. Transmission system:
 - Mitigation of local impacts of renewable integration
 - Management of congestion
 - Capacity deferral

Secondary Use Case

3. Bulk market participation

It should be noted that this research project focuses on ESS primarily deployed to support a function at the distribution or sub-transmission level operated by the NYTOs. The ESS may also participate as a bulk-power resource in NYISO's markets (e.g., energy, capacity, or ancillary services), alone or in aggregate, during times when the dispatch of the ESS can be coordinated in such a way as to not conflict with its designed application/services. As such, ESS can be owned/operated by an NYTO or through a contract with a third-party to operate under the NYTO's direction for primary use cases (e.g., for local reliability and infrastructure improvements, to enable greater hosting capacity for renewable generation, etc.) and can also serve as a bulk-power resource when this use is coordinated.

Discussion around each use case is organized as follows:

- Technical challenges and ESS's role
- Planning requirements

Wholesale market participation is common for both distribution- and sub-transmission-connected ESS, although providing certain market products (e.g., regulation) might be limited by the local operational constraints (e.g., voltage) of the distribution network. This research project outlines the current possibilities for revenue generation for ESS based on the NYISO market construct.

Finally, potential ESS ownership and operational models that can be adopted for each application are discussed and summarized.

1.2 New York State Policy Landscape Climate Leadership and Community Protection Act

New York State led the power industry by initiating a Reforming the Energy Vision (REV), a groundbreaking regulatory reform to provide motivation for utilities to build a clean, resilient, and affordable energy system. This effort has been further inspired by the CLCPA in 2019 when the CLCPA has come into effect. The CLCPA seeks to advance the adoption of clean energy technologies across the economy while promoting the transition to a zero-emissions power grid by 2040. Specifically, utilities are required to install 3,000 MW ESS by 2030. New York State's Green New Deal put \$350 million of investment into energy storage that includes \$280 million available now from New York State Energy Resource and Development Authority (NYSERDA) and an additional \$70 million to be allocated based on opportunities that have the greatest potential to support a self-sustaining storage market. Moreover, investor-owned utilities are required, as part of NY REV, to submit Distributed System Implementation Plans (DSIPs) and to participate in NY REV demonstration projects.

A DSIP presents a utility's plans to accommodate and encourage distributed energy resource (DER) development, distributed system operations, and all requisite information needed to detail a utility's current and expected efforts to align with NY REV mandates. DERs include ESS, demand response, and distributed generation (DG). DSIPs detail a utility's anticipated approach over a five-year horizon and are formally submitted every two years.

The goal of NY REV demonstration projects is to develop and test new business models and new technologies that can help achieve, and potentially further, the NY REV goals. The results of the NY REV demonstration projects are used to determine the viability and expandability of approaches included in the DSIPs and to inform the formulation of future DSIPs.

Utilities are already contracting ESS facilities to meet the needs of NWA use cases. The goal of this project is to establish a methodology that may be adopted statewide by utility planners and operators to assess the application of ESS to the many potential use cases needed to meet the REV goals.

1.3 Distribution System Use Cases Description

A distribution system planning process considers, among other things, the following three elements: demand growth, reliability, and cost. (Utility worker and public safety are a power utility's primary concern, but safety is outside the scope of this document.) This section focuses on the following elements: (1) providing power as demanded and (2) maintaining power quality and reliability at an acceptable price.

1.3.1 Capacity Deferral

This use case refers to the deferral of a capacity upgrade due to load growth at the distribution level utilizing annual peak shaving sustained over many years. ESS, when properly engineered, can mitigate overloads at the substation or on other feeder equipment.

1.3.1.1 Technical Challenges and Role of Energy Storage Systems

Capacity upgrades are typically and primarily driven by load growth, which has brought the forecasted peak demand on a distribution circuit or substation transformer to near the normal ratings of the substation or distribution system. ESS can be a cost-effective solution to defer distribution or sub-transmission upgrades. An ESS can inject power during anticipated peak load hours and, if sized appropriately, can address thermal-rating issues on distribution network elements (allowing for the possibility to defer system upgrades). In this role, ESS needs to be located downstream of overloaded sections of a circuit or the substation transformers so that they can serve a portion of peak demand, reducing the potential overload such that an upgrade of the equipment is no longer needed or is deferrable. In some cases, low-voltage conditions near the end of a circuit may also drive capacity upgrades, and while traditional solutions are usually more cost-effective (e.g., regulators and capacitors to support voltage), ESSs have more potential to be cost-effective when voltage issues are coupled with thermal loading issues.

Furthermore, ESS—unlike traditional system upgrades (e.g., reconductoring existing feeders, new distribution feeders, new substations, expanding existing substations)—provides a flexible alternative that can remedy overloading on an as-needed basis. Of course, in some applications, the ESS may

become a permanent asset. In today’s low load-growth environment, as experienced by many utilities, a careful analysis is required to identify the relatively small set of substations/circuits where the application is worthwhile. In some cases, additional applications and benefits (so-called stacked applications) may be important in building a positive business case for an ESS.

Table 1 summarizes applications related to capacity deferral along with the economics and required ESS capacity duration. It should be noted that capacity deferral can be combined with renewable integration and wholesale market services to maximize ESS utilization and economics. The optimal deferral period is a complex tradeoff among capital and operating costs of ESS versus traditional assets, ESS sizing against load-growth rates, ESS degradation with daily cycling, and projected cost increases (traditional assets) and decreases (batteries).

Table 1. Summary of Capacity Deferral Application

CAPACITY DEFERRAL			
Application	Economics	Duration	Remark
Capital deferral (peak shave)	May be positive for overloaded systems	Two–six hours	Substation transformer, station exit cable are targets
Energy arbitrage implicit in capacity deferral (peak shaving)	Limited, as it only occurs on peak days; however, energy arbitrage can occur daily	Capacity deferral requirement	Savings may occur and are passed to customers via true-up, etc.

Capacity deferral methodology involves overlaying load growth over future years on each studied distribution feeder, along with the feeder’s ratings, and estimating, on the one hand, the upgrade’s size and timing (see Figure 1) and, on the other hand, the proper ESS size to replace the aforementioned upgrade. For this application, the most common case studied is that of an overload at the feeder head, since the substation transformer can be one of the costliest distribution system assets. Therefore, for a substation overload, the ESS is typically located near the substation for optimal benefits, but distributed ESS installations along the feeder can also be deployed.

Figure 1. Example Energy Storage System Application for Capacity Deferral

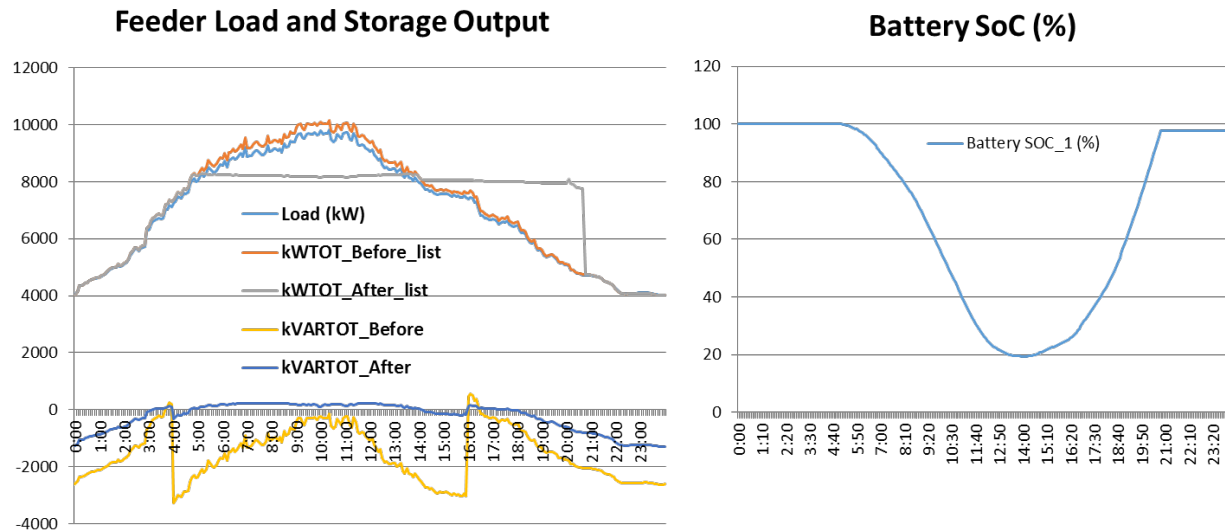

An ESS can participate in wholesale markets, but it can only do so when its participation is not in conflict with the capacity deferral use case. In other words, the capacity deferral use case takes precedence, and any market participation must be coordinated with the capacity deferral use case. The capital cost of ESS systems as projected for the year installed (and regular T&D upgrades as the baseline), as well as an ESS's operating expenses, removal costs (if applicable), incremental depreciation, and additional savings/revenue streams from peak shaving and market participation, are all considered and fed into a benefit-cost analysis (BCA) to fully estimate benefits and costs of ESS as a solution for capacity deferral. The BCA is performed from a ratepayer perspective, as well as the investor perspective, whether the investor is the utility or a third party.

1.3.1.2 Planning Requirements

Most utilities have a defined planning period of five to ten years. Shorter-term planning identifies specific projects such as those required by firm interconnection requests within a 60-month horizon or the need to remediate operational problems (e.g., updating protection coordination) as well as safety, power quality, condition-based evaluations, and reliability improvement requirements. Larger projects such as new substations are typically part of longer-term planning driven by spatial load forecasting and macroeconomic drivers. This process involves the engagement of various teams such as economic development, operations, asset management, engineering, and maintenance, as well as legal and regulatory teams.

The following summarizes why considering an ESS in the portfolio of projects may be relevant for utility planners when planning for system upgrade projects:

- **Manage distribution investment risk:** Distribution upgrade planning is based on load forecasting, which has uncertain aspects. While a traditional wires solution is installed up-front for meeting the planning horizon needs (long term), ESS capacity can be installed incrementally as the system requires it.
- **Avoid high-upgrade costs:** Distribution upgrades compete with other projects for annual capital budgets. Deferring such projects via incremental installation of ESS capacity may reduce spending in the current year.
- **Provide additional revenue:** While ESS may replace traditional wires projects, it also has the potential to yield income from market participation.
- **Provide additional alternatives to maximize cost-effectiveness:** Allow ESS to compete against traditional system upgrade alternatives.

While these potential benefits suggest consideration of ESS projects in the planning process, limitations and drawbacks of ESS should be considered as well. This includes, but is not limited to the following:

- Lack of operational experience among utility personnel.
- Lack of support for modeling, analyzing, and operating ESS in mainstream commercial planning and operating software tools.
- Siting and permitting of large ESS systems in densely populated areas.
- Safety issues and environmental impacts of some ESS technologies that may be poorly understood by local building departments.
- Unfamiliarity with ESS systems can lead to difficulties in procurement, especially with regards to specifications and warranty terms.
- Contractual and operational mechanisms that can ensure reliable operation of ESS.
- Cost treatment of charging and discharging the energy of ESS facilities and applicability to other retail tariffs or costs.
- Lack of clarity on the revenues available to ESS through participation as a bulk market resource
- Considerations of a utility's interest and control over Federal Energy Regulatory Commission (FERC) jurisdictional bulk markets and transmission assets.

1.3.2 Reliability Improvement

This case refers to utilizing ESS to enhance and ensure the reliability of distribution system operations primarily by minimizing the impacts of outages.

1.3.2.1 Technical Challenges and Role of Energy Storage Systems

Utilities are always seeking to maintain or improve the reliability of the distribution system while minimizing utility-customer cost impacts. In general, utilities seek to achieve the following distribution reliability objectives: (1) reduce the frequency of both momentary and sustained outages, (2) reduce the duration of outages, and (3) reduce the operations and maintenance costs associated with outages and power quality management. ESSs provide opportunities to improve system reliability. Depending on the application implemented, ESS can reduce the impacts of a sustained outage or, potentially, completely avoid the outage. ESS can provide opportunities for reliability improvement in areas where traditional reliability upgrades are expensive, such as in areas with insufficient circuit-tie capabilities. These can occur in rural areas or even in urban areas with limited access by other circuits (e.g., peninsulas, steep canyons, or the edge-of-service territories).

For reliability enhancement, the priority is to utilize ESS to serve the load (mainly residential) of a selected area on a circuit during outages, as a temporary microgrid. For this purpose, ESS should be equipped with appropriate control frameworks to provide reactive power, voltage, and frequency regulation.

In a microgrid application, ESS is normally coupled with other energy sources mainly to provide energy sources to a larger customer number and classes (mainly residential and commercial). The microgrid boundaries should be bordered by reclosers or supervisory control and data acquisition (SCADA)-controlled switches to isolate the area subsequent to an islanding event and synchronize it back to the system. The microgrid energy sources are equipped with reactive power capabilities, voltage, and frequency controls. Table 1 summarizes applications related to reliability enhancement along with their economics and required ESS capacity duration.

Table 2. Summary of Outage Management Improvement Applications

OUTAGE MANAGEMENT IMPROVEM			
Application	Economics	Duration	Remark
Customer-based reliability enhancement (temporary microgrid)	May be positive for areas with no circuit-tie capabilities	Two–eight hours	Providing additional benefits if the use of ESS will not be considered during high-load periods
Microgrid application	Positive if coupled with other DG resources (e.g., photovoltaics [PV])	Two–six hours	The area under ESS coverage (microgrid boundaries) should be bordered by reclosers or SCADA switches to isolate the area

Aside from the microgrid application, ESS can be also utilized for some secondary applications such as market participation during normal operation. Even more critical, as described earlier in the distribution capacity deferral use case, the utilization of ESS for any secondary applications should be limited such that there is always enough state of charge (SOC) available in the ESS to be utilized for support during unplanned outages. This may severely limit or eliminate the opportunity for secondary applications.

For reliability enhancement, ESS would supply the loads that would go unserved during an outage in the absence of ESS. For a radial distribution feeder, this would be the loads downstream of an open switch (i.e., fuse, reclosers, etc.) that isolates the system fault from the remainder of the radial system, or a predefined islanded area or microgrid. ESS inverter sizing will be determined from the served load profile on a peak day; energy capacity will be sized under the assumption that the ESS is responsible for supplying feeder load during typical or defined outage events. As an example, Figure 2 illustrates the worst six-hour outage that can happen on a sample feeder. The peak is 5.5 megawatt (MW) at 8:00 p.m. If an outage occurs at 6:00 p.m. (first red bar in Figure 2) and continues for six hours, the ESS is required to have enough energy capacity to supply 33 megawatt-hours (MWh) [summation of red bars] of energy and an inverter size large enough to supply peak (5.5 MW).

A statistical analysis of outage frequency and duration will need to be performed to determine the appropriate sizing of the ESS in a given location and expected system coverage. When coupled with a distribution management system, the operation of an ESS could be enhanced to provide greater coverage or operate with a longer duration based on real-time system conditions rather than statistical analysis. It is not feasible for an ESS to protect against all outages, but it is practical for achieving significant improvements in the System Average Interruption Duration Index (SAIDI) and System Average Interruption Frequency Index (SAIFI) by protecting against most outages.

Figure 2. Energy Storage System Sizing for Reliability Enhancement

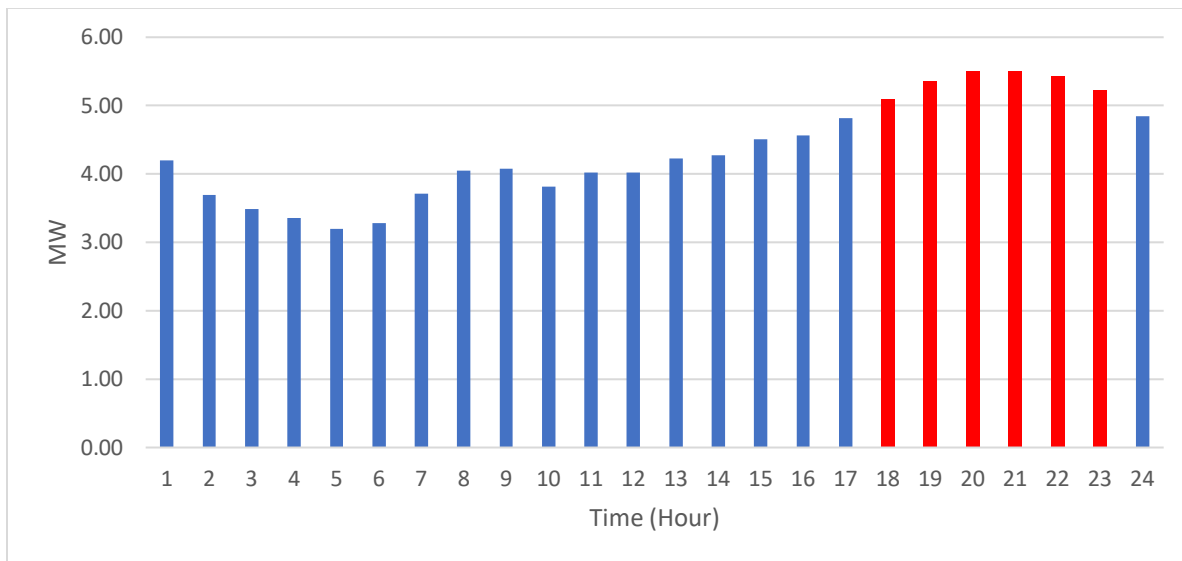

1.3.2.2 Planning Requirements

Utilities plan projects that reduce the frequency and duration of outages and reduce the operations and maintenance costs associated with outage management. Achieving these objectives has the following potential benefits:

- Higher levels of productivity and financial performance.
- Avoidance of safety problems for consumers.
- Enhanced system flexibility to meet resiliency needs and accommodate demand-side resources.
- Lower costs of electricity and more opportunities to keep rates affordable.

Due to the potential application of ESS systems to address system needs, planners should consider ESS projects in their portfolio of designed projects to improve reliability. In this context, ESS is well-suited where strict air emission regulations and/or challenges related to fuel safety may limit the use of combustion-based backup DG. Utility planners may also consider batteries for the following applications:

- **High system-enhancement costs avoidance:** Reliability enhancement competes with other projects for annual capital budgets. Deferring or avoiding such projects via ESS may provide additional budget for other projects in the queue.
- **Flexibility:** Mobile ESS applications can be used to provide a temporary or interim reliability improvement; they can then be redeployed when more traditional construction is complete.

1.3.3 Mitigation of Local Impacts of Renewable Integration

This case refers to utilizing ESS to allow high levels of renewable sources while maintaining voltage, thermal capacity, and power quality within technical standards.

1.3.3.1 Technical Challenges and the Role of Energy Storage Systems

ESS in this use case can be deployed on a distribution feeder to address photovoltaic (PV) integration challenges including overvoltage, flicker, and backfeed mitigation.

Increased penetration of renewable resources (e.g., PV) on distribution feeders can cause thermal capacity and voltage violations (steady state) beyond the accepted standards. These violations also depend on the system load as well as on the physical characteristics of the feeder.

The technical challenges can be divided into three categories: voltage magnitude, flicker, and backfeed.

Voltage Magnitude

1. Increased amounts of generation can push the voltage above the acceptable ANSI C84.1 limit.
2. The control of voltage levels can be achieved by using the ESS inverter to inject or consume volt-ampere reactive (VARs) at the circuit location whether with communications to a central control scheme or acting autonomously without communications required. The control algorithm looks at the circuit voltage and decides the VAR output. This can also be achieved by varying ESS power output; however, it may be incompatible or interfere with other applications.
3. The VAR output will impose limits on the kilowatt (kW) charge and discharge, which in turn limits the amount of capacity available for other applications. To avoid compromising an ESS's capability to perform other services, the inverter can be sized beyond the ESS power rating. The use of the inverter for reactive output is generally preferable and less costly; also, no additional ESS capability is needed. In general, to achieve the best performance and economics, the ESS should be as close to a renewable's point of injection as possible or where the circuit voltages are most affected, but this only marginally affects inverter sizing.
4. Smart inverters on PV (or other renewable) systems offer similar capabilities. Figure 3 illustrates a scenario in which the ESS inverter is used to provide VAR support to manage overvoltage and undervoltage associated with PV production.
5. In addition to controlling voltage to mitigate ANSI violations, another application would be to enable ESS/smart inverters to regulate the voltage in order to mitigate excessive tap movements in the voltage regulator and load-tap changer (LTC).

Figure 3. Energy Storage System Application for Photovoltaic Smoothing

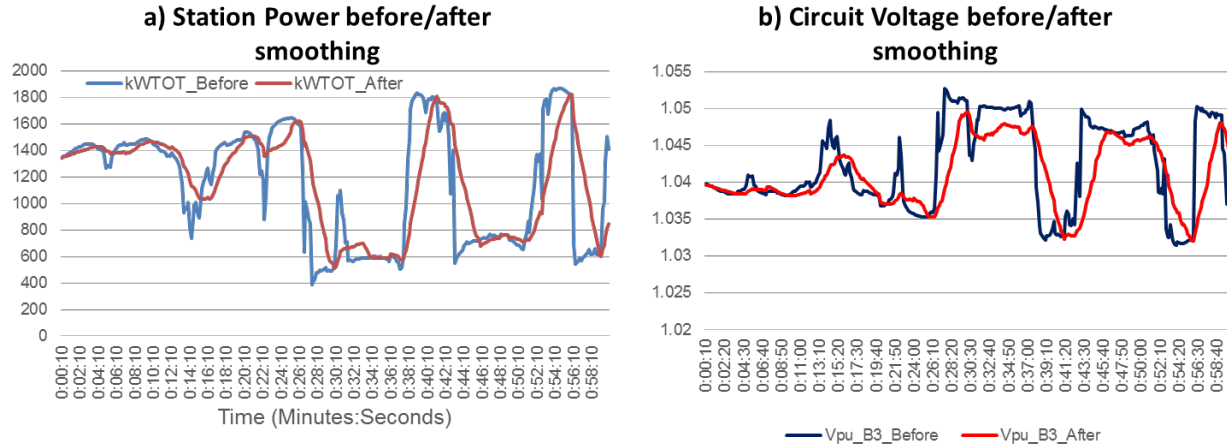

Flicker Due to Intermittency

1. Flicker is defined as a rate of change of voltage, up or down, that would cause lighting to noticeably vary. Traditionally, utilities have dealt with controlling flicker caused by load, which varies on a second-by-second basis. Introducing high levels of intermittent renewable resources contributes to the circuit load and may exacerbate the rate of change in feeder voltage or flicker. The flicker phenomenon can be controlled via rapid variation of local ESS charging/discharging to slow the rate of the combined renewable/ESS power injection and voltage change rate to within limits. For example, when PV production is dropping rapidly, the ESS discharges at a rate to temporarily mask the loss of PV generation and reduce the rate of change of voltage to within limits.
2. The ESS control can be locally autonomous and react to conditions that it can monitor locally on the feeder. The most appropriate condition for smoothing PV variability from multiple PV sources downstream of the ESS is to monitor the net MW flow on branches just downstream of the ESS. The ESS could be located at a node from which multiple branches emanate. It is also conceivable to have ESS on the secondary side of a service transformer (secondary system), where significant PV capacity is installed attempting the same application. ESS co-located with PV behind the meter is also conceivable, but this would not be the case with a utility-owned ESS.
3. The control logic attempts to control the upstream flow to maintain the change of voltage within the limits. Because the level charge/discharge and duration are limited (minutes at most) the size of the ESS can be modest, making this a cost-effective application when the alternative is reconductoring to stiffen the circuit voltage response. Static VAR compensators can provide similar benefits but are relatively expensive and are not traditional distribution voltage control solutions. Again, as solar-ESS combination systems become more and more economical, they will become a more legitimate option for managing flicker should it occur.
4. The previous Figure 3 shows less volatile station power (and circuit voltage) before and after PV smoothing achieved by proper ESS controls. For this function, the control cycle should be in 10- to 20-second intervals; otherwise, it will be too slow to be effective.

Backfeed

1. Depending on utility planning criteria of whether or not to accept reverse power flow (backfeed), ESS charging can be used to avoid backfeed at, for example, off-peak hours when solar photovoltaic (PV) production is highest (i.e., weekend afternoons on moderately hot/cool days in April/May). The algorithms for managing the ESS operation for backfeed is coordinating PV output and ESS charging/discharging to keep line flows under capacity limits.
2. Backfeed prevention would typically be compatible with optimizing wholesale energy costs or with energy arbitrage strategies. At high PV penetration in the market, prices may be low when PV production is peaking, and backfeed prevention would be compatible with optimizing wholesale energy costs. But in other situations, this may not be the case, where there could be constraints on providing ancillary services when charge/discharge capabilities are limited to prevent backfeed.
3. Backfeed can also present short-to-medium-term issues with system protection, power quality, or voltage regulation, particularly in such situations when a PV developer may want to install ESS to circumvent backfeeding and avoid paying for its mitigation (e.g., under an advanced dynamic protection scheme, where an oversized smart inverter is used to allow for dynamic voltage regulation).

Table 3 summarizes these ESS applications along with their economic benefits, the required ESS duration, and the state of commercial maturity.

Figure 4 illustrates how ESS can prevent backfeed during PV peak production in the middle of the day.

Table 3. Summary of Renewable Integration Applications

RENEWABLE INTEGRATI			
Application	Economics	Duration	Maturity
PV firming and smoothing	Can be competitive with feeder hardening	1 hour	Commercial
Volt/VAR support	Favorable under high PV penetration	minutes	Commercial
Backfeed prevention	Depends upon utility planning criteria/practice	hours	Commercial

Figure 4. Energy Storage System Application for Backfeed Prevention

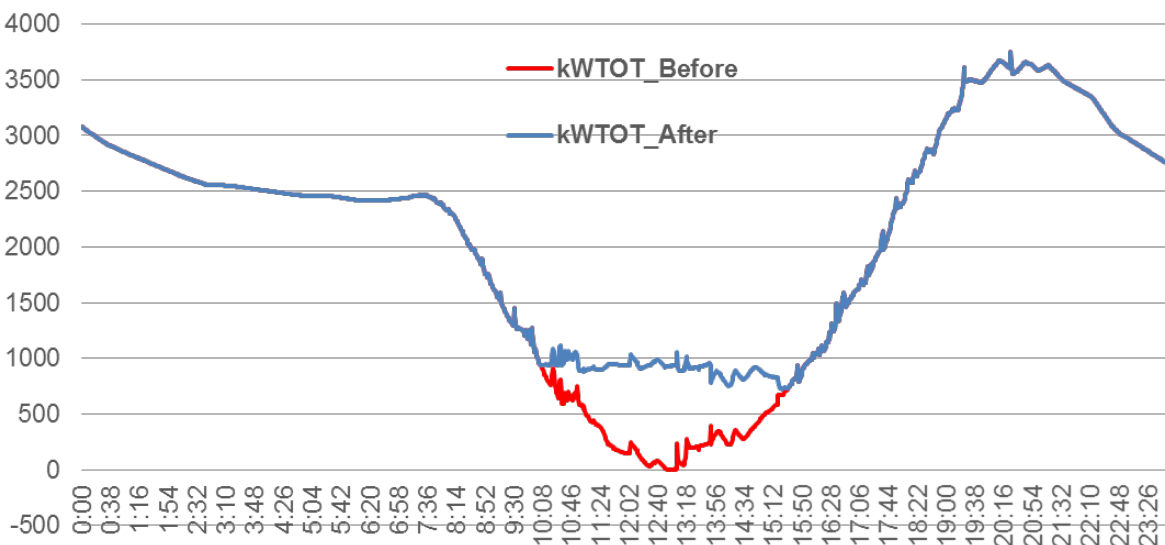

1.3.3.2 Planning Requirements

All DG interconnection requests submitted to a utility would undergo an interconnection study to examine the impact of DG on distribution feeder operations to ensure that operational limits related to power flow and power quality are maintained properly. If it turns out that some infrastructure upgrades are needed as a result of interconnecting DG, the cost is typically borne by the DG applicant. The following summarizes why ESS should be considered by utility planners while facing renewable interconnection requests:

- When identifying necessary upgrades to support renewable integration, the utility can consider ESS as an alternative to these upgrades and ESS can also offer other benefits (e.g., capacity deferral, market participation when applicable).
- There are cases when a renewables application is coupled with ESS. Therefore, the utility planner needs to understand how ESS can work in coordination with the DG to affect the interconnection. This should ultimately lead to the development of interconnection processes, standards, and/or tariffs that recognize the benefits of DG-ESS combinations, whether as a single installation or for multiple installations. Investor-owned utilities are currently piloting an “interconnection cost-sharing” method, that is designed for cases where distribution system upgrades are required to allow renewable generation integration and ESS can be considered as an alternative to wire options.

- Another scenario is when a utility has already deployed ESS for another application (e.g., peak shaving/capacity deferral) and can use the same device to mitigate adverse impacts of renewable integration into the feeder or increase the amount of DG that can be interconnected onto a feeder. Again, a utility needs to evaluate the effectiveness of that ESS device to support renewable integration.
- Individual (smaller) rooftop PV installations may not impose any issues on the feeder, in which case, “no upgrade” may be suggested by an interconnection study. However, in aggregation, these installations can create power flow violations on the feeder and, therefore, require upgrades to address a broader issue.
- Energy ESS may help increase hosting capacity by mitigating the three main technical challenges described previously: voltage magnitude, flicker, and backfeed.

1.4 Transmission System Use Cases Description

1.4.1 Mitigation of Local Impact of Renewable Integration

1.4.1.1 Technical Challenges and Role of Energy Storage System

ESS can be deployed on sub-transmission systems to overcome PV integration challenges. The purpose of this use case is to showcase the balancing relationship between ESS and PV together with the resulting system benefits. PV is an intermittent resource, and its output depends on the inverter capacity and solar irradiation on a locational basis. This inescapable characteristic results in various technical challenges, as well as possibly negative Locational Based Market Price (LBMP¹) in the wholesale market.

Currently, most sub-transmission networks are not part of NYISO’s security-constrained unit commitment (SCUC) and security-constrained dispatch (SCD). Instead, the operation of a sub-transmission system is solely the responsibility of a utility/transmission system operator (TSO) (the same goes for sub-transmission planning and improvements). For facilities that the NYISO does not secure through the security-constrained dispatch, the TSO must request a change in NYISO’s dispatch to address sub-transmission constraints (with the incremental cost borne by the requesting TSO). ESS could be used as a resource to mitigate potential sub-transmission constraints.

Steady-state challenges include line overloads and voltage violations. In particular, the hours that PV generation is high may or may not coincide with the requisite system demand to absorb such generation. In cases of high PV penetration, the excess can cause a host of thermal and voltage violations. These cases are commonly addressed with conventional network upgrades (new lines, reconductoring, etc.).

Adequately sized ESS in appropriate locations at the sub-transmission level can counteract the negative impacts of PV over injection. Specifically, ESS can absorb excess generation when loads are low and PV production is high and then discharge to support demand when load increases and generation has declined. ESS may facilitate grid interconnections by eliminating the need for expensive grid upgrades. It can also firm and shape the solar energy profile, thus improving its capacity credits and energy price as well as mitigating potential voltage deviations due to short-term solar intermittency. As a result, there is also the potential for ESS to increase hosting capacity within the sub-transmission level.

Because transmission networks are often meshed, the interdependencies of nodes suggest that there is potential for a single ESS location to alleviate overloads over several sub-transmission lines or over-voltages over more than one sub-transmission node. Note that ESS can help alleviate PV-related challenges not only by employing its charging and discharging cycles but also with reactive power injections and withdrawals through its (smart) inverter.

Figure 5 illustrates an example of using ESS to improve hosting capacity, as well as to defer transmission upgrade for a sub-transmission network. Six tapped loads are served by this networked or looped sub-transmission system with sources at each of Sub A and Sub B. Loss of Line 1 results in an overload of Line 7 or vice versa. If the overload problem is short term, siting a properly sized ESS system at any one of Subs 1 through 6 can defer the transmission upgrades to Lines 1 and 7.

Figure 5. Networked Sub-transmission System Serving Six Loads

Image depicting a networked sub transmission system.

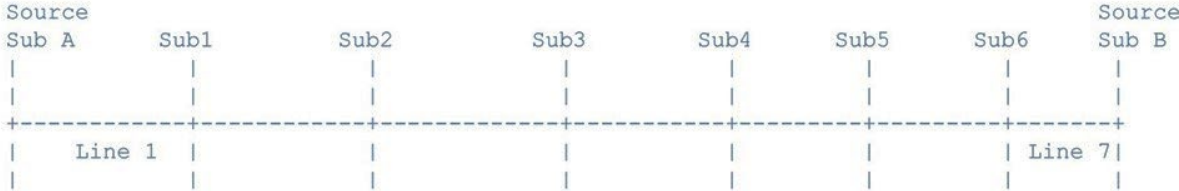

1.4.1.2 Planning Requirements

Most transmission level PV interconnections are at the sub-transmission level, meaning that renewable integration issues such as high voltage and backfeed resulting from renewable intermittency are mostly present on the sub-transmission level. Further, issues in sub-transmission may introduce secondary effects on local distribution. These issues are within the province of the utility/TSO. This use case is relevant

because state policy does not mandate that PV curtailment be part of the standard interconnection process. Further, interconnection studies are limited in their scope to a few snapshots of the system operating conditions (summer/winter peak hour, light load, high renewable generation, etc.). Daily operational issues on an hourly basis cannot be identified via an interconnection study. This highlights the benefit of the time-series analysis proposed in this research.

1.4.2 Management of Congestion

As part of this use case, the impacts of ESS devices on reducing congestion is evaluated, which may allow for more economic system operation. The use of ESS for congestion relief can be considered to enhance the capacity at the bulk transmission level to overcome emergencies that otherwise would require more expensive infrastructure investment or less efficient dispatch of generation to address congestion. For example, ESS can be set to discharge immediately after a contingency occurs which avoids running generation in case the contingency occurs and thus avoids or reduces N-1 congestion costs. In a competitive market, this alternative can be implemented by a third-party market participant but needs to respect sub-transmission level thermal and voltage constraints on the systems not secured by NYISO.

1.4.2.1 Technical Challenges and Role of Energy Storage System

N-1 conditions must be considered when clearing the wholesale market per North American Electric Reliability Corporation (NERC) reliability criteria. These additional constraints result in more expensive, out-of-merit generation dispatch or levels of generation in reserve to ensure that load is met while keeping line flows within limits under the N-1 conditions. These costs of additional reserve or generation dispatch out of merit due to N-1 contingency can be mitigated with ESS since it is capable of fast response and can immediately discharge to counterbalance the overload upon the N-1 contingency. ESS can also provide the grid operator time to re-dispatch the generation in the real-time market before the ESS is fully discharged.

The objective of this use case is to determine effective locations for and sizes of ESS, such that the ESS systems can be near instantaneously utilized, when permissible under current or future reliability criteria, to relieve congestion if the N-1 contingency indeed occurred on the transmission system. In essence, the grid operators would utilize the ESS following an N-1 contingency to allow greater pre-contingency flows (the concepts are illustrated in Figure 6). This would require, however, that the ESS be located either on unconstrained sub-transmission or on the NYISO secured system.

This use case refers to market efficiency. Congestion refers to a constrained transmission circuit that has a non-zero shadow price impacting the nodal Locational Marginal Pricing (LMP) and creating price separation between the two end nodes of the constrained transmission circuit. This market interpretation means that the line of interest is, by definition, a transmission line. However, note that ESS for this use case is still deployed within the utility territory (i.e., at the sub-transmission system). The imposed electrical distance (sub-transmission to transmission) would impact the needed ESS sizing to alleviate congestion.

There are two perspectives on using ESS for congestion relief. One is to consider the ESS as an NWA for added transmission capacity. In this case, the Regional Transmission Organization (RTO) would evaluate the ESS effectiveness in terms of market efficiency, through the reduction of LMP price separation. The ESS presumably would be a regulated asset in this case and would be treated as a transmission asset rather than a generator.

Figure 6. Demonstration of Use of Energy Storage System for N-1 Congestion Relief

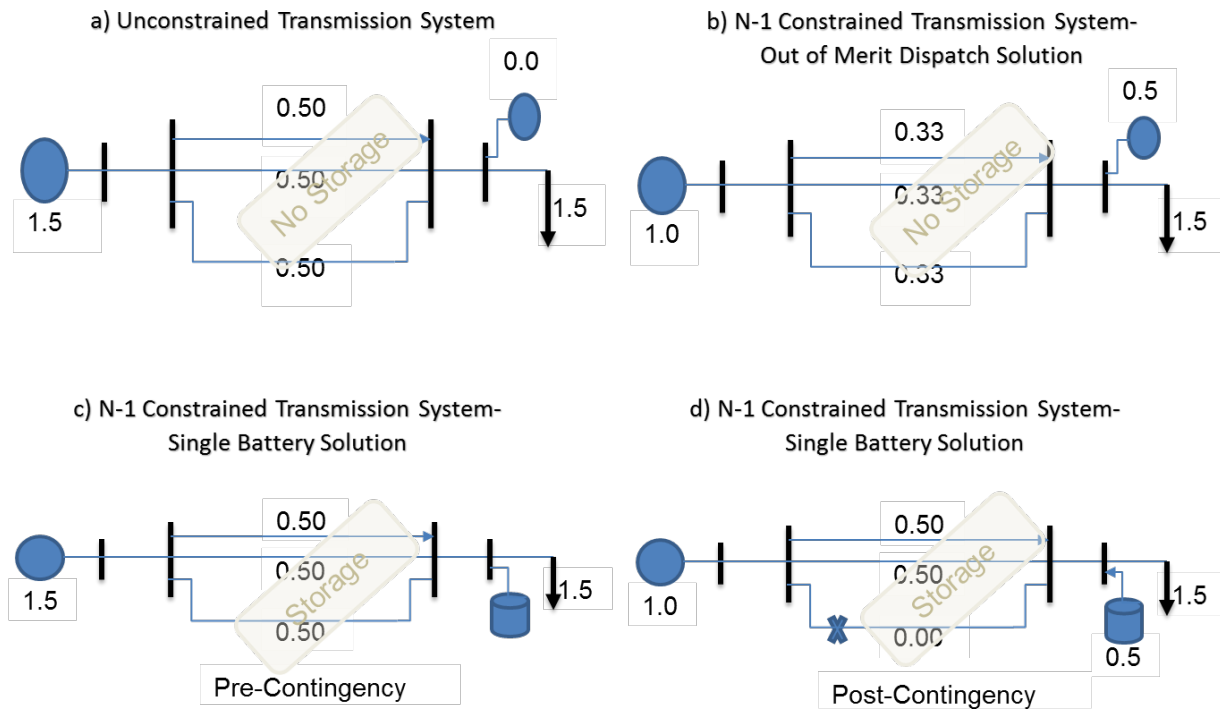

We describe an ESS valuation for the first perspective, and one that does not consider the impact of ESS on the entire market, just on the congested line in question. The broader market impact would require production cost simulations.

1.4.2.2 Planning Requirements

If the ISO considers the ESS as a dispatchable generation resource in the form of remedial action, which can be operated near instantaneously upon the occurrence of an N-1 contingency to reduce overload, the transmission asset would be more efficiently utilized by having the ESS return flows to within applicable ratings post-contingency.

The ESS solution might also be proposed as a transmission asset operated under ISO direction to relieve congestion. This business model has been proposed in several ISOs in North America. In the California ISO (CAISO), there has been one adoption of such a proposal to date. Uncertainty in rate recovery, regulatory jurisdiction, and market rules around ESS as a transmission asset can delay the adoption of this use case. An argument can also be made for this kind of resource as a regulated transmission asset.

1.4.3 Capacity Deferral

1.4.3.1 Technical Challenges and Role of Energy Storage System

Utilities regularly perform studies to find constraints and overloads that are possible within a certain planning horizon. Together with load and other forecasts, these serve as the basis for future transmission and sub-transmission expansion planning.

ESS is a new solution in this area and can work as an asset to defer the need for traditional capacity expansion, reconductoring, and new lines to satisfy NERC reliability standards. Further, ESS solutions can reduce the lumpiness of traditional expansion solutions that can result in system capabilities that exceed needs. This problem is magnified in the presence of uncertainties surrounding future load evolution and DER growth within the system. Figure 5 demonstrates a possible use case under this scenario.

1.4.3.2 Planning Requirements

Utilities regularly perform studies to identify critical future overloads. Together with load and other forecasts, these serve as the basis for future transmission expansion. The planning horizon can be categorized as the following:

- **Near-term (one to five years):** These generally identify more specific and/or “firm” projects, budgetary cost estimates, and estimated in-service dates.
- **Long-term (five to 10 years):** These identify less-specific and/or “potential” projects, planning cost estimates, and estimated in-service dates.

Utility and ISO planning goals are driven by conducting a transmission system performance assessment to maintain acceptable system performance and to demonstrate compliance with the NERC and regional planning standards (NESC®, NPCC, NYSRC,² and TSO’s local rules). As part of this process, projects are developed to reliably serve electric customers during normal and emergency operating conditions for the duration of the study horizon.

According to NYISO Open Access Transmission Tariff (OATT) section 31.2, a utility’s local transmission plans are incorporated into the NYISO regional reliability plans, which account for more constraints such as inter-regional and intra-regional limitations. NYISO evaluates the viability and sufficiency of the proposed solutions to satisfy reliability needs.

1.5 Bulk Market Participation

Bulk market participation will be considered a secondary application. All T&D applications described previously are primary applications: the ESS is sized to accommodate the primary application and any remaining capacities will then be allocated to market participation. ESS can provide a variety of energy market products (see Table 4). The market benefits are calculated considering the ESS as a price taker for all products and solving a linear optimization problem that maximizes revenues subject to ESS constraints, like remaining megawatts or megawatt-hours, etc.

This use case addresses secondary utilization of the FTM ESS for revenue generation in the wholesale market. NYISO currently allows ESS resources to participate as Energy Limited Resources (ELR) and Limited Energy ESS Resources (LESR). A brief comparison is provided in Table 4.

Table 4. Comparison of Front-of-the-Meter Market Participation

Existing ESS Resource Participation Models	ELR	LESR
Market services	Energy, capacity, regulation, operating reserves	Regulation
Description	Economically offer energy and ancillary services in day-ahead and real-time markets	Economically offer regulation in day-ahead and real-time markets
Minimum size (MW)	1	1
Aggregation	no	no
Time component	Must be able to run maximum output for 4 consecutive hours*	Cannot sustain maximum injection/withdrawal for longer than 1 hour
Payment	Capacity payment through NYISO auctions or bilateral contracts; paid energy and ancillary service clearing price	Regulation market clearing price: energy settled at hourly LBMP for net output

* Subject to changes as part of capacity market requirements re-design.

NYISO has the responsibility to oversee wholesale interconnection requests to the FERC Jurisdictional System to determine market impacts and needs and to administer the Public Policy Transmission Planning Processes, which includes cost allocation and cost recovery. It is the entity responsible for all aspects of ESS as a wholesale market participant, although this ESS may connect to a non-FERC jurisdictional system.³ This means that the following current and future use cases for ESS fall under NYISO jurisdiction:

- Capacity market participation
- Energy market (day-ahead, hour-ahead, real-time) participation
- Ancillaries participation (market-based)—reserves, regulation service
- Ancillaries participation (non-market-based)—black start, voltage support

The transmission utility’s role in all of these market-based issues is the same as with any generation resource—to support interconnection, maintain system reliability, implement just and reasonable rate cases for transmission expansion projects, and so on.

The black start ancillary service may be a bit more complex. The criteria for black start require that (1) a cranking path from the unit to the rest of the network to be restored, (2) the resource is capable of black start without transmission voltage, and (3) the resource can be connected to the transmission network without having to connect interrupted load. The transmission utility may need to be involved in the discussions as to whether an ESS resource will meet all reliability criteria and rules with existing SCADA and protection.

With respect to the voltage support ancillary service, system operators such as NYISO have respective tariffs, typically a flat fee schedule, for the ESS resource to participate. The qualification is typically addressed during the interconnection processes.

Current NYISO models do not fully capture the services that ESS can offer to the market, but with the recent FERC Order 841 compliance filing, NYISO has created several new wholesale participation models for large and aggregated ESS resources going forward.⁴

For each primary use case for energy ESS deployed at distribution and sub-transmission system levels, as discussed in section 1.3, the use of ESS to participate in the NYISO wholesale markets as a secondary application will be considered. The market products will include energy, regulation, reserves, and capacity. The idea is to maximize the utilization of an ESS resource when it is not in conflict with its primary application and to allow value streams to increase the cost-effectiveness of the ESS. As such, an ESS resource participating in wholesale markets not only has to adhere to each specific market product rule and requirement but also must maintain the operational obligations of the primary application. In addition, the ESS resource cannot introduce technical violations (thermal overload and/or voltage violations) into the distribution and/or sub-transmission system.

1.6 Energy Storage System Ownership and Operations Models

Under each transmission and distribution application, several planning requirement issues are discussed. The objective of considering different ESS ownership and operations models is to explore what business model can make the most out of a specific application. For example, in the case of ESS to support PV integration at the distribution level, one model might be ESS installed by a developer in conjunction with a solar installation. The Public Service Commission (PSC) order⁵ on the ESS goal and development policy recommends that earning mechanisms be applicable to all utilities; this would create incentives for utilities to consider new technologies such as ESS to reduce overall ratepayer cost while achieving the State's policy goals.

Therefore, the study team considers potentially different ownership and operation models:

- The utility owns and operates the ESS and rate-bases the capital cost of ESS. Any net revenues through market participation by operating the ESS facility would be returned to the customers through rate adjustments.

- A third-party developer owns the ESS and contracts with the utility for distribution services.
- Shared services can occur where either a third party or a customer deploys the ESS and the utility contracts with the ESS owner during the intervals that grid-support functions are needed. In this model, the utility operates the ESS per bilateral contracts. Payment arrangements for the service(s) provided can be arranged between the ESS owner and the utility.
- Another business model is that an ESS company installs batteries, retains ownership, and charges customers either a subscription fee or a percentage of the customer's energy savings.
- The last use case is where the ESS in combination with renewables can become part of an interconnection, possibly under an alternate tariff.

2 System Characterization

2.1 Introduction

After identifying potential use cases for ESS applications, and before any detailed analysis is performed (namely sizing and siting), electric utilities should, ideally, identify distribution circuits/feeders, sub-transmission elements, and the characteristics of each to assess the potential applications of ESS. Circuits and systems with common parameters and characteristics can be used as guidelines (criteria) to identify areas that can benefit from ESS applications. This exercise can essentially act as a screening of the system to narrow down areas that can benefit from certain applications of ESS.

Within their planning processes, electric utilities have established investment-decision processes based on corporate strategies and regulatory mandates aiming for reliable, safe power system operation to meet technical standards at a lower cost. The investment-decision process includes, among other things, screening steps to identify overloaded system elements, worst-performing circuits from a reliability perspective, areas with the potential for high PV penetration levels, and congested system elements. Those screening steps are included in the process to identify circuits and transmission system elements for ESS applications.

As discussed in the use case descriptions (sections 1.3 and 1.4), ESS application may be a comparable alternative to wire solutions in addressing the following:

- Distribution system
 - Capacity deferral
 - Reliability improvement
 - Mitigation of local impact of renewable integration
- Transmission system
 - Mitigation of local impact of renewable integration
 - Management of congestion
 - Capacity deferral

The overall ESS application process for the T&D system, comprised of five sub-processes, is represented in flowcharts in Figure 7 (for transmission) and Figure 8 (for distribution). This section describes the second sub-process (i.e., system characterization), while its application within Central Hudson Gas & Electric Corp's (CHG&E) system is presented in section 7 and section 8.

Figure 7. Overall Screening and Transmission System Evaluation Process

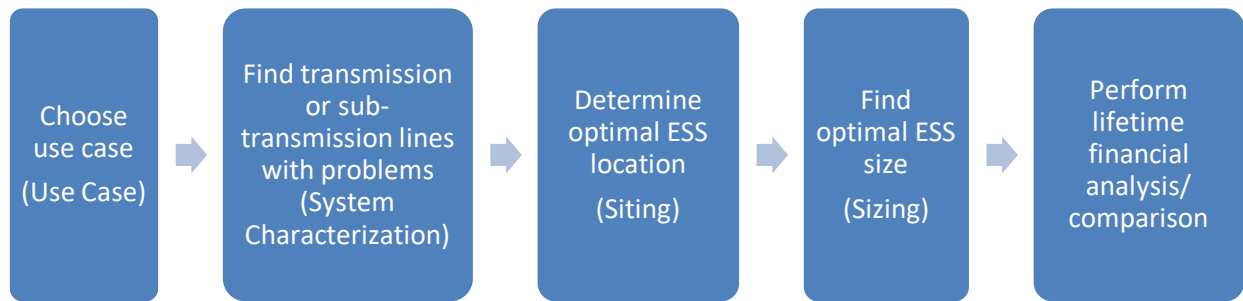
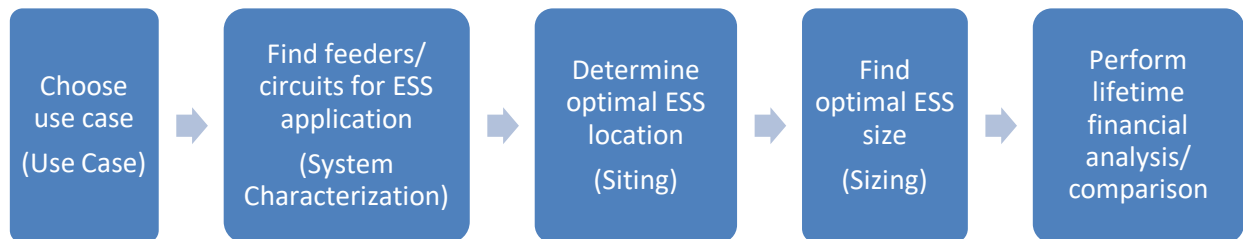

Figure 8. Overall Screening and Distribution System Evaluation Process



The feeder selection process approach discussed in this section is detailed in the following paragraphs.

2.2 Distribution System

2.2.1 Capacity Deferral

For capacity deferral, the objective is to identify and relieve overloaded or potentially overloaded distribution circuits (peak shaving). The circuit load profile (e.g., hourly resolution—8760 hr.) and the asset ratings are needed as inputs to circuit characterization. As an alternative to traditional wire-driven options, properly engineered and utilized ESS can mitigate overloads at the substation and/or on other feeder equipment.

The screening step aims to test all distribution feeders based on an overloading index (OI), also called a utilization factor (UF), which is the ratio of the forecasted peak demand load to the rated feeder capacity. IO/UF can be expressed as follows (Equation 2-1):

Equation 1. Overloading Factor or Utilization Factor

$$OI = UF = \frac{MD \text{ (MVA or Amps)}}{Capacity \text{ (MVA or Amps)}}$$

Where:

- OI = Overloading index
- UF = Utilization factor
- MD = Forecasted peak demand, expressed in MVA or amps
- Capacity = Feeder capacity expressed in MVA or amps

Forecasted peak demand is determined by applying the forecasted growth rate to the historical peak demand. The forecasts for load growth can extend to 3, 5, 10, or even more years in the future and are based on utility load forecasts (including probabilistic methods) and planning criteria. It is preferred to apply a circuit-level growth rate, which considers organic and identified spot loads.

Feeder capacity is limited by the lowest capacity of existing feeder-head equipment, including the feeder circuit breaker through the first terminal pole (transitioning from underground to overhead construction) or the first underground lateral. The lowest capacity of the feeder-head equipment may consider the capacity of the following: (1) circuit breaker, (2) reactor, (3) voltage regulator, (4) thermal capacity of ducted cable, (5) cable terminal, (6) voltage level at the distant feeder section, etc.

Under normal conditions, radial distribution feeders with OIs above 1.0 are limited in their ability to accommodate additional loads from adjacent feeders. Those feeders also prohibit the possibility of providing access to new loads; as such, the objective of any mitigation plan is to increase the available feeder capacity (i.e., total energy throughput). An OI higher than 1 is allowed under emergency conditions (i.e., N-1 outage or worse).

All feeders are grouped and ranked based on the OI tiers for a planning year. Tiers are to be defined by the electric utility and planning year based on the distribution planning criteria horizon (e.g., 3 to 5 years). Table 5 lists suggested OI tiers. Those within Tier 3 are selected for the next study stage, which is to evaluate the sizing and siting of the ESS applications.

Table 5. Capacity Deferral Tiers Definition

Overloaded Index (OI)		
OI Tiers	Lower Limit	Upper Limit
0	0%	90%
1	90%	95%
2	95%	100%
3	100%	--

An overview of the infrastructure and capacity support screening process is depicted in Figure 9. However, before performing this step, the electric utility would investigate low-cost options (e.g., switching, capacitor banks, etc.)

Figure 9. Screening Process: Infrastructure and Capacity Support

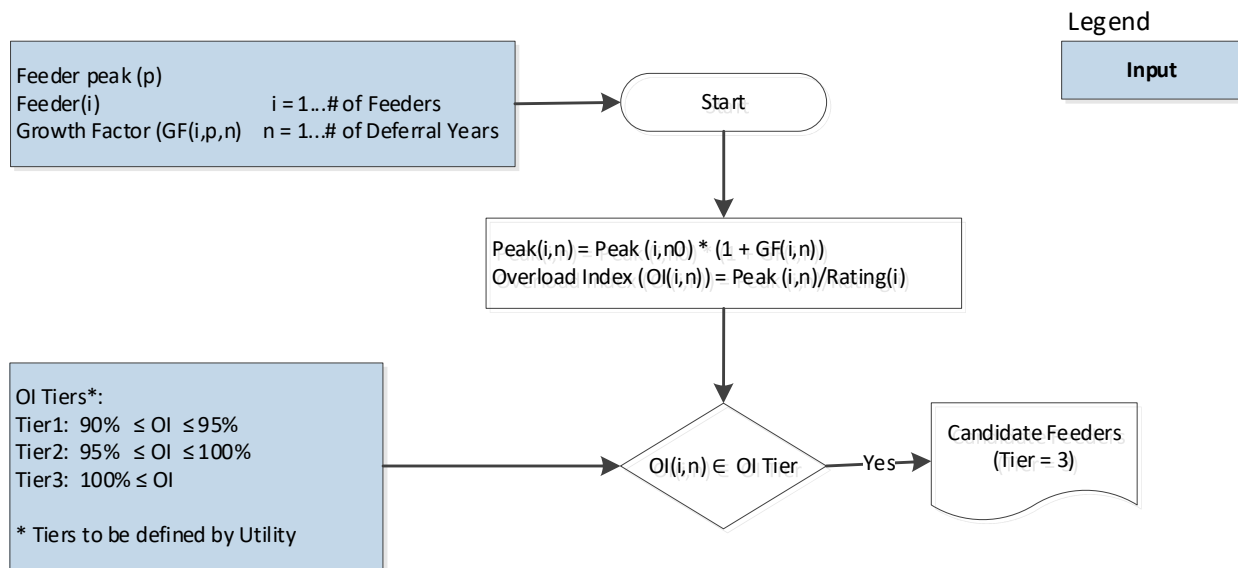

2.2.2 Reliability Improvement

This case refers to utilizing ESS to enhance distribution system reliability primarily by reducing the duration of outages, as well as customer interruption of those located outside of the impacted circuit section.

Screening for reliability improvement is a two-stage process, which starts with evaluating the reliability indices of all distribution feeders. The first stage is a numerical evaluation that ranks distribution feeders on a worst-performing basis. A more sophisticated outage management system (OMS), if available, can provide performance information at the feeder-section level to identify worst-performing feeder sections. The second stage requires a deeper outage analysis to identify outage causes and locations. The numerical analysis (first stage) is therefore complemented with a brainstorming session with field-operation groups who know the operating environment under which a circuit is operated. The two-stage screening process is depicted in Figure 10.

Figure 10. Two-Stage Screening Process: Reliability Enhancement

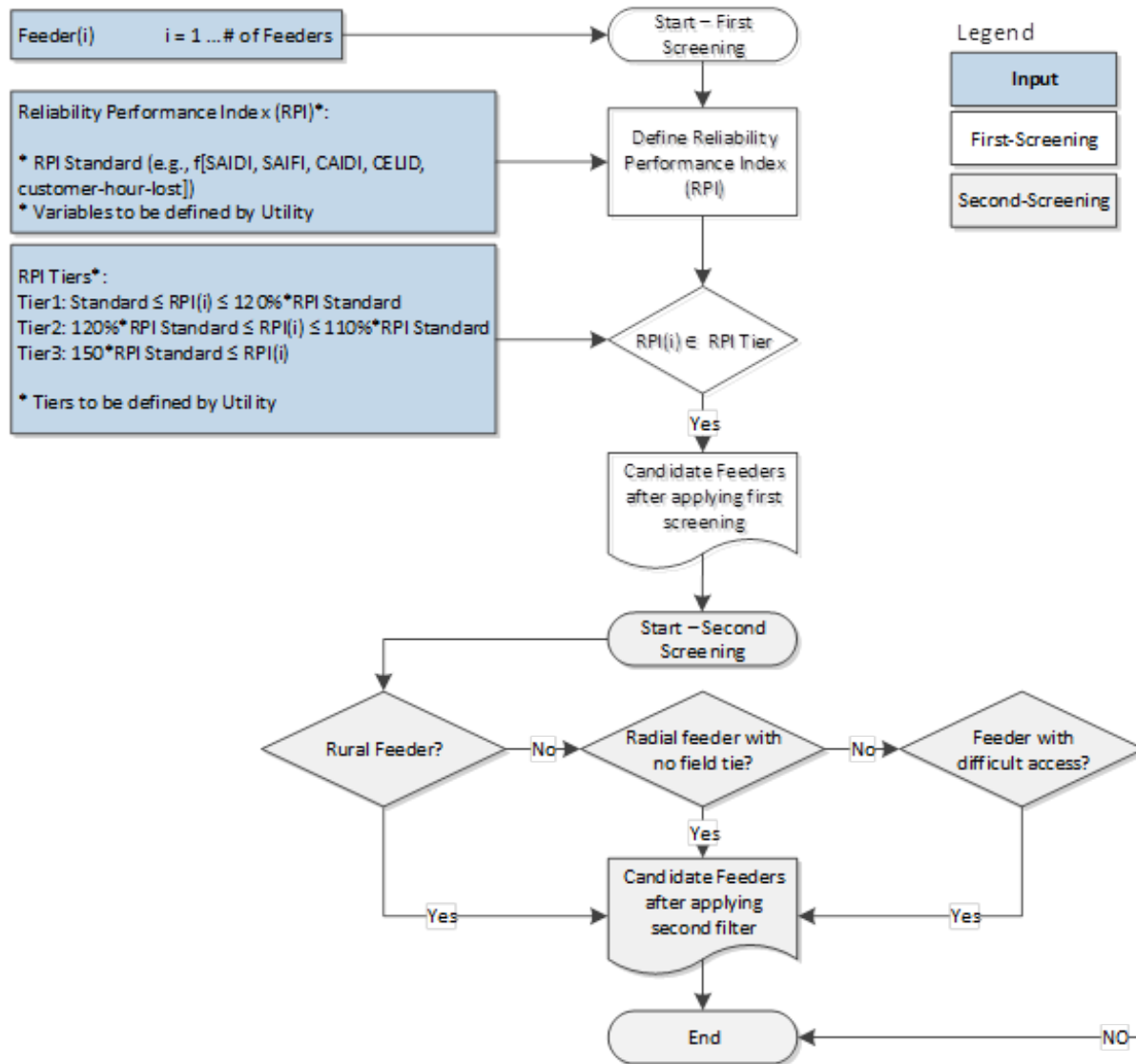

2.2.2.1 First Screening Process

The first stage of the screening process is based on a reliability performance index (RPI) calculated on a feeder-by-feeder basis to identify the worst-performing feeder from a reliability perspective. Some utilities may have a granular analysis to identify the worst-performing feeder sections instead. The RPI includes weighted (W) standard-reliability metrics. The typical metrics that might be included are as follows:

- Customer Average Interruption Duration Index (CAIDI)
- System Average Interruption Frequency Index (SAIFI)
- Customer-Hour lost (C-H) or Customer-Minute lost (C-M)
- Customer-base reliability gaps
- Customer Experiencing Multiple Interruptions (CEMI)
- Customer Experiencing Longest Interruption Duration (CELID)

Equation 2 summarizes a sample of the RPI calculation method; note that each power utility has its own methodology to determine the RPI based on its individual planning guidelines and criteria:

Equation 2. Example of Reliability Performance Index Definition

$$RPI_i = W_{SAIFI} \times \frac{SAIFI_i}{\max SAIFI_{i...I}} + W_{CAIDI} \times \frac{CAIDI_i}{\max CAIDI_{i...I}} + W_{CELID} \times \frac{CELID_i}{\max CELID_{i...I}} + W_{CM} \times \frac{CM_i}{\max CM_{i...I}} +$$

ESS can be used to mitigate outage durations but not outage occurrence. That is, ESS does not prevent damage to circuits from equipment failures, trees/wind, automobiles, etc. Currently, the only use case for ESS for reliability is to address particular customer outage durations, typically in a part of the system where islanded, undamaged circuit sections cannot be switched to adjacent feeders.

After analyzing the RPI (or weighted average of normalized parameters), feeders with high RPIs will be selected. The number of selected feeders will depend on the utility strategy and capital investment targets. Utilities might decide to identify several worst-performing feeders (e.g., 10) or a percentage of feeders from the feeder total (e.g., 1%). After the selection is made from the first-stage screening, a detailed analysis will be performed based on outage cause and feeder configuration (e.g., rural, radial feeder with no field tie, feeder with difficult access during wintertime, etc.)

2.2.2.2 Second Screening Process

The second stage of the screening process focuses on feeders with the following characteristics:

- Long, radial feeders with limited to no capacity to transfer load.
- Feeders with limited or difficult access for field crews during restoration efforts.

The second stage of the screening process requires close collaboration with those involved in reliability, field operation, and vegetation management, who—based on their field knowledge—can provide insights into identifying feeders and/or feeder-section candidates for ESS application.

Feeders experiencing multiple interruptions due to tree touches or equipment failures may not be good candidates for ESS applications. Those issues are addressed by increasing tree trimming or replacing the failed equipment based on forensic-analysis results, respectively. In addition, feeders with field ties and multiple switches on an open loop are most likely to qualify for feeder automation application (FLISR [fault location, isolation, and service restoration]) rather than ESS deployment as a way of achieving reliability improvement.

2.2.3 Renewable Integration

To assist developers and customers with siting large, centralized (>300kW) solar photovoltaic (PV) systems, New York State’s electric utilities published hosting-capacity maps.⁶ The maps provide guidance on the approximate amount of solar PV that may be accommodated on each distribution feeder without adversely impacting power quality or reliability under current configurations and without requiring infrastructure upgrades. Through the distributed generation (DG) interconnection requests process, NYS electric utilities are responsible for analyzing the impacts DG systems have on distribution feeders and feeder sections including potential high-voltage, backfeed, or intermittency issues that could be caused when interconnecting DG. One use case of ESS could be an alternative to mitigate or minimize these issues. A suitable feeder for ESS application study could be selected if the expected total DG capacity on the feeder (both interconnected and queued DG) is foreseen to be greater than its estimated hosting capacity.

For instances where utilities may not have conducted hosting capacity calculations, and the number of selected feeders is high (hundreds or thousands), statistical clustering analysis may be recommended before analyzing the application of ESS. The statistical clustering analysis selects feeders that are

representative of a feeder population and groups them into classes based upon the distribution system’s diversity. A recommended methodology is described in “A Cluster-Based Method of Building Representative Model of Distribution System” IEEE Transaction paper.⁷

2.3 Transmission System

2.3.1 Mitigation of Local Impact of Renewable Integration

The goal of system characterization in this use case is the identification of issues related to the integration of renewables. Therefore, the following steps are implemented:

1. Compile a list of renewable interconnections from the NYISO queue and Standardized Interconnection Requirements (SIR) queue. This will include capacities, points of interconnection, and expected/actual in-service dates.
2. The analysis will determine the impact of renewables on the sub-transmission system in the time domain (i.e., 8760 load profile). Thus, for each planned renewable interconnection, an hourly resolution output will be determined as follows: (a) based on PVwatts.com for solar and (b) based on National Renewable Energy Laboratory (NREL) data for wind.
3. Short-, mid-, and long-term planned transmission network or generation changes (e.g., transmission build-out, generator retirements, and additions) need to be reflected in the base case in order to successfully identify the impact of renewables.
4. N-0 and N-1 impact analyses will be performed and are detailed in the following paragraphs.

The result of the aforementioned steps is the determination of overloaded lines and voltage violations, which often appear in the vicinity of the interconnection points.

For N-0 analysis, the flow of any network line l after the injection of renewables at node n is calculated as the sum of (1) the initial flow prior to the renewable interconnection, plus (2) the power transfer distribution factor (PTDF) of the interconnection point n to the line l times the magnitude of injection (Equation 3).

Equation 3. Power Flow of Any Network Line, N-0 Analysis

$$P'_l(h) = P_l(h) + \sum_n PTDF_l^n P_n^{ren}(h)$$

Similarly, for N-1 analysis, the flow on any line in the presence of the additional renewable injections during the outage of another line is calculated as the sum of (1) the initial flow prior to the renewable interconnection plus (2) the outage transfer distribution factor (OTDF) of the interconnection point n to the line l multiplied by the magnitude of injection (Equation 4). The OTDF is the impact of a nodal injection on a line post outage.

Equation 4. Power Flow of Any Network Line, N-1 Analysis

$$P_l''(h) = P_l(h) + \sum_n OTDF_l^n P_n^{ren}(h)$$

Branch loadings can be estimated for typical peak summer, winter, and shoulder (spring/fall) light-load conditions based on Equation 3 and Equation 4. If a dispatch model is available, it is recommended to compute 8760-hr estimates to identify the maximum loading across all hours (or load conditions) of both the N-0 post-renewable flow \bar{P}_l' as well as the N-1 post-renewable flow \bar{P}_l'' (Equation 5 and Equation 6):

Equation 5. Branch Loading of Load Profile, Post Renewable, N-0 Analysis

$$\bar{P}_l' = \max_h P_l'(h)$$

Equation 6. Branch Loading if Load Profile, Post Renewable, N-1 Analysis

$$\bar{P}_l'' = \max_h P_l''(h)$$

These results will be compared to the lines' reasonable ratings to determine whether an overload exists.

2.3.2 Management of Congestion

As part of this use case, the impacts of energy ESS devices on reducing congestion are evaluated to allow for improved asset utilization. More specifically, the use of ESS for congestion relief can be considered to improve economic operation of the transmission system in order to avoid requiring more expensive infrastructure investment or less efficient generation dispatch. For example, ESS

can be used as a non-wires alternative (NWA) to peaking generators for an N-1 situation where this resource can be discharged, either pre- or post-contingency, to relieve the overload or congestion. In a competitive market, this alternative can be implemented by the utilities through ESS that is directly owned, contracted from a third party, or operated by a third party under other arrangements.

Using a market approach, congestion is characterized as nodal price separation. Therefore, system characterization for this use case refers to narrowing down the high-voltage portion of the transmission network to lines that are binding and whose shadow price is non-zero. The LBMPs at the sending and receiving ends of such lines will differ. The following are the methodology steps outlined in greater detail:

1. Determine the most-possible future scenario (or scenarios). Assumptions that can differentiate future system states are mostly pertinent to generator additions and retirements, fuel prices, transmission work, and state policies (e.g., limitations on types of fuels used, emission allowance prices, and amount limitations, etc.).
2. Perform market analysis for each plausible scenario. Output results will include nodal clearing prices, congestion components, and binding/congested lines.
3. Relate the hours of high-congestion components of the LBMPs to the binding lines responsible. These lines, together with high-contribution loads identified by nodal PTDFs are the result and the focus of system characterization in the congestion use case.
4. In the absence of such congested lines in the territory of interest, apply either or both alternate approaches as described:
 - Add more severe contingencies within or near the area of focus. Most commonly these include the loss of a baseload generator or the concurrent outage of high-voltage transmission lines.
 - Look at congested lines outside, but still close to, the area of interest.

This time series analysis approach equates to an 8760 analysis since constraint impacts during all hours of the year have been considered in NYISO's Congestion Assessment and Resource Integration Studies (CARIS).

2.3.3 Capacity Deferral at Sub-transmission System

For this use case, transmission network screening can be thought of as a natural result of the utility's list of planned projects to enhance transmission reliability. In other words, a planned reconductoring of a transmission line signifies that this transmission line should be part of the screened system.

3 Siting and Sizing

3.1 Introduction

A single methodology for optimal ESS siting and sizing is applicable for all sub-transmission use cases. For distribution feeders, a single ESS location is assumed, and then a use-case specific methodology to size the ESS (power and energy sizes alike) is addressed in the following section.

3.2 Distribution System Applications

3.2.1 Peak Shaving

To deal with feeder overloading conditions or to increase feeder capacity, distribution planning engineers explore the following typical wire options:

- Transfer load to an adjacent unloaded feeder via existing laterals and field ties or with a new lateral.
- Reconductor the overloaded cable or conductor, which typically is at feeder egress from the substation.
- Implement a new feeder position and new mainline (underground and/or overhead).
- Substation capacity enhancement (new transformer) or new substation.

The objective of those options is to relieve the overloading stress of the feeder section during peak demand conditions. Figure 11 shows a representation of an overloading condition.

Figure 11. Energy Storage System Located Where Overloaded Section Ends (Downstream of SUB)

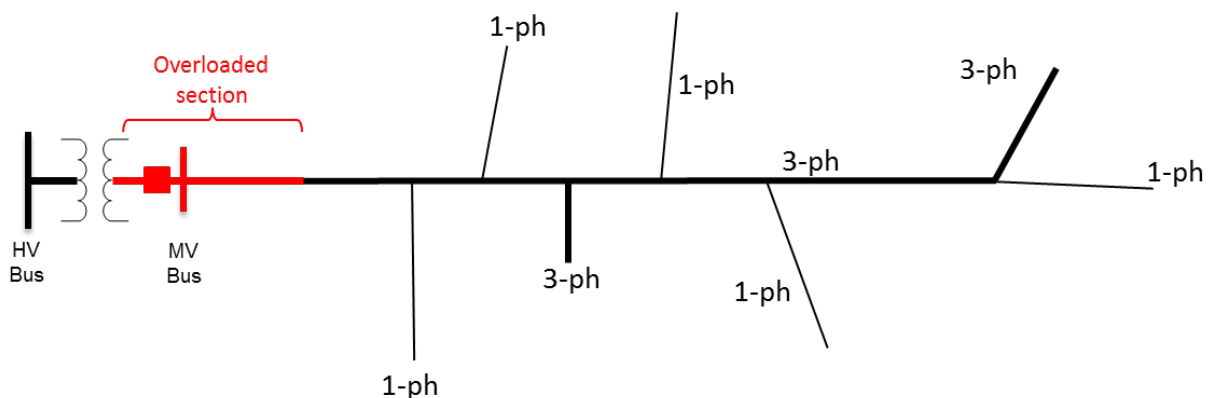

ESS is an alternative to relieve overloading feeder conditions by deferring wired options capacity upgrades. The following options of ESS application can be considered:

Option 1: Installing an ESS directly downstream of the overloaded feeder section as depicted in Figure 12.

Figure 12. Energy Storage System Located Just Downstream of the Overloaded Section

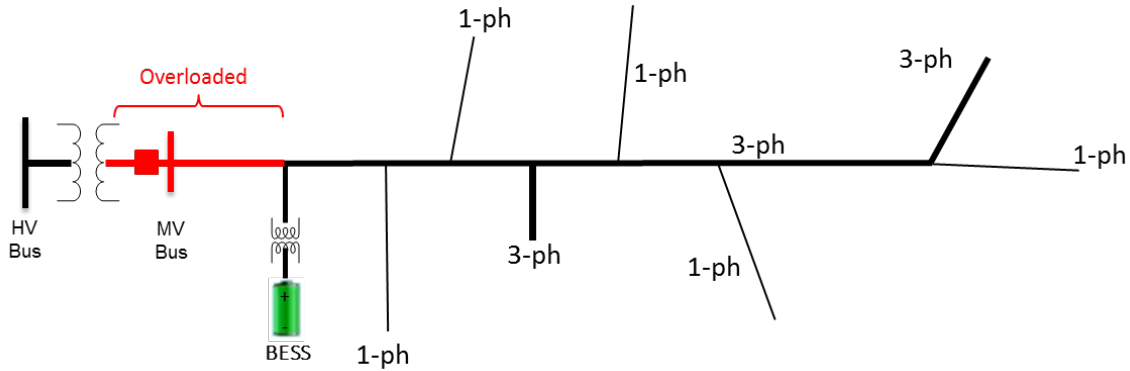

Option 2: Locate an ESS close to the heavily loaded feeder section or feeder branch. Figure 13 represents the ESS location assuming the three-phase branch is heavily loaded.

Figure 13. Energy Storage System Located Close to the Heavily Loaded Feeder Section/Branch

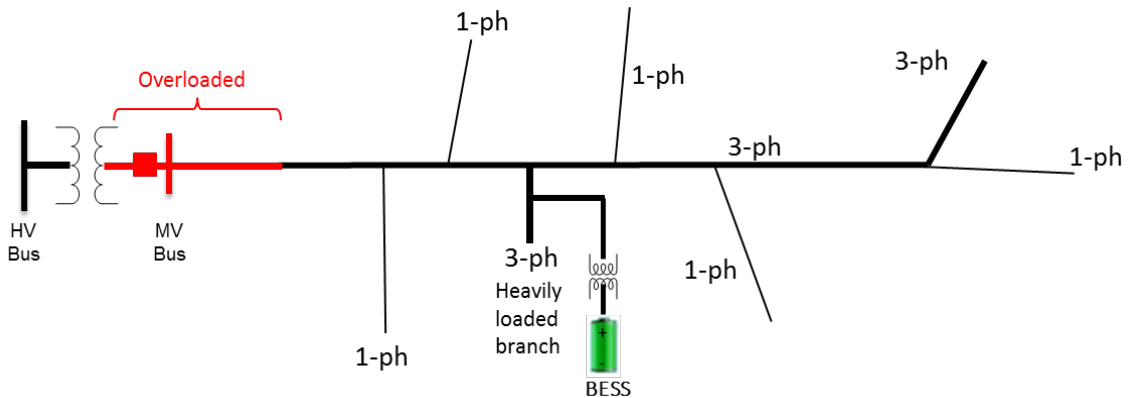

The ESS is assumed to be sited at a single location, either option 1 or 2 as described in Figures 11 and 12.

The single ESS device will feed the load that exceeds the feeder nominal capacity. As a result, the inverter (power) requirement will equal the maximum excess of the projected system load over the feeder capacity, adjusted for ESS efficiency loss. In other words, the power requirement will equal the difference of the projected demand peak to the feeder rating times 1.08 to account for 8% typical ESS charging/discharging efficiency loss. A factor of 1.025 should also be considered to adjust for feeder power losses if ESS is not directly downstream of the overload. The energy capacity of the ESS will be the sum of the excess of the projected system load above the feeder rating, adjusted by 1.05 for ESS efficiency and by 1.025 for line losses.

An ESS's smart inverter (ESS–MW) size is given Equation 7.

Equation 7. Energy Storage System Megawatt Capacity Sizing

$$ESS - MW = (MD - FC) * 1.08 * 1.025$$

Where:

- ESS – MW = ESS capacity (inverter capacity) expressed in MW
- MD = Feeder maximum demand expressed in MW
- FC = Feeder nominal capacity expressed in MW
- 1.08 = ESS system charging/discharging efficiency capacity loss factor
- 1.025 = Feeder line losses factor (should be adjusted as needed by utility)

ESS energy capacity is calculated from the maximum MWh consumed above the feeder capacity and represented by Equation 8.

Equation 8. Energy Storage System Megawatt-Hour Capacity Sizing

$$ESS - MWh = (EMDD - EBFC) * 1.08 * 1.025$$

Where:

- ESS – MWh = ESS energy capacity, expressed in MWh
- EMDD = Energy during maximum demand, expressed in MWh
- EBFC = Energy below feeder capacity, expressed in MWh
- 1.08 = ESS system charging/discharging efficiency capacity loss factor
- 1.025 = Feeder line losses factor (should be adjusted as needed by utility)

Figure 14 presents a graphical representation of the ESS capacity MW and MWh calculation described in Equation 7 and Equation 8.

Figure 14. Energy Storage System Capacity Estimation (Megawatt and Megawatt-Hour)—Graphical Process

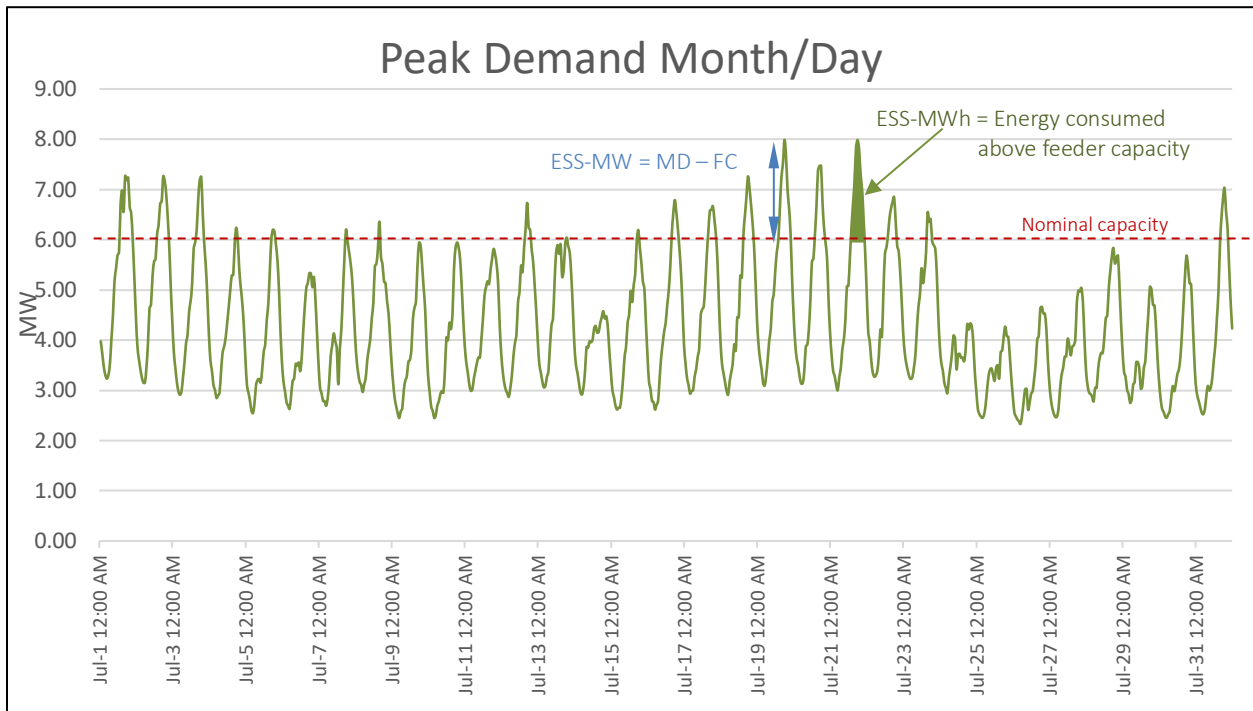

3.2.2 Reliability Improvement

To deal with feeder reliability, particularly those feeders with one of the following characteristics:

- Located at the end of the radial transmission line.
- A rural feeder with limited or no existing field ties.
- A feeder tied to another with limited capacity to transfer load during a power outage.
- Feeder sections with difficult site access during a power outage.

Utility engineers evaluate, among other possibilities, the following reliability enhancement options:

- Build a transmission line to enhance rural sub's (thus rural feeder's) reliability.
- Build an extensive distribution line to allow for the backing up of impacted areas.
- Line relocation.
- Line extension to create a field tie.
- Reconductoring main lines or ties to improve load transfer capability.
- Integrate a backup generator to feeder section downstream of impacted feeder section, typically rural feeders.

The objective of the options is to reduce the number of customer interruptions during an outage, particularly those located downstream of a line section experiencing multiple power outages. The following diagrams show some system scenarios where ESS could be evaluated as an alternative solution:

- Scenario 1. Line section experiencing multiple interruptions at the middle of the feeder (Figure 15).
- Scenario 2. Line Section experiencing multiple power outages at the Feeder Head (Figure 16).
- Scenario 3. Sub-transmission radial line experiencing multiple power Outages (Figure 17).

Figure 15. Line Section Experiencing Multiple Power Outages at the Middle of the Feeder

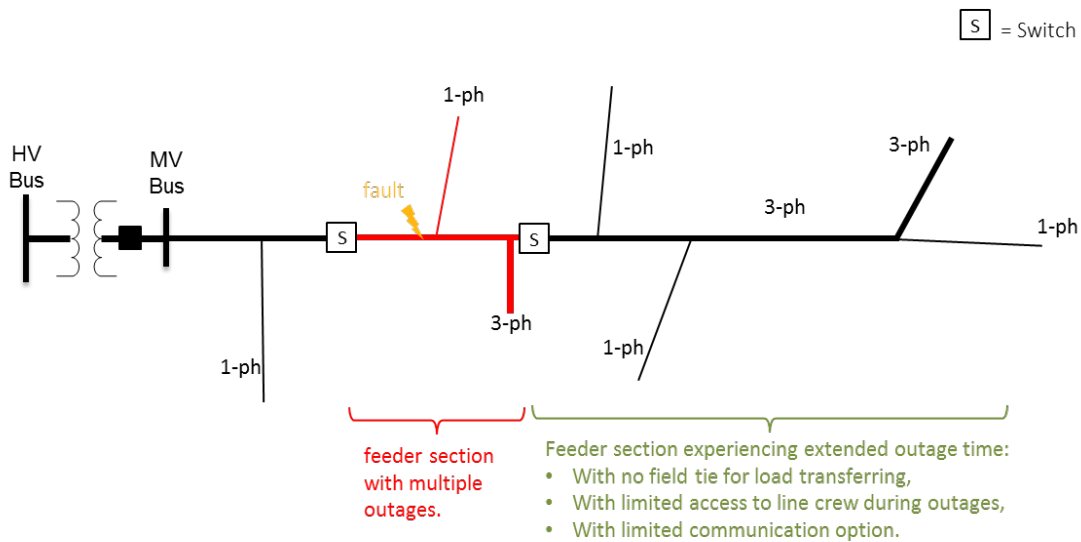

Figure 16. Line Section Experiencing Multiple Power Outages at the Feeder Head Section

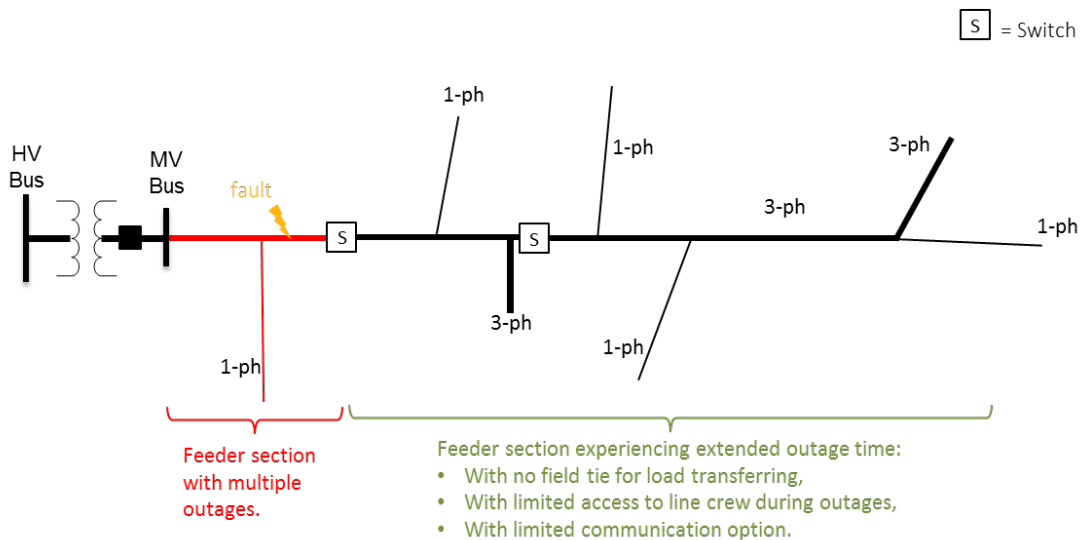
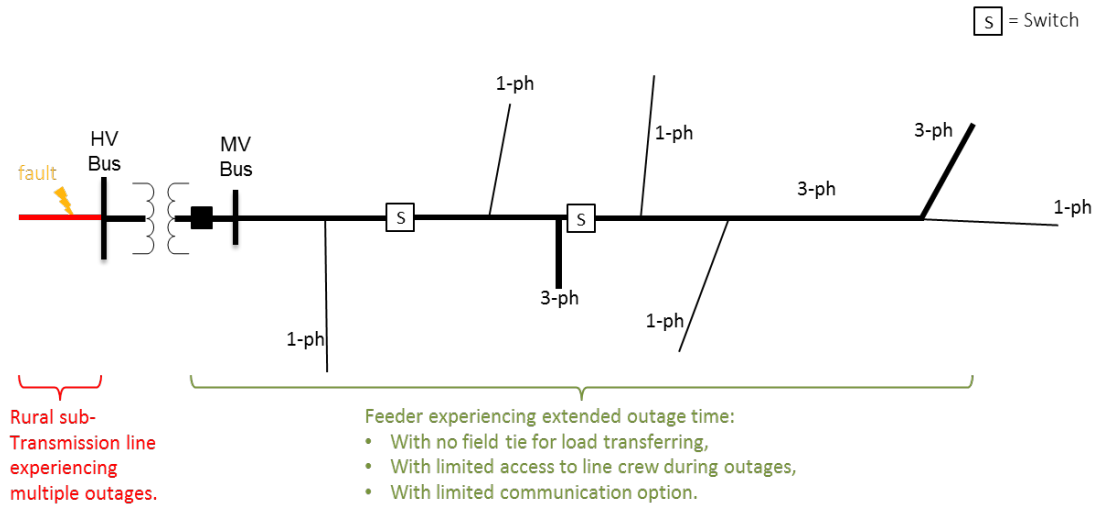
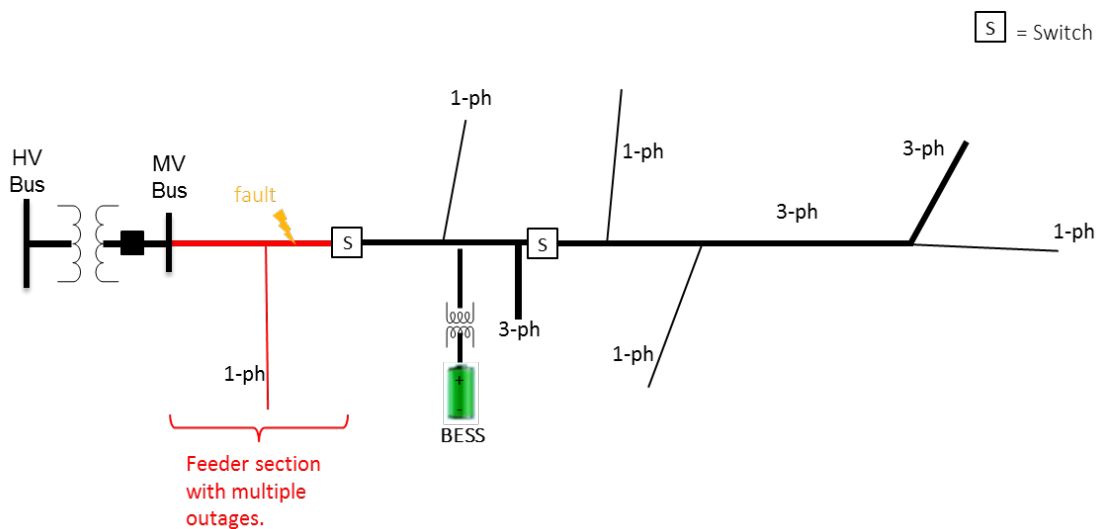

Figure 17. Sub-transmission Radial Line Section Experiencing Multiple Power Outages



For any of the three scenarios, an ESS can be located downstream of the line section experiencing multiple interruptions. A control system capable of isolating the non-impacted section is required to ensure the ESS operates properly, feeding the section for as long as the impacted line section is being repaired (e.g., four hours). Figure 18 depicts an ESS located downstream of the line section impacted by multiple outages.

Figure 18. Energy Storage System Located at the Targeted Feeder Section



The ESS inverter size will be determined from the load profile on the feeder peak-demand day. The ESS power size is determined by the maximum demand load of the non-impacted line section multiplied by 1.025 (to adjust for power losses, used only if ESS is not directly downstream) and then multiplied by 1.05 (to adjust for ESS efficiency loss).

The ESS energy capacity will be sized under the assumption that the ESS is responsible for supplying the non-impacted line section load during outage events (e.g., four or six hours). As an example, Figure 19 illustrates the worst-case, six-hour outage that can occur on a sample feeder section. The peak is 5.5 MW at 8:00 p.m. If an outage occurs at 6:00 p.m. (first red bar in Figure 19) and continues for six hours, the ESS is required to have energy capacity enough to supply 33 MWh (summation of red bars) of energy and an inverter size large enough to supply the feeder section peak (5.5 MW).

Figure 19. Energy Storage System Sizing (Red Bars) for Reliability Enhancement

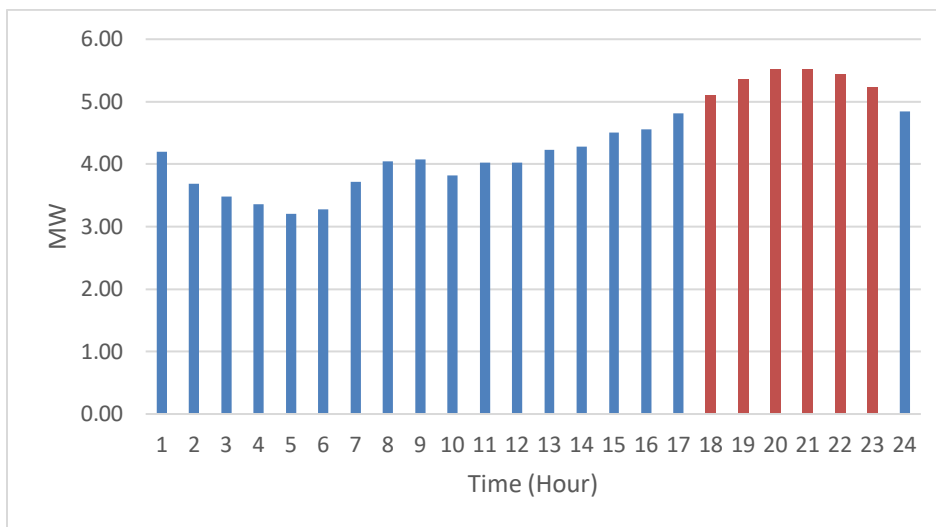

3.2.3 Mitigation of Local Impacts of Renewable Integration

For the ESS siting analysis of the screened feeders, PV is assumed to be located at the distribution bus with the lowest stiffness factor (SF). ESS will be co-located with the PV. Then, ESS sizing will be the result of a power flow analysis post-PV integration. The power flow will be solved for the hour of maximum difference between load and PV output, where the worst voltage issues are expected to occur. The voltage magnitudes, resulting from the power flow, will reveal the distribution buses where voltage exceeds ANSI voltage magnitude limits (typically 1.05 per unit).

Figure 20. Energy Storage System Sizing for Renewable Integration

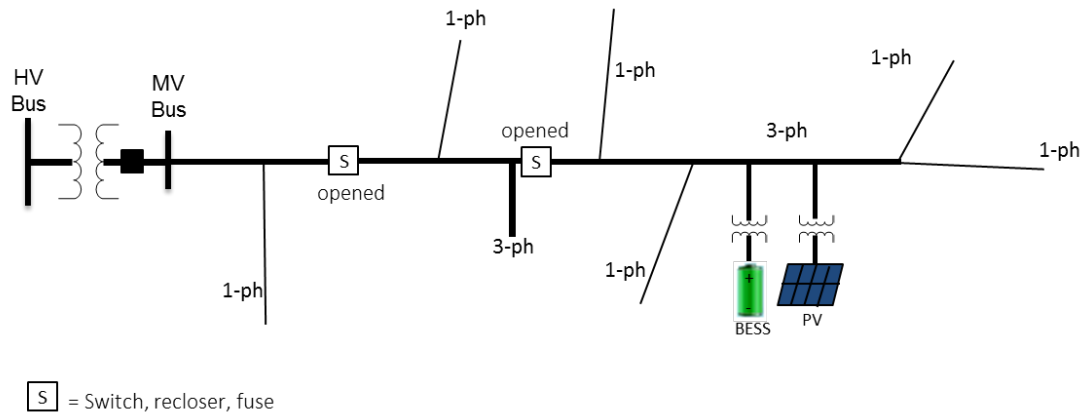

3.3 Transmission and Sub-transmission System Applications

The ESS siting and sizing methodologies described here are applicable to the use cases analyzed in previous sections of this report:

1. Mitigation of local impacts of renewables
2. Management of congestion
3. Capacity deferral

As shown in section 2.3, the system characterization/screening process identifies the overloaded lines. Optimal sites for ESS are defined as the network buses that would, in a post-contingency setting, have the highest impact on relieving these overloaded lines. To this end, each network bus n is assigned a siting index σ_n that showcases the impact on the screened elements of each use case and that is calculated based on the PTDFs and line outage distribution factor LODFs. Appropriate weighting based on (1) line capacity-constraint shadow prices, (2) line overload percentages, (3) rating, or (4) a multitude of other options may also be used to prioritize the relief of certain overloaded elements. An optional first step includes weeding out buses with PTDFs under a certain threshold (i.e., with very low impact on the overloaded elements).

If the siting index σ_n is positive, then node n is a beneficial location for ESS charging; whereas, if the siting index σ_n is negative, then node n is a beneficial location for ESS discharging. These methodologies work for single-line contingencies and can straightforwardly be expanded to work for multiple-line contingencies.

The top sites identified are then used for the sizing analysis. Assuming the potential for ESS located in any of the top optimal sites, the optimal ESS size is identified as the solution to a linear, constrained optimization problem that aims to find the least-cost ESS solution to relieve the overloads on all monitored lines. The constraints are the system power balance equation (ESS output will be offset by the slack bus) and the flow on all monitored lines after the dispatch of ESS being lower than their respective thermal ratings. Additional constraints on the maximum and minimum ESS size at each location may be added (e.g., based on constraints similar to hosting-capacity studies). The objective function is the minimization of ESS costs. The constraints and the objective function may be edited to accommodate the possibility for hybrid solutions that provide cost-effective partial congestion relief.

4 Stacked Applications Methodology

Revenue stacking aims to maximize utilization of the ESS throughout the year by providing secondary services when the ESS is unused/partially used for its primary application. Since wholesale market service provision by ESS is currently the most commercialized set of applications (due to FERC order 755), this work examines market participation as the secondary revenue stream in addition to the primary application (i.e., each of the aforementioned use cases).⁸ Just as a generator can provide real power or reserve power to the grid, so can an ESS. It can guarantee to deliver energy during a specified time, and thus, provides the ancillary service of reserve power. Batteries are also excellent at regulating power on the power grid, following load closely and matching with appropriate supply. Time-shifting and balancing arbitrage at the utility level are also applications open for ESS, selling energy when it is expensive and in high demand and charging up when energy is cheap and easy to produce from other sources. Table 6 shows a summary of ESS stacking value application.

Table 6. Market Products that Energy Storage System Can Provide

Application	Maturity	Economics	Duration	Power (MW)
Ancillaries provision—regulation	Mature as a stand-alone app	Marginal to positive	15 minutes to two hours	1–30 MW
Ancillaries provision—reserves and capacity markets	Conceptually simple and common in the ISO markets	Similar to regulation	Two hours (but less if allowed in conjunction with quick-start units)	10s to 100s of MW
Time shifting	Piloted	Marginal	Two to six hours	10s MW
Balancing arbitrage	Conceptual	Marginal to positive	< One hour	> 1 MW

Currently, the most feasible secondary applications are regulation and arbitrage. Market participation is optimized through a linear problem resulting in the optimal mix of the utilization of the (remainder of the) ESS in the energy and regulation markets. The market participation optimization model:

- Includes constraints reflecting the ESS power rating, energy rating/duration, and minimum and maximum state of charge (SOC). The market optimization will only see the remainder of ESS power after the primary application (i.e., each use case) as available, which will be equally or more restrictive than the constraint on the inverter capacity of the ESS.
- Utilizes energy and regulation historical price market data.
- Considers efficiency losses and operational costs of ESS.
- Includes provision for overloads due to ESS charging based on hourly load levels (e.g., if a load is higher than a threshold, ESS is restricted from charging).

A shortlist of the parameters to be defined to calculate market revenues, along with suggested values, is presented in Table 7.

Table 7. Energy Storage System Parameters Needed for Market Participation Revenue Calculation and Suggested Values

ESS Parameters	Suggested Value
Round-trip efficiency	90%
SOC target (start and end of day)	100%
SOC lower limit	5%
SOC upper limit	100%
Variable operation and maintenance cost	\$0.01/kWh

The objective function maximizes the earnings of the ESS through arbitrage and regulation in the wholesale energy and operating reserves and regulation service markets. Some sample results are shown in the next sections to demonstrate how battery’s market participation is modeled as a stacked application on top of primary distribution applications, capacity deferral, and reliability. The same models can be used to model ESS market participation stacked on top of transmission applications.

4.1 T&D Capacity Deferral and Market Participation

ESS deployed for capacity deferral (e.g., thermal overload relief) is typically needed to relieve thermal and/or voltage violations in limited hours of the year, the battery can participate in wholesale markets in the periods that its distribution grid service is not required. Two operation strategies are considered, as follows:

- Capacity deferral (CD) only with no additional market participation. In this case, there are some inherent energy savings that can be captured from ESS peak shaving during the periods in which the circuit is operating above its design rating.
- Capacity Deferral and Arbitrage (CDA): Participation only in day-ahead wholesale energy market. In this scenario, price arbitrage is the single driver of market revenues.
- Capacity Deferral, Arbitrage, and Ancillary Service Market (CDAAM): Participation in both day-ahead wholesale energy and ancillary (regulation) markets. In this scenario, price arbitrage and regulation payments are the drivers of market revenues.

Figure 21 illustrates an example in which ESS primary application is for peak shaving and capacity deferral. The hourly dispatch of ESS on a peak day is shown. The ESS discharges during peak hours for thermal overload relief. It participates in day-ahead energy market in non-congested hours and its

dispatch is optimized against the day-ahead LMPs resulting in charging in less expensive hours and discharging in more expensive hours. The hourly state of charge consistent with hourly charge/discharge is also shown.

Figure 21. Day-Ahead Energy Market Participation

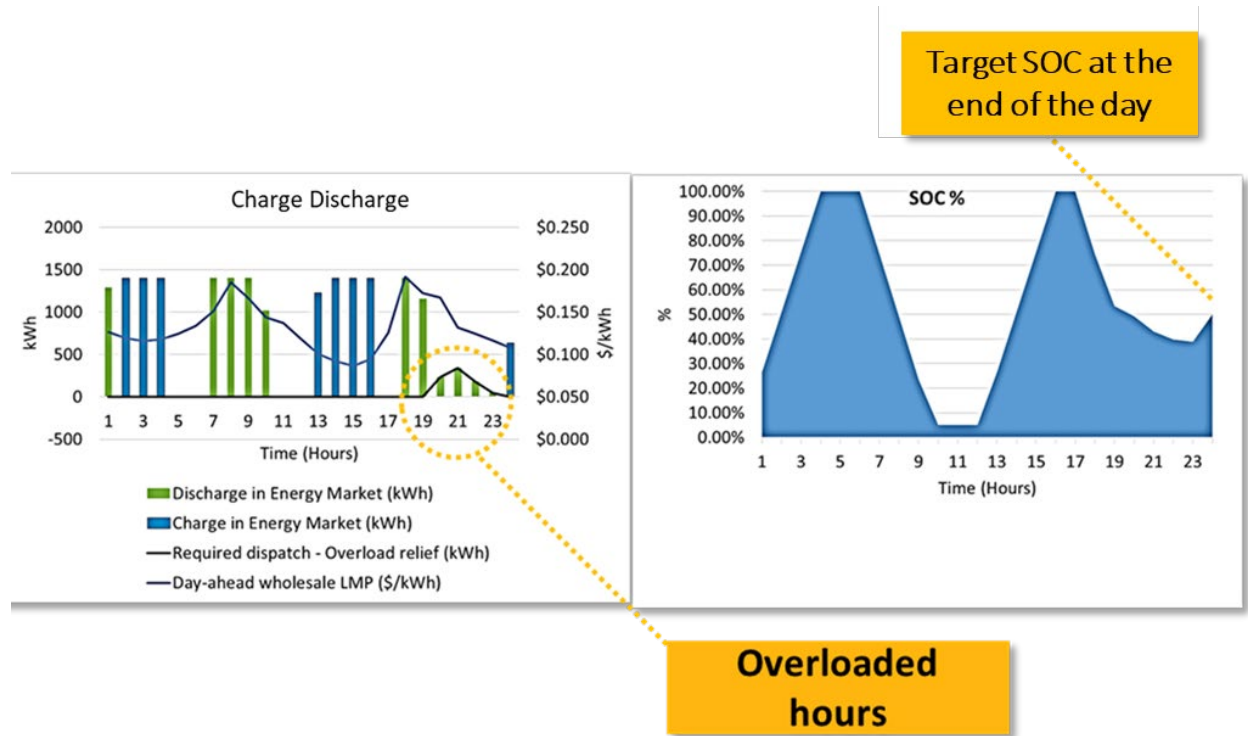

4.2 T&D Reliability and Market Participation

Another example is shown in Figure 22 where ESS is deployed to support local reliability on a distribution feeder. ESS market participation, in this case, is more limited than the capacity deferral for thermal overload because outage can happen at any time, and therefore, the battery must have enough energy stored to be able to supply impacted load for a certain duration. In the example displayed, the energy market opportunity is limited and the battery maximizes its benefit via participating in the regulation market.

Figure 22. Reliability and Market Participation

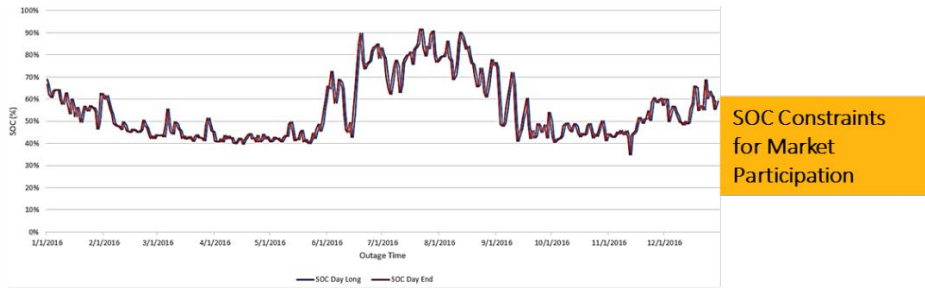

Stacked Application: Market participation without compromising reliability:

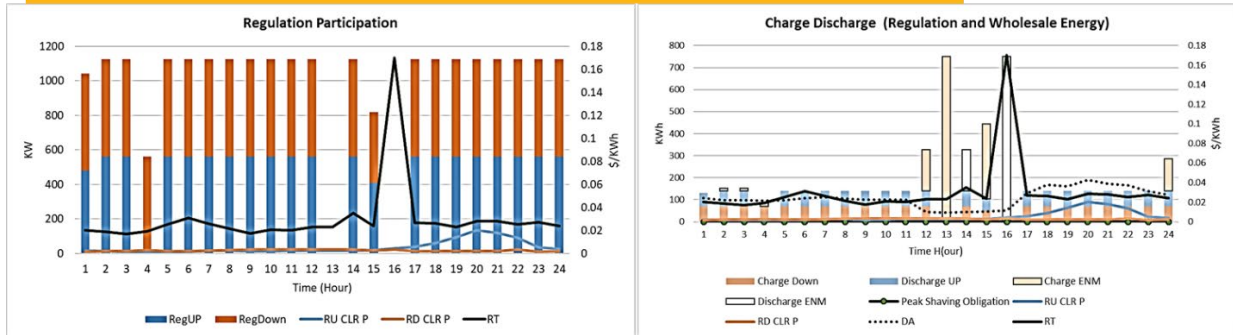

5 Benefit-Cost Analysis Methodology

An approach to express whether a project makes financial sense (e.g., ESS application) is to compare the project benefits to the associated costs by calculating the benefits to cost (B/C) ratio. Further, one should compare the benefits to the costs of the non-ESS mitigation solutions to ultimately establish whether ESS is competitive. The benefit-cost analysis (BCA) is accomplished by the following steps:

4. Identification of ESS sizing required to address issues of each use case.
5. Determination of the cost of the ESS (implementation, operation and maintenance, etc.).
6. Determination of the benefits of ESS through stacked applications.
7. Determination of the cost of the non-ESS mitigation solution(s) for each use case.
8. Calculation of Net Present Value (NPV) of the benefits and costs.

The first step in the BCA process, sizing the ESS, has been described in detail previously in section 3. The cost of an ESS device is a function of the chosen ESS's power and energy sizes. The market participation process, described in section 4 (Stacked Applications Methodology), will determine the most beneficial market products that the ESS can provide and reveal the full value the ESS can yield through these secondary applications. The financial analysis should consider capital costs including the following:

- Estimated procurement, installation, and applied overheads
- Operational costs, including the cost of:
 - Energy losses in the charge-discharge cycle
 - Maintenance
 - Depreciation
 - Property taxes
- Benefits, including:
 - Return on capital
 - Estimated market benefits

The calculated B/C ratio can be compared with the B/C ratio of a traditional wires alternative, so that an incremental benefit-cost ratio can be calculated.

The horizon over which NPV is calculated is an important factor, particularly in relation to an ESS's lifetime. For example, for an assumed 20-year NPV, a 10-year ESS would need to be replaced and disposed of, which would impact installation and disposal costs.

Multiple sensitivities should be performed to clarify the upsides and downsides of the ESS proposition. In particular, the greatest allowances should be made for the volatility of market prices, which can impact the ESS revenues.

For reliability use cases (e.g., outage management in the distribution networks, reliability related to sub-transmission, etc.), a more useful cost comparison metric than total cost may be that of total cost per customer outage avoided (COA), \$/COA. The BCA model Quanta Technology has developed is based on discounted cash flow analysis. The model consists of itemized cash inflows and cash outflows from two different perspectives:

- Utility pretax cash flow: indicates the total cost of the project; often used for budgeting purposes by utilities.
- Revenue requirement: indicates the impact on the ratepayers; often used for seeking regulatory approvals.

Table 8 lists both negative and positive cash flow items for the utility cash flow perspective.

Table 8. Cash Flow Items for Utility Pretax Cash Flow Perspective

Project	Negative Cash Flow	Positive Cash Flow
ESS	ESS CapEx at installed year	Residual value of ESS/interconnection
	ESS interconnection cost at installed year	Annualized market benefits
	ESS/interconnection OpEx	
	ESS/interconnection removal cost	
	T&D Upgrade CapEx at the end of deferral period	
	T&D upgrade OpEx	
Immediate T&D upgrade	T&D upgrade CapEx	N/A
	T&D upgrade OpEx	N/A

The NPV for each project cost is calculated as follows:

- NPV of ESS Cost = NPV of (capital cost + operation cost + removal cost – residual value – annualized market benefit).
- NPV of Immediate Upgrade Cost = NPV of (capital cost + operation cost).

Table 9 lists both negative and positive cash flow items for the revenue requirement perspective.

The NPV for each project cost is calculated as follows:

- NPV of Project Cost = NPV of (operation cost + removal cost + annual book depreciation + property tax – annualized market benefit + ROI).
- ROI = [capital costs – cumulative book depreciation + (Deferral book depreciation – Deferral tax depreciation) × Federal tax] × ROI%.

Table 9. Cash Flow Items for Revenue Requirement Perspective

Project	Negative Cash Flow	Positive Cash Flow
ESS	Annualized ESS and T&D upgrade CapEx ROI	Annualized ESS and T&D upgrade accumulated depreciation ROI
	Annualized ESS and T&D upgrade CapEx depreciation	Annualized market benefits
	Annualized ESS and T&D upgrade OpEx	
	Annualized ESS and T&D upgrade property tax	
	ESS removal cost	
	Annualized deferral tax liability ROI	
Immediate T&D upgrade	Annualized T&D depreciation	N/A
	Annualized T&D OpEx	N/A
	Annualized T&D CapEx ROI	Annualized T&D accumulated depreciation ROI
	Annualized T&D income and property taxes	Annualized deferred tax liability ROI

Figure 23 illustrates different market benefits of an ESS that are captured in annualized market benefits in the BCA model under each of the three scenarios: CD, CDA, and CDAAM. It should be noted that there are inherent energy savings due to peak shaving when the battery is only used for capacity deferral (with no other market participation) that can be passed through to the ratepayer via unaccounted for energy. However, if the battery participates in either the energy market or ancillary service market, there is direct market revenue as settled by the ISO in these markets.

Figure 23. Market Benefit of Energy Storage System

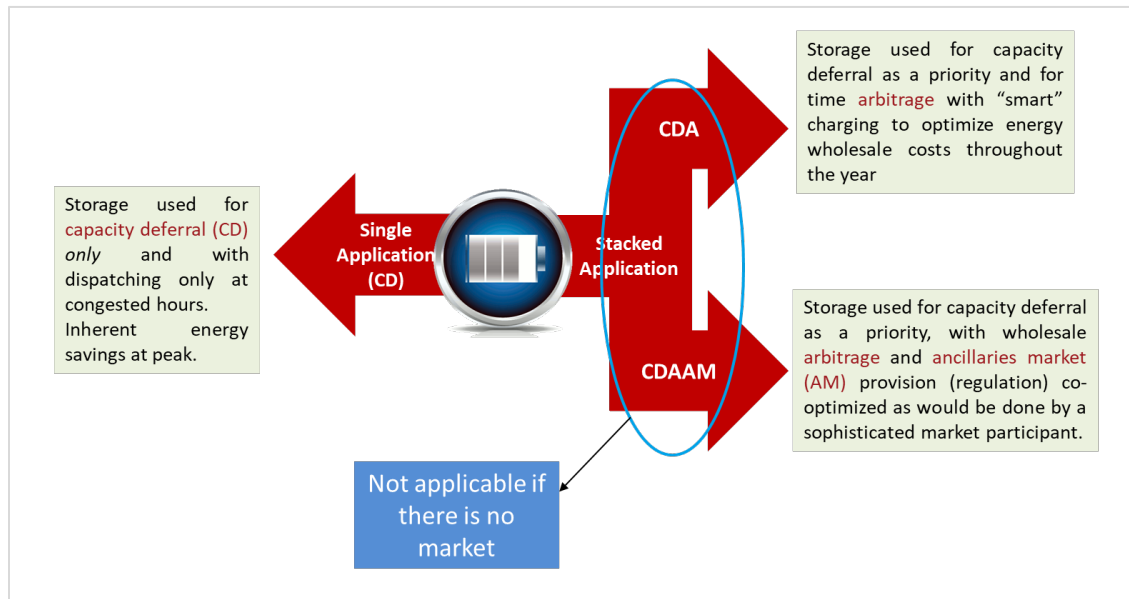

Having an itemized pro forma analysis allows the utility to extract different financial information from the BCA as shown in Figure 24. Apart from single metrics such as NPV of benefits and ROI, the annual financial outlook can be also demonstrated, and different scenarios can be compared side-by-side to assist with a more informed investment decision when it comes to capacity deferral versus immediate T&D upgrade.

Figure 24. Various Revenue Streams of Energy Storage System

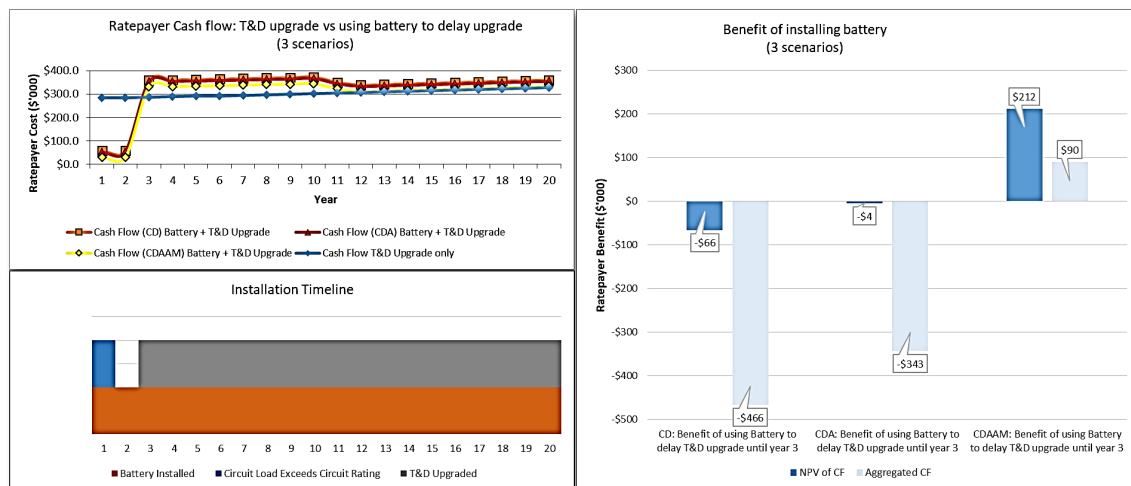

6 Data Requirements

6.1 Energy Storage System Siting and Sizing: Sub-transmission Use Cases

To determine optimal sites and sizes for ESS, the following data are needed:

- Transmission network matrix of PTDFs
- Transmission network matrix of LODFs
- Peak-hour nodal injections
- Peak-hour line power flows
- Shadow prices of binding transmission lines
- Line capacity limits
- ESS efficiency
- Hosting capacity nodal limits on ESS sizes

6.2 Energy Storage System Siting and Sizing: Distribution Use Cases

For the peak-shaving use case, the data required to proceed with ESS sizing (ESS located at the substation) are as follows:

- Substation transformer rating
- Distribution feeder load characteristics (i.e., peak demand and load yearly profile)
- Feeder thermal capacity defined by the utility distribution planning guidelines
- ESS efficiency

For the reliability improvement use case, outage statistics (CAIDI, SAIFI, customer-hour-lost or customer-minute-lost, etc.), outage duration, expected hourly load profile, and ESS efficiency are necessary for sizing the ESS located at the substation. Therefore, the full-feeder model is not necessary for the optimization of the ESS sizes for these two use cases. If the full feeder model is available, the 2.5% distribution loss adjustment that is applied to the ESS size could be refined to the exact loss percentage of each specific distribution system or feeder of interest. However, a full-feeder model *is* needed in the PV integration use case, together with the hourly PV output profile, the expected hourly load profile, and ESS efficiency.

6.3 Non-Energy Storage System Mitigation Solutions

The ESS solution will be compared to traditional investments, the cost of which should be provided by the utility (e.g., T&D planning). The cost information should be detailed and incorporate direct and indirect costs (separated into capital costs, fixed operating costs, variable operating costs, etc.) as required for a cash flow/NPV analysis, which is part of the BCA analysis.

6.4 Stacked Applications

ESS parameters listed previously in Table 4-2 should be the inputs for stacked application analysis. These include ESS efficiency, SOC minimum and maximum, SOC requirement at the beginning and end of the horizon, and variable operation and maintenance.

Further, expected market prices of energy and regulation are required inputs. As mentioned previously, a reasonable estimate of market prices may be hard to obtain; therefore, the projections of market prices are often replaced by an extrapolation based on historical prices of energy and regulation (available on ISOs web pages). For example, the average increase/decrease percentage observed historically for the past three years may be used as a baseline to extrapolate future prices.

7 Distribution System Applications Case: Central Hudson & Electric (CHG&E)

To illustrate the ESS evaluation process as described in the previous sections, this section provides an example of its application in the CHG&E distribution system. This example identifies candidate distribution feeders to evaluate the use of ESS for capacity deferral, reliability improvement, and solar PV integration use cases. The list of identified distribution feeders in this example were discussed with the CHG&E Distribution Planning team to filter those with the current mitigation plan.

7.1 Capacity Deferral

In this section, the screening procedure and its results (i.e., selection of overloaded feeders for potential ESS application), along with ESS sizing for those selected distribution feeders within CHG&E service territory are described. First, the data collection, cleaning, and conditioning steps are explicated. These are followed by screening application and ESS sizing.

7.1.1 Input Data and Assumptions

The study process starts by understanding distribution feeder load characteristics (i.e., peak demand and yearly load profile) and the feeder's thermal capacity defined by the utility distribution planning guidelines. The following data is provided by CHG&E:

- Historical loading at feeder head, 8760-hour (MW or Amps and voltage).
 - CHG&E provided 2016 and 2017 peak load data for 269 distribution feeders.
- Reference year of historical loading.
 - CHG&E provided 2016 and 2017 peak load data.
- Load growth (typically provided as % increase from reference year).
 - Load-growth values reported in CHG&E's 2018 DSIP filing (substation specific) were used.
- Substation capacity (MVA or Amps, based on loading information).
 - Provided by CHG&E as normal and emergency rating in MVAs.
- Years of desired deferral (starting year and duration).
 - Five-year horizon, out to 2023, were assumed.
- Capital cost of traditional (wired) solution.
 - For sake of demonstrating the study methodology, traditional average costs were used.

The forecasted substation load-growth rates are assigned to its associated distribution feeder. To illustrate, Woodstock substation has a 0.7% annual growth rate, in this study the same growth rate (0.7%) is assigned to its corresponding feeders WS_3011, WS_3012, WS_3013, and WS_3014, as shown in Table 10.

Table 10. Feeder Annual Load-Growth Assignment

Substation	Acronym	Feeder Name	Substation Rating (MW)	Growth Rate
Woodstock	WS	WS_3011	20.9	0.7%
Woodstock	WS	WS_3012	20.9	0.7%
Woodstock	WS	WS_3013	20.9	0.7%
Woodstock	WS	WS_3014	20.9	0.7%

7.1.2 Data Cleaning and Conditioning

Distribution load profiles data (in hourly resolution) typically contains data distortion due to temporary spikes or depressions, power outages, load transferring from and to adjacent feeders, temporary switching, or missing data points. Those distortions create artificial peak or light demand points. The data cleaning objective is to identify and remove those abnormal data points and normalize them to avoid misleading results.

Figure 25 shows an example of before and after cleaning load profile curves. The provided 2017 load profile data for feeder BR 4092 (blue line) registered 8.82 MW peak demand, which suggests that it exceeds its design rating by as much as 147% (nominal capacity is 6 MW). By examining the profile, it becomes clear that the event is temporary, and therefore, an outlier. The next peak was registered at over 6 MW, which was also observed to be an isolated event due to temporary load transfer. The actual and validated feeder peak demand is 4.9 MW. The cleaned and conditioned load curve is illustrated in orange in Figure 25.

Figure 25. BR 4091 Time-Series with and without Data Cleaning

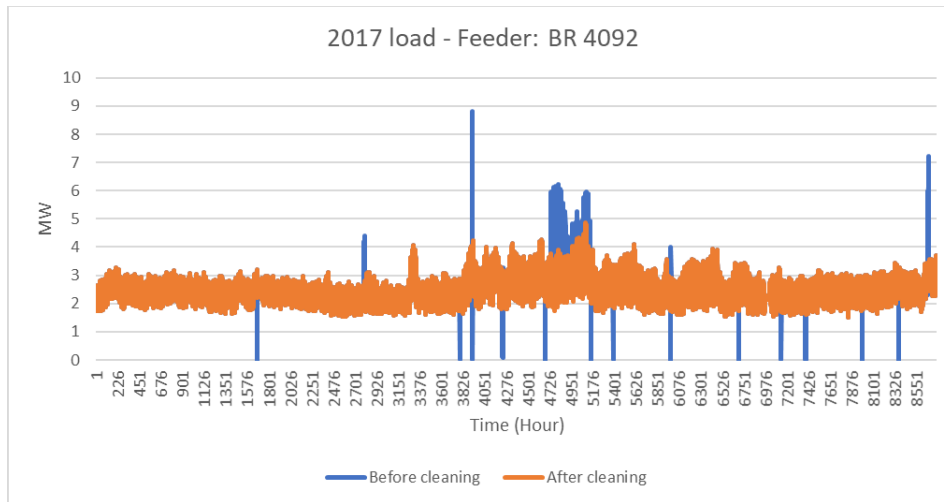

7.1.3 Screening Process

As described in section 2.2.1, after the load profiles data are cleaned and conditioned, the peak demand readings are compared with feeder capacity to determine the overloading index (or utilization factor), based on the power utility distribution planning criteria, weather adjustment factors may be required to scale the circuit peak demand reading. In the current study, the index is calculated applying peak demand forecasted as of 2023. Each overloading factor is then qualified using the capacity deferral tiers, defined in section 2.2.1 (Table 5).

After screening 269 distribution feeders, it is observed that by 2023:

- five feeders fall in Tier 3 (Peak > 100% of normal rating)
- five feeders fall in Tier 2 (95% < loading < 100%)
- sixteen in Tier 1 (90% < loading < 95%)

Figure 26 list all feeders in Tier 3 by 2023. Those will be analyzed to determine the ESS capacity (MW and MWh). Feeder NC-8051 case will be described, as an example, in the following sections.

Figure 26. Selected Feeders (Values in MW)—Tier 3 in 2023 (Peak > 100% of Normal Rating)^a

				Peak	T	Peak	T	Peak	T	Peak	T	Peak	T	Peak	T	Peak	T
MK_5051	6	9	4.10%	4.84	0	5.04	0	5.24	0	5.46	1	5.68	1	5.91	2	6.16	3
MK_5054	6	9	4.10%	5.20	0	5.41	1	5.64	1	5.87	2	6.11	3	6.36	3	6.62	3
ML_7061	6	9	6.10%	4.81	0	5.11	0	5.42	1	5.75	2	6.10	3	6.47	3	6.87	3
NC_8051	6	9	2.00%	5.70	1	5.81	2	5.93	2	6.04	3	6.16	3	6.29	3	6.41	3
TI_8087	6	9	4.70%	5.25	0	5.50	1	5.75	2	6.02	3	6.31	3	6.60	3	6.91	3

^a Ratings included above are CHG&E’s circuit design ratings. These ratings are lower than the thermal limit of the circuit to allow for operational flexibility and longer-term planning.

7.1.4 Energy ESS Siting and Sizing

As a proof of concept of ESS application after a feeder design rating is exceeded, the methodology described in Section 3: Siting and Sizing is applied to CHG&E’s feeder NC_8051 to demonstrate ESS sizing for capacity deferral.

The five-year load growth corresponding to this feeder is 9.8% according to the CHG&E 2018 DSIP filing. This translates to 1.88% annual load growth. The 8760-hr load profile is shown in Figure 27. As shown in Figure 27, the NC_8051 loading exceeds its normal design rating (6 MVA) over the next five years. A closer investigation (Figure 28) shows a selected number of periods in which the design rating is exceeded. ESS could be an alternative solution to conventional grid investments (e.g., three-phase extension and switching for load transfer, reconductoring, etc.).

Figure 27. Hourly Load Profiles for Feeder NC_8051

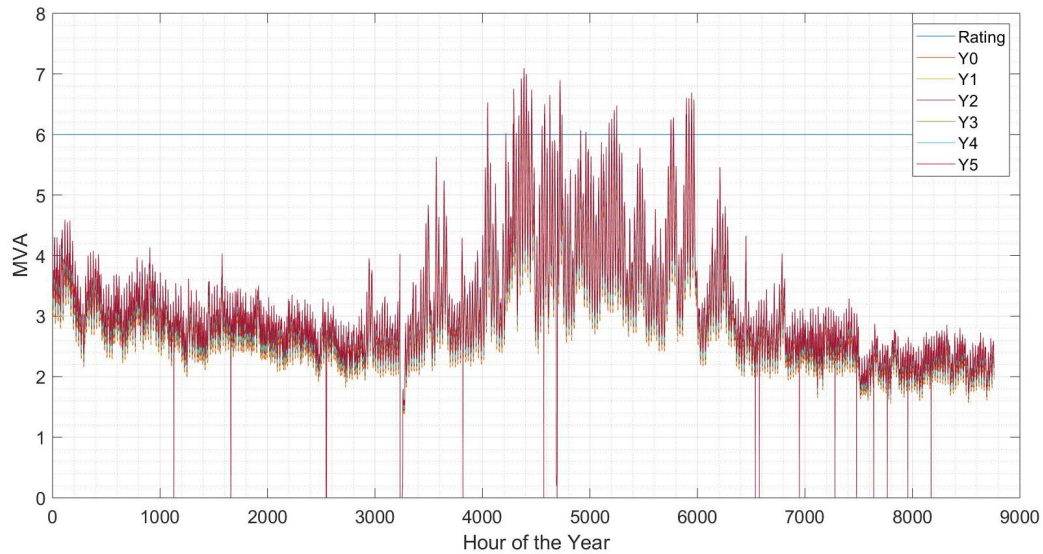
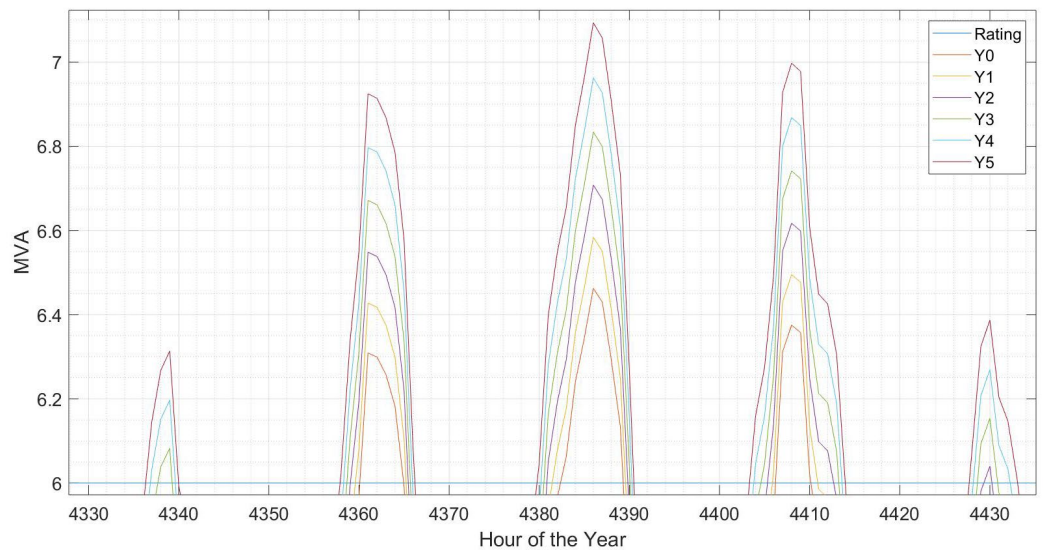

Figure 28. Hours NC_8051 Exceeds Design Rating



Given this loading profile, a 1095 kW/8213 kWh ESS system would be required to cover the load above the 6 MVA design rating by 2023. ESS for this purpose should be on the 13.2 kV side of the substation or near the feeder head of circuit NC_8051.

7.1.5 Benefit-Cost Analysis

As shown in Figure 27 and 28, ESS is only needed for a limited number of hours during the year to ensure the loading remains under the 6 MVA design criteria. To maximize the utilization of ESS—and consequently, its economics—the resource is assumed to participate in NYISO wholesale energy and/or regulation markets. The market participation model optimizes the hourly operation of ESS against the NYISO hourly day-ahead (DA) market prices (LMP in CHG&E zone) considering ESS power and energy ratings as well as its hourly state of charge. In addition, the constraints from the primary application (i.e., capacity deferral) are accounted for in the market participation model to ensure that ESS has enough state of charge to discharge during the hours in which the circuit exceeds its design rating. Table 11 summarizes ESS yearly net revenue under three modes of operation:

1. CD: Capacity deferral only with no additional market participation. In this case, there are some inherent energy savings that can be captured from ESS peak shaving during the periods in which the circuit is operating above its design rating.
2. CDA: Capacity Deferral and Arbitrage in which ESS takes advantage of energy price arbitrage in the DA energy market.
3. CDAAM: Capacity Deferral, Arbitrage, and Ancillary Market in which ESS also participates in the regulation market in addition to the previous case (capacity deferral and energy arbitrage).

It has been shown that stacking both energy arbitrage and regulation benefits can significantly increase the annual revenue of the ESS resource.

Table 11. Energy Storage System Annual Net Benefits

	Year 1	Year 2	Year 3	Year 4	Year 5
CD (\$k)	\$0.096	\$0.126	\$0.159	\$0.145	\$0.150
CDA (\$k)	\$74.78	\$74.65	\$74.48	\$74.30	\$74.12
CDAAM (\$k)	\$156.35	\$156.26	\$156.11	\$155.84	\$155.55

Next, BCA is performed to quantify the net benefit of ESS compared to an immediate T&D upgrade. For this, the rigorous cash flow analysis described in Section 5: Benefit-Cost Analysis Methodology is used. However, in the absence of having specific information on an actual T&D solution and associated costs for this case, Quanta Technology developed a cost-effectiveness curve to show the break-even point for an ESS solution. This analysis is based on ESS and financial assumptions listed in Table 12 and Table 13.

Table 12. ESS Cost Assumptions

Parameter	Value	Source
ESS cost (\$K/MWh)	\$490	Quanta Technology
Interconnection cost (\$K/MW)	\$110	NREL
Annual reduction in ESS cost	4%	Quanta Technology

Table 13. Financial Parameters

Parameter	Value
CAPEX ROI	5.50%
Federal Tax Rate	21.00%
% Equity	51.3%
% Long-term Debt	45.4%
% Short-term Debt	3.3%
Cost of Equity	10.75%
Cost of Long-term Debt	4.450%
Cost of Short-term Debt	2.6%
WACC	7.6200%
WACC - Pre Tax	9.50%
Inflation rate	2.2%
Battery MW cost for Static Case \$k/MW	\$0
Battery MWh cost for Static Case \$k/MWh	\$490
Battery MW cost for Mobile Case \$k/MW	\$0
Battery MWh cost for Mobile Case \$k/MWh	\$389
Battery cost reduction	4.0%
Opex on Battery	3%
Battery depreciation / yr	10.0%
Maximum number of years upgrade is delayed	5
Remove battery when upgrade is installed	Yes
Disassembly cost - Static Battery \$k/MWh	\$9
Wrapping & moving cost - Static Battery \$k/MWh	\$4
Moving Cost of the trailer - Mobile Battery \$k/MWh	\$11
Removal cost Multiplier	100%
Opex on Interconnection	3%
Remove Interconnection when upgrade is installed	Yes
<i>T&D Cost – Battery - \$K/MW</i>	\$110
Opex on T&D Upgrade	3.2%
T&D depreciation / yr	3.0%
Efficiency	96%
Initial State of Charge (SOC)	50%
Minimum allowable SOC	5%
Maximum allowable SOC	100%

We performed the BCA from two different perspectives: (1) revenue requirement, which quantifies the ratepayer’s impact and (2) pretax cash flow, which compares the net cost of ESS and immediate upgrade for utility.

Figure 29 shows at what cost point, an ESS solution would result in cost savings for the ratepayers under each ESS operating mode.

Figure 29. Revenue Requirement for Upfront Energy Storage System Installation Compared to Transmission and Distribution Upgrade Costs

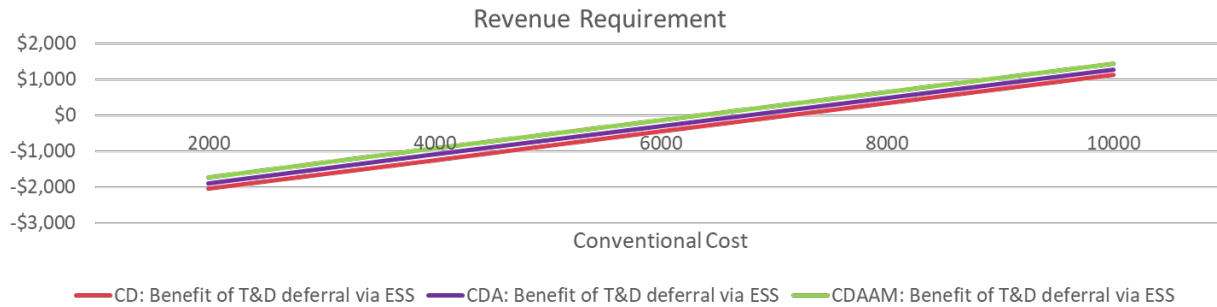

Using the ESS size determined in the previous section and the financial parameters listed previously, our analysis shows that if ESS can monetize all market benefits, it would be a cost-effective alternative for any immediate T&D upgrade that costs more than \$6.2 million, considering CDAAM mode of operation. This break-even point increases if ESS market benefits reduce (summarized in the Table 14). In other words, if the T&D upgrade is lower than \$6.2 million (considering CDAAM mode of operation), then ESS is not cost-effective.

Table 14. Break-Even Cost at Different Mode of Operation (Ratepayer)

Scenario	Cost (\$k)
CD	\$6,990
CDA	\$6,620
CDAAM	\$6,200

A similar analysis is performed from a utility’s perspective, and the results are shown in Figure 30 and Table 15. It is shown that, from a purely cost perspective, ESS would be cost-effective for any immediate T&D upgrade that is more expensive than \$8.3 million if all market benefits are realized. Or, if the T&D upgrade cost is lower than \$8.3 million, then ESS will not be cost-effective.

Figure 30. Pretax Cash Flow for Upfront Energy Storage System Installation Compared to Transmission and Distribution Upgrade Costs

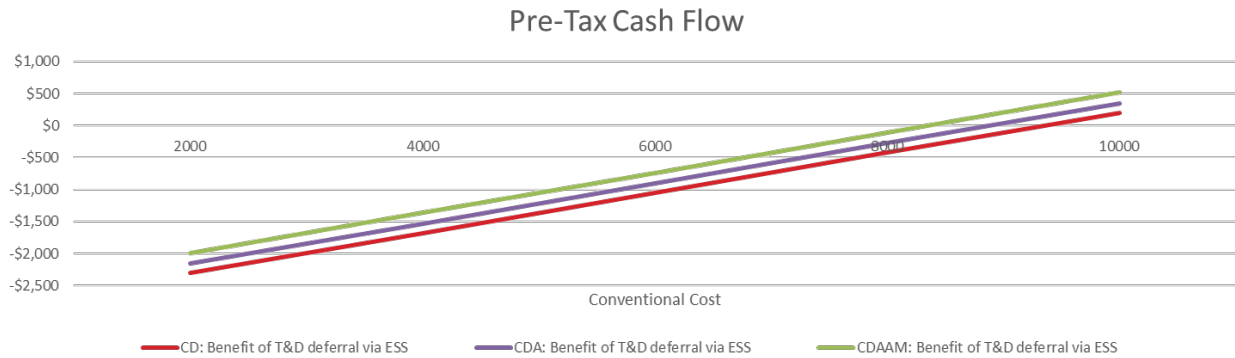

Table 15. Break-Even Cost at Different Mode of Operation (Utility)

Scenario	Cost (\$k)
CD	\$9360
CDA	\$8880
CDAAM	\$8330

7.2 Reliability Improvement

The objective is to identify potential distribution feeders or feeder sections to deploy ESS in order to improve its reliability performance. Section 2.2.2 describes the two-step screening process. The first ranks the worst-performing feeders followed by performing outage root cause analysis to identify feeders for potential ESS applications.

7.2.1 Input Data and Assumptions

Quanta Technology screened the provided distribution feeders (see methodology) to narrow them down to feeders that should be examined for reliability applications. The enumerated data request items are as follows:

- Outage duration.
 - CHG&E provided reliability indices CAIDI, SAIFI for 269 distribution feeders.
- 8760-hour historical load in part of feeder impacted/islanded by outage (MW). Alternatively, the substation 8760-hour loading and the line on outage can be provided to approximate the 8760-hour historical load in part of feeder impacted/islanded by outage.
 - CHG&E provided load profiles data.

- Reference year of historical loading.
 - CHG&E provided 2016 and 2017 peak load data.
- Load growth (typically provided as % increase from reference year).
 - Load-growth values reported in CHG&E's 2018 DSIP filing (substation specific) were used.
- Years of desired reliability improvement (starting year and duration).
 - It was assumed 5-year horizon, out to 2023.
- Capital cost of traditional (wired) solution.
 - For demonstrating the study methodology, traditional costs were used.

7.2.2 First Screening Process

Feeder’s reliability performance index (RPI) is calculated for 269 feeders. As described in Section 2.2.2: Reliability Improvement, the RPI is a weighted standard reliability metric, in the case of CHG&E the following reliability indexes and weighting factors are applied:

- SAIFI weight 30%
- CAIDI weight 30%
- CELID weight 10%
- C-M weight 30%

Table 16 lists the nine feeders with the highest RPI indexes. Some utilities qualify them as the worst-performing feeders from a reliability perspective.

Table 16. Ranking of Feeders Based on Reliability Performance Index

Feeder ID	Served Customers	SAIFI (Normalized)	CAIDI (Normalized)	CELID (Normalized)	C-M (Normalized)	Weighted Average of Normalized parameters (WNP)	Ranked RPI
WS_3012	3057	0.549	0.301	1.000	1.000	0.6551	1
NS_3091	1774	0.810	0.400	0.425	0.547	0.5695	2
WS_3011	1807	0.491	0.276	0.688	0.603	0.4796	3
BV_1011	1595	0.788	0.239	0.591	0.357	0.4745	4
HA_2094	2513	0.570	0.368	0.375	0.361	0.4273	5
WS_3013	1832	0.592	0.233	0.430	0.287	0.3765	6
KH_3082	2174	0.225	0.581	0.489	0.254	0.3668	7
SG_3003	2274	0.579	0.257	0.419	0.213	0.3565	8
HI_3024	2379	0.388	0.351	0.495	0.272	0.3528	9

7.2.3 Second Screening Process

From the list in Table 16, radial feeders with no field tie and/or feeder section with difficult access during power outage conditions are required to be identified. For the purposes of the example feeder WS_3012, the following characteristics have been selected:

- Long, radial feeders with limited-to-no capacity to transfer load.
- Feeders with limited or difficult access for field crews during restoration efforts.

7.2.4 Energy Storage System Siting and Sizing

The methodology described in section 3 is applied to feeder WS_3012 to demonstrate how ESS is sized to improve local reliability using a real-world example.

Based on load data provided by CHG&E, the peak load experiences growth forecasting reaching 9.3 MW for 2023. The reliability analysis of feeder sections identified a single-phase section downstream of switch 103856 as the most vulnerable section with no backup option during outages (see Figure 31). The feeder section peak is estimated to be 1.2 MW (13% of feeder peak). The load profile of the feeder section for peak day in 2018 is illustrated in Figure 32. ESS is required to back up the feeder section impacted by multiple outages located upstream. Using a four-hour rolling window, the ESS energy requirement on the peak day is shown in Figure 33. According to these requirements until 2023, a 1200 kW/4900 kWh ESS is needed to improve the reliability of this feeder section.

Figure 31. Representation of Feeder WS-3012 in a Single Line Diagram

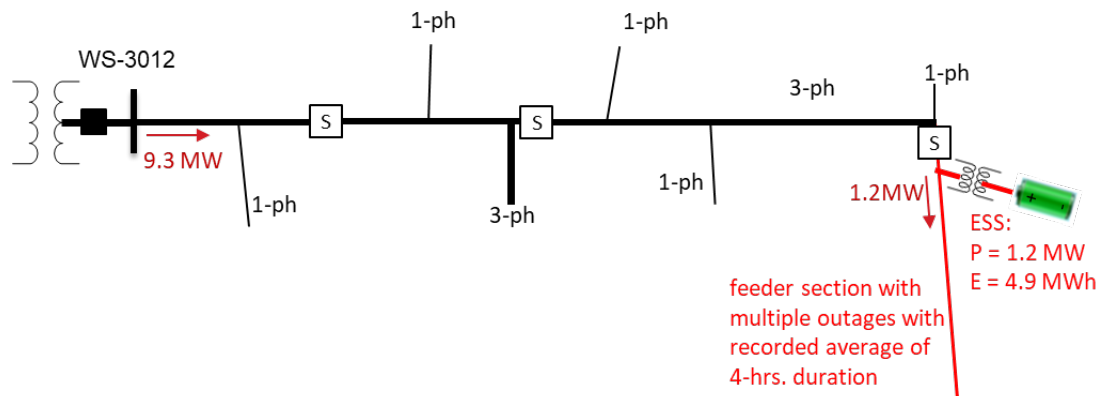

Figure 32. Peak-Day Load in 2018

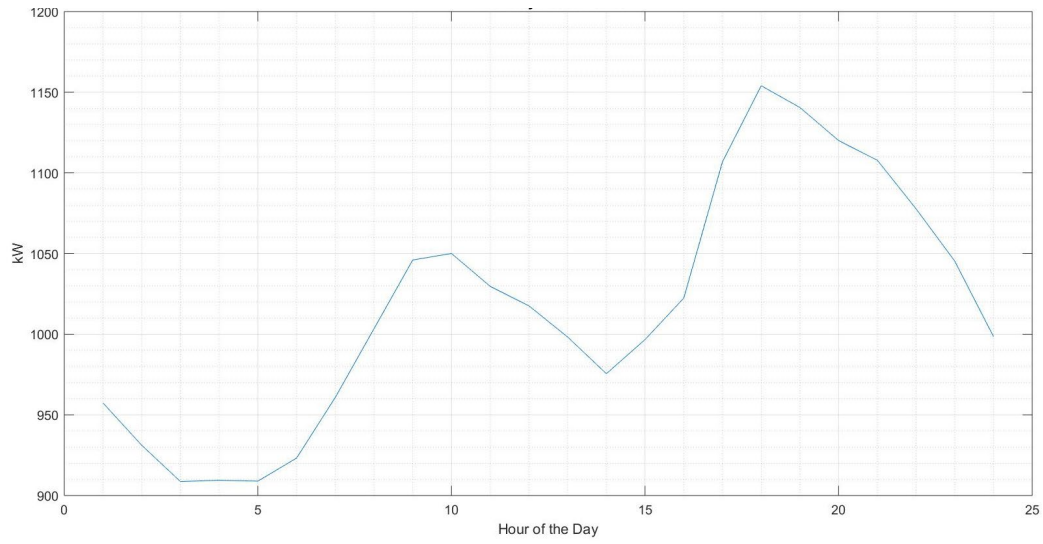
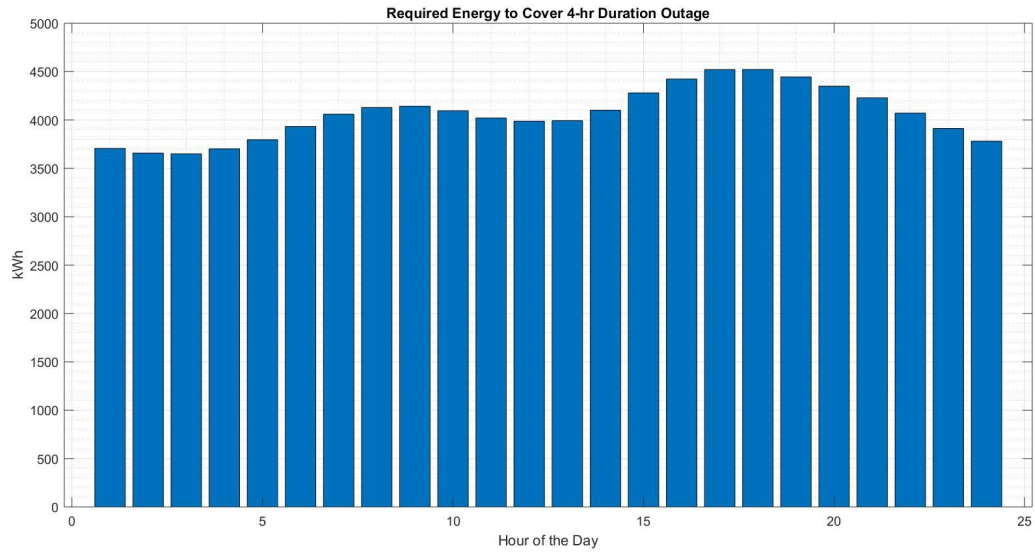

Figure 33. Energy Storage System Energy Requirement on Peak Day



7.2.5 Benefit-Cost Analysis

Similar BCA analysis as in the capacity deferral example is performed for this feeder. The Table 17 summarizes the net annual benefit of ESS under three different operating modes (CD, CDA, CDAAM).

The break-even points from a ratepayer’s perspective would be for immediate T&D projects more than \$3.5 million if the ESS participates in both the energy and regulation market. This threshold increases to \$4.7 million from a utility’s cash flow perspective comparing the net cost of ESS and wires solutions, as shown in Table 17, Table 18, Table 19, Figure 34, and Figure 35.

Table 17. Energy Storage System Annual Net Benefit

	Year 1	Year 2	Year 3	Year 4	Year 5
CD (\$k)	\$0.099	\$0.100	\$0.101	\$0.101	\$0.102
CDA (\$k)	\$47.95	\$48.34	\$48.71	\$48.40	\$48.77
CDAAM (\$k)	\$150.93	\$151.27	\$151.60	\$151.26	\$151.59

Figure 34. Revenue Requirement for Upfront Energy Storage System Installation Compared to Transmission and Distribution Upgrade Costs

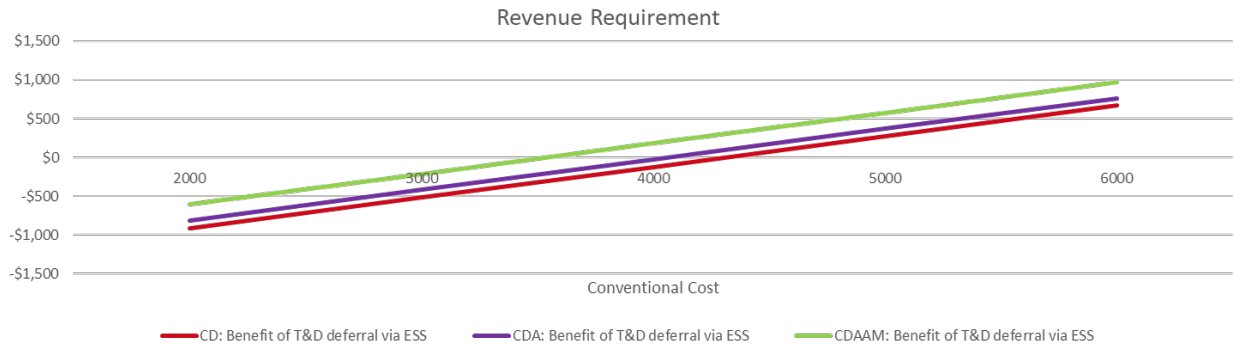

Table 18. Break-Even Cost at Different Mode of Operation (Ratepayer)

Scenario	Cost (\$k)
CD	\$4310
CDA	\$4060
CDAAM	\$3540

Figure 35. Pretax Cash Flow for Upfront Energy Storage System Installation Compared to Transmission and Distribution Upgrade Costs

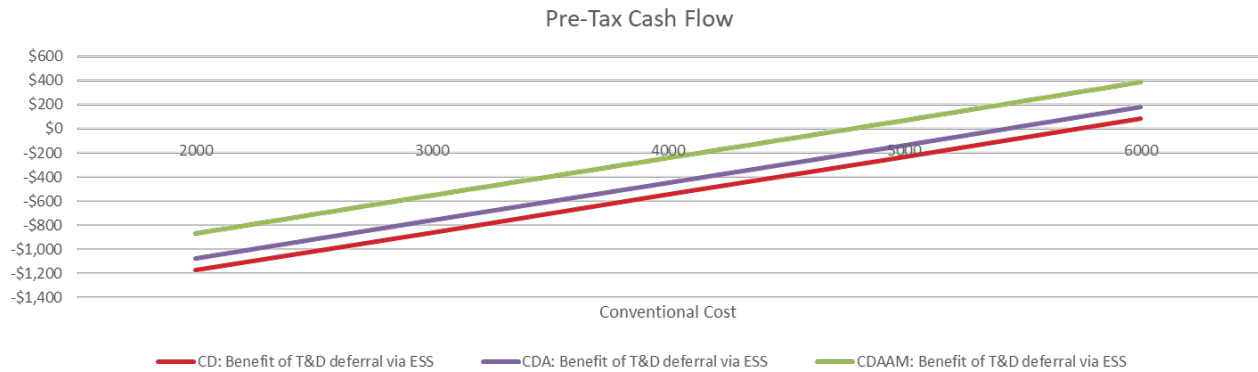

Table 19. Break-Even Cost at Different Mode of Operation (Utility)

Scenario	Cost (\$k)
CD	\$5740
CDA	\$5430
CDAAM	\$4690

7.3 Renewable Integration

As described in section 2.2.3, if a utility has already conducted hosting capacity analysis, it can be used to identify feeders that have an expected total DG capacity (interconnected and queued) that will exceed the estimated hosting capacity. If hosting capacity analysis has not been conducted, statistical clustering analysis can be used to select distribution feeders.

7.3.1 Input Data and Assumptions

The following are required data:

- Converged power flow model of distribution feeder of interest (e.g., CYME, Synergi, MilSoft) without loops.
 - CHG&E provided Feeder power flow models in MilSoft.
- Renewable location, size and type, and interconnection date.
 - From the screened list, CHG&E selected feeders to be studied.
- 8760-hour historical feeder load (MW or Amps, based on availability, can also be calculated if the voltage is known).
 - CHG&E provided 2016 and 2017 peak load data.

- Reference year of historical loading.
 - 2016 and 2017 loading data were processed.
- 8760-hr profile of renewable generation output.
 - CHG&E provided solar PV production profiles of those feeders selected for study.
- Load growth (typically provided as % increase from reference year).
 - Load-growth values reported in CHG&E's 2018 DSIP filing (substation specific) were used.
- Years of desired mitigation (starting year and duration).
 - It was defined as the year where voltage issues started occurring.
- Capital cost of traditional (wired) solution.
 - For demonstrating the study methodology, traditional costs were used.

7.3.2 Screening Process

CHG&E had already completed hosting capacity analysis for the three-phase circuitry for distribution circuits emanating from a substation at 12 kV and above. Using CHG&E's hosting capacity data as well as existing and queue information, feeders with a low hosting capacity range, higher PV capacity in service or in the queue were identified. Based on these criteria, distribution planning identified MO_5011 as the feeder to use to evaluate siting, sizing, and BCA analysis.

7.3.3 Energy Storage System Siting and Sizing

The methodology described in Section 3: Siting and Sizing is applied to feeder MO_5011 to demonstrate how ESS is sized to support renewable integration by mitigating overvoltage issues caused by a renewable source. It was identified and simulated as 2 MW of solar PV on this feeder. In this example, only overvoltage issues (based on ANSI standard) are mitigated. Other issues such as flicker and backfeed are not analyzed. Flicker and reverse power flow should be included based on utility-defined criteria and limits.

This feeder experiences overvoltage with high penetration of PV. ESS is deployed to counter the rise in voltage from the PV. A lesser amount of ESS was needed once it was sited closer to the voltage violation. Also, dispatching reactive power is more effective than dispatching real power for correcting the voltage violation. When the PV is not generating, the ESS discharges back into the grid to compensate for the loss of PV output. ESS hourly charge and discharge against PV generation is shown in Figure 36. Based on these requirements, a 200 kW/450 kWh ESS is required for this application.

Figure 36. Energy Storage System Hourly Operation to Mitigate Overvoltage Violation with Increased PV Levels

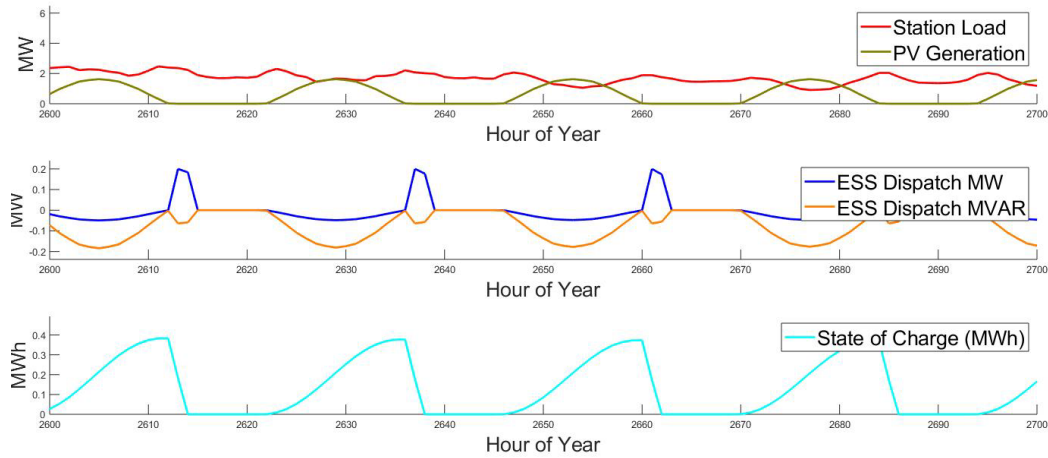

7.3.4 Benefit-Cost Analysis

Assuming similar loading and PV penetration conditions over future years, market participation was simulated for one year for this case and summarized in Table 20.

Table 20. Energy Storage System Annual Net Benefit

Scenario	Year 1
CDA (\$k)	\$7.58
CDAAM (\$k)	\$24.43

Assuming the ESS can take advantage of revenue from both energy and regulation markets, the BCA analysis shows that ESS would be a cost-effective alternative for any immediate upgrade larger than \$310,000 associated only with mitigating overvoltage. From a utility’s cash flow perspective, this threshold would be \$415,000 comparing the net cost of ESS and wires solutions, as shown in Figure 38, Figure 21, Figure 38, and Table 22.

Figure 37. Revenue Requirement for Upfront Energy Storage System Installation Compared to Transmission and Distribution Upgrade Costs

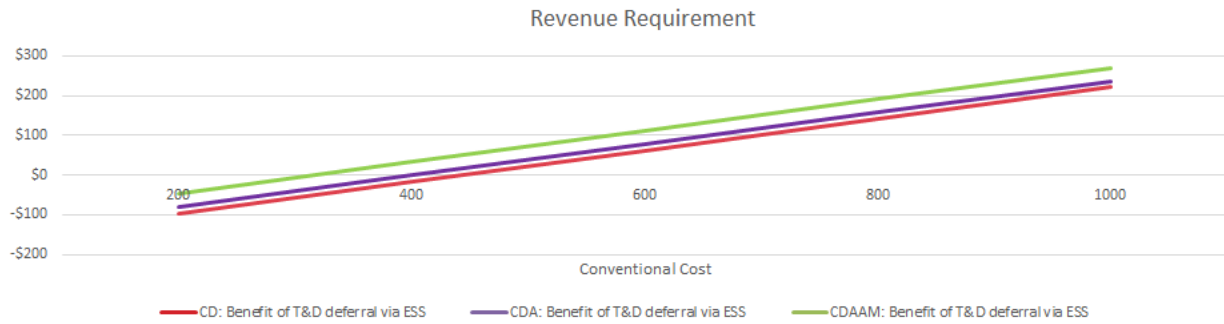

Table 21. Break-Even Cost at Different Mode of Operation (Ratepayer)

Scenario	Cost (\$k)
CD	\$430
CDA	\$395
CDAAM	\$310

Figure 38. Pretax Cash Flow for Upfront Energy Storage System Installation Compared to Transmission and Distribution Upgrade Costs

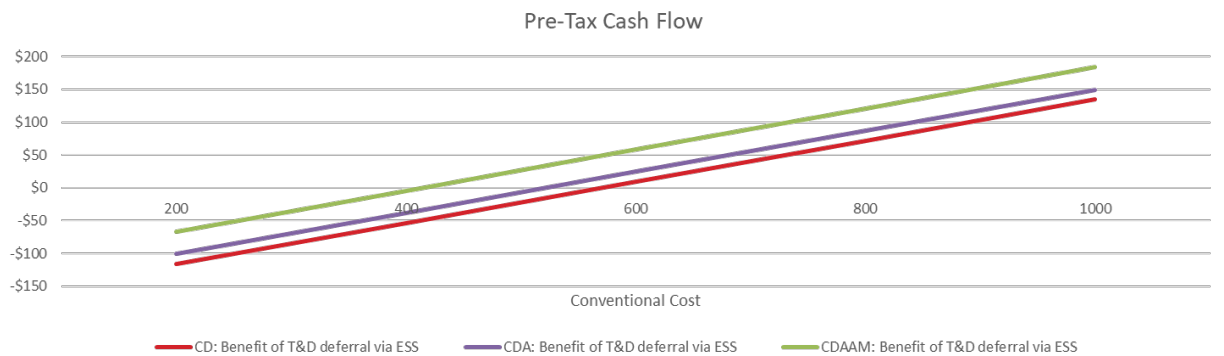

Table 22. Break-Even Cost at Different Mode of Operation (Utility)

Scenario	Cost (\$k)
CD	\$570
CDA	\$525
CDAAM	\$415

8 Transmission System Applications

Case: Central Hudson Gas & Electric

This section provides an example of ESS evaluation in the Central Hudson Gas & Electric (CHG&E) transmission system. The examples first identify sub-transmission system elements or conditions where ESS could be an option to enhance operations, followed by a discussion of siting and sizing ESS and evaluating the BCA. The following use cases are evaluated:

- Mitigation of the local impact of renewable integration
- Management of congestion
- Capacity deferral

The list of system elements in this example was discussed with the CHG&E Planning team to filter those with current mitigation plans.

8.1 Mitigation of Local Impact of Renewable Integration

8.1.1 Input Data and Assumptions

The following inputs from the CHG&E provided material were pertinent to this use case:

Converged PSSE model of 2018 summer peak study case.

1. Renewable location, size and type, and interconnection date from the NYISO interconnection queue.
2. 8760-hour historical load and forecasted peak (MWs) available in CHG&E's GIS portal.
3. 8760-hour renewable output shape (in percent of capacity) obtained for the appropriate CHG&E areas from NREL's tool, PVwatts.com

The capital cost of a traditional (wires) solution is considered sensitive information; therefore, the following assumptions were made:

- Deferral period/desired mitigation is five years.
- Battery storage financials were analyzed using traditional cost as a variable.

8.1.2 Screening Process

The screening study methodology, described in a previous section, is applied to the CHG&E service territory. The NYISO interconnection queue includes no thermal units in the CHG&E system, a solid waste facility, three energy storage interconnections, and various solar interconnections. Table 23 provides details of the solar PV interconnections capacity and location requirements.

Table 23. Solar PV interconnection Capacity and Location

Project Name	Capacity (MW)	County	Interconnection Point	Online Date ⁹
Greene County I	20	Greene, NY	Coxsackie - North Catskill 69 kV	2019/06
Greene County II	10	Greene, NY	Coxsackie Substation 13.8 kV	2019/06
Greene County Energy	20	Greene, NY	New Baltimore - Coxsackie 69 kV	2018/08
Greene County III	20	Greene, NY	North Catskill - Coxsackie 69 kV	2020/06
Saugerties Solar	20	Ulster, NY	Saugerties 69 kV	2019
Sunset Hill Solar	20	Albany, NY	New Baltimore - Westerlo NW 69 kV	2020/08
Magruder Solar	20	Ulster, NY	East Walden - Modena 115kV	2020/12
Gedney Hill Solar	20	Albany, NY	New Baltimore - Westerlo 69kV	2020/04

Furthermore, the Standardized Interconnection Requirements (SIR) queue includes 184,242 kW of proposed additional generation in CHG&E. Of these, 184,235 kW are from solar projects. The TSO queue for additions to CHG&E was not examined.

The study year 2023 was selected, assuming all renewables listed in Table 24 in the NYISO queue will be operational. Solar irradiation profiles for Greene, Albany and Ulster counties were obtained from the NREL PVwatts tool.¹⁰ Figure 39, Figure 40, and Figure 41 present simulation results of the 8760-hour power output profiles of a 70-MW, 40-MW, and 40-MW solar PV generation in each county (Greene, Albany, and Ulster, respectively).

Figure 39. 70-MW Solar PV Power Output Yearly Profile—Greene County

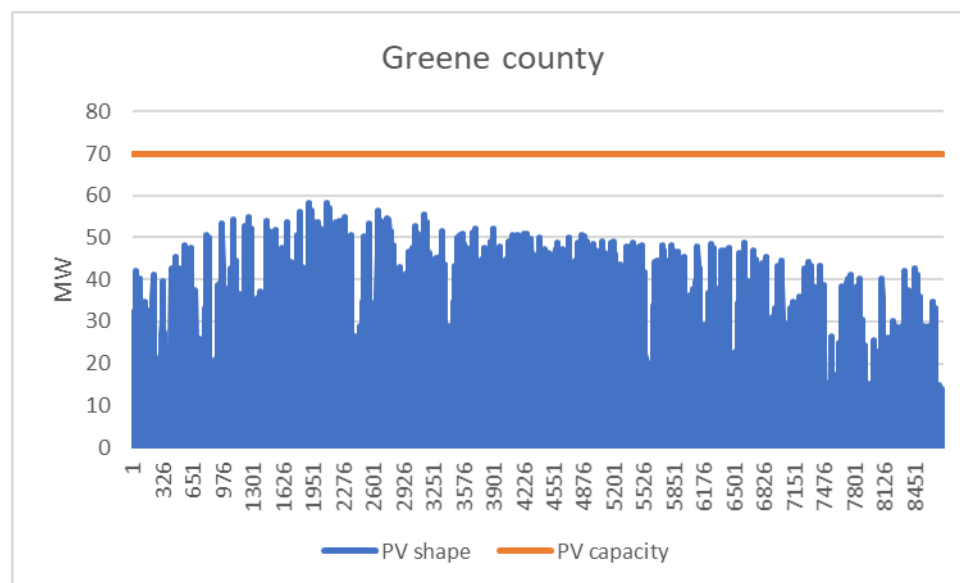

Figure 40. 20-MW Solar PV Power Output Yearly Profile—Sunset Hill Solar, Albany County

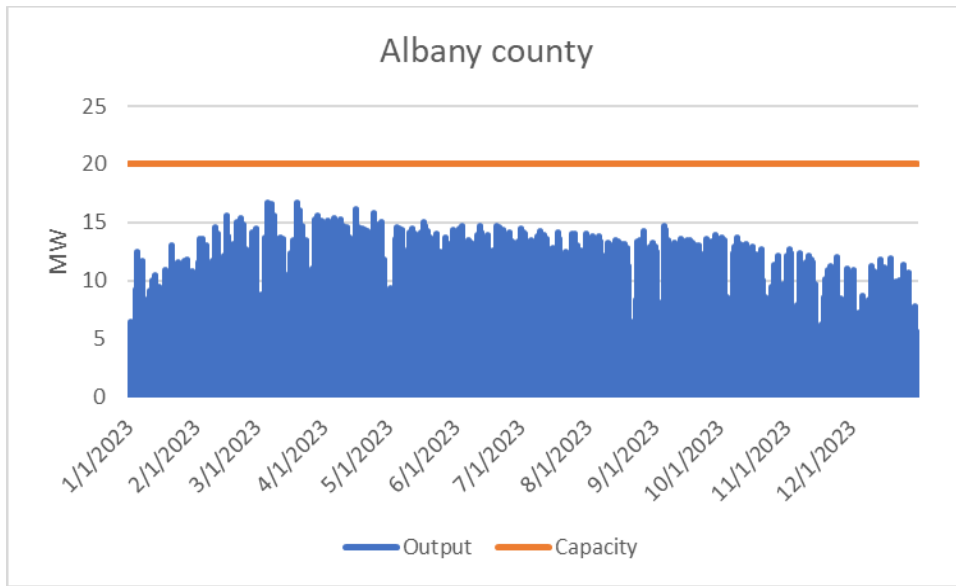
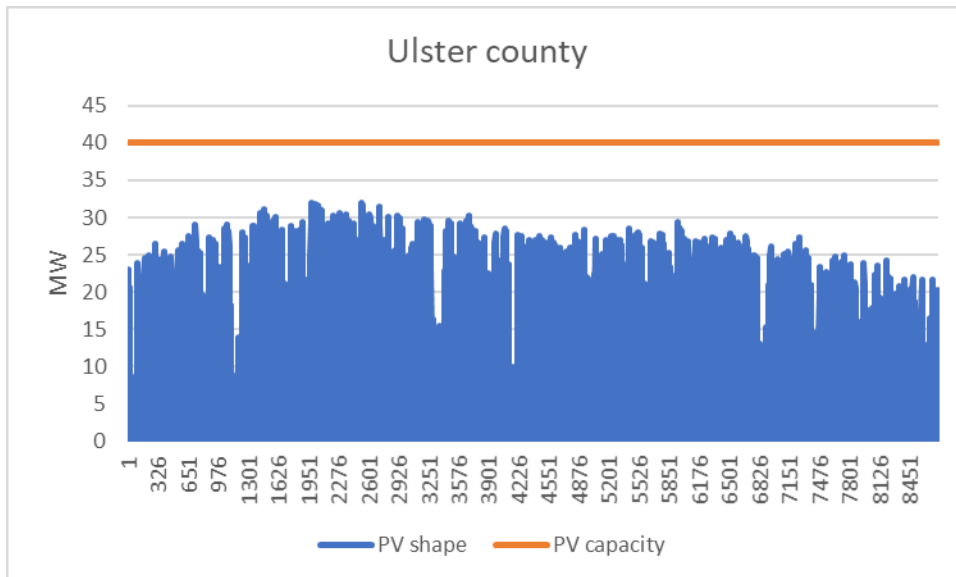

Figure 41. 40-MW Solar PV Power Output Yearly Profile—Ulster County



Seventy MW (70 MW) of total solar PV located in Greene County were assumed to be interconnected to the Coxsackie 69kV node (125093), 40 MW total solar PV located in Albany County was assumed to be interconnected to the Westerlo 69kV node (125144), and 40 MW of solar PV located in Ulster County were assumed to be interconnected to the East Walden 115 kV node (125024) and the Saugerties 69kV node (125126).

All thermal generators due to be online by 2023 in Zone G per the most recent Gold Book are added. No thermal generation retirements are expected in Zone G. Peak load forecast for 2023, also from Gold Book data, together with the 8760-load shape of the actual 2018 loads were used. Figure 42 presents the 8760 loads in Zone G in 2018, normalized as a percentage of the peak load (i.e., peak load of 2018 in Zone G).

Figure 42. 2018 Zone G Yearly Load Profile

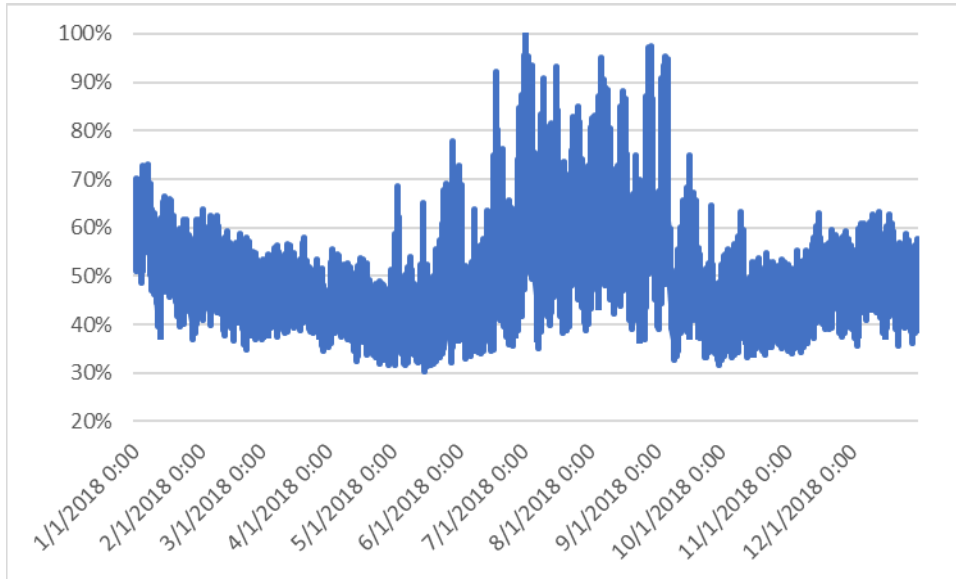

A worst-case scenario analysis was performed where the maximum of the PV output is added to the PSSE base case. For this case, the 69kV Cossackie–North Catskill line is loaded at 81.41 MVA; 16.3% above the line’s designed normal capacity of 70 MVA.

8.1.3 Energy Storage Siting

The only buses that have a non-zero PTDF, and are potential storage siting locations, are Cossackie 69kV (125093), New Baltimore 69kV (125115), and Westerlo NW 69kV (125145). All three of these locations are electrically equivalent and have a unity PTDF with respect to the overloaded Cossackie–N. Catskill line.

8.1.4 Energy Storage Sizing

Storage sizing for this use case is typically determined through the solution of a linear optimization problem. The constraints are minimum and maximum bounds on the battery size, power balance constraints (battery output will be offset by the substation), as well as constraints on the power

flow on the monitored lines after the dispatch of storage is lower than the line’s limit. In effect, this case, there is one potential location, since all three buses have the same PTDF of 1. A PTDF of unity means that an injection at this node will yield an exactly equal flow reduction at the overloaded line. Therefore, the needed battery size at Cocksackie 69kV (or electrically equivalent locations New Baltimore 69kV and Westerlo NW 69kV) is 11.41 MW. Based on the 8760-hour Zone G load profile, the battery energy capacity needed is 73.3 MWh.

8.1.5 Benefit-Cost Analysis

For the Benefit-Cost Analysis results in this section, battery energy storage is assumed to not participate in the energy or ancillary markets. For lack of explicit cost information, the analysis was performed with the traditional investment as a variable, as seen in Figure 43. Please note that cases with market participation aside, the nodal location of the storage is not an impactful parameter/input in the BCA analysis.

For the BCA analysis, the MWh requirement of the battery for renewable integration applications is based on a two-hour duration assumption. Figure 43 shows the pretax cash flow and the revenue requirement versus the traditional investment for the battery size of 11.41 MW/73.3 MWh. The revenue requirement can be interpreted as a ratepayer’s perspective focused analysis, while the pretax cash flow would be a utility perspective focus. The investment in the battery is financially competitive from a revenue requirement perspective for a traditional investment higher than \$64.24 million and is financially competitive from a utility (pretax cash flow) when the traditional investment is higher than \$83.83 million.

Figure 43. Revenue Requirement (Ratepayer) and Pretax Cash (Utility) Flow: Cocksackie 69kV

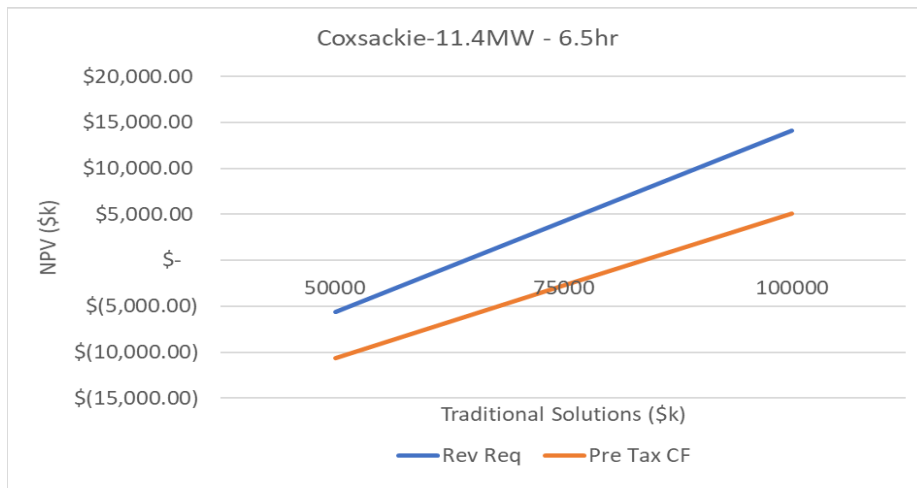

8.2 Management of Load and Congestion Relief

8.2.1 Input Data and Assumptions

The following inputs were used:

1. Quanta Technology’s proprietary NYISO production cost model solution.
2. Converged PSSE model of 2018 summer peak study case updated for 2023.
3. 8760-hour historical load and forecasted peak (MWs) available in CHG&E’s GIS portal.

The capital cost of a traditional (wired) solution is considered sensitive information, therefore, the following assumptions were made:

- Deferral period/desired mitigation is five years
- Battery storage financials were analyzed using the traditional cost as a variable.

8.2.2 Screening Process

NYISO congestion is determined using GridView modeling software. In particular, the NY market model for the year 2023 is used, including complete 2023 load information, generator addition information, and generator retirement information from the 2017 Gold Book. Table 24 elaborates on the non-coincident summer peak energy used.

Table 24. Annual Energy (MWh) per Zone

Zone	2023 CARIS (MWh)
Zone A - West	15,419
Zone B - Genessee	9,643
Zone C - Central	15,979
Zone D - North	4,488
Zone E - Mohawk Valley	7,824
Zone F - Capital	12,478
Zone G - Hudson Valley	9,537
Zone H - Millwood	2,755
Zone I - Dunwoodie	5,906
Zone J - NY City	50,903
Zone K - L Island	20,366
TOTAL	155,298

Fuel prices used also correspond to 2023 fuel price forecasts in the latest CARIS report (Congestion Assessment and Resource Integration Study).

Further, external interface flows are modeled as generators with fixed profiles. These profiles are built using the five-minute 2017 interface flows, available on the NYISO website, averaged to the hour. For reference, Table 25 and Figure 44 through Figure 45 show the interface flows on HQ, Ontario, PJM-NYISO, and ISONE-NYISO.¹¹ Figure 46 shows the cumulative sum of CSC, Norwalk, VFT, and HTP interfaces.

Table 25. Interface Total Annual Power Flow Result (Year 2017)

System	2017 Actual Flows (GWh)
HQ Total	11,620
Ontario	8,233
PJM-NYISO	2,327
ISONE-NYISO	-3,880
CSC+Norwalk+HTP+Neptune+VFT	8,466
TOTAL	26,766

Figure 44. HQ Interface Flow Profile

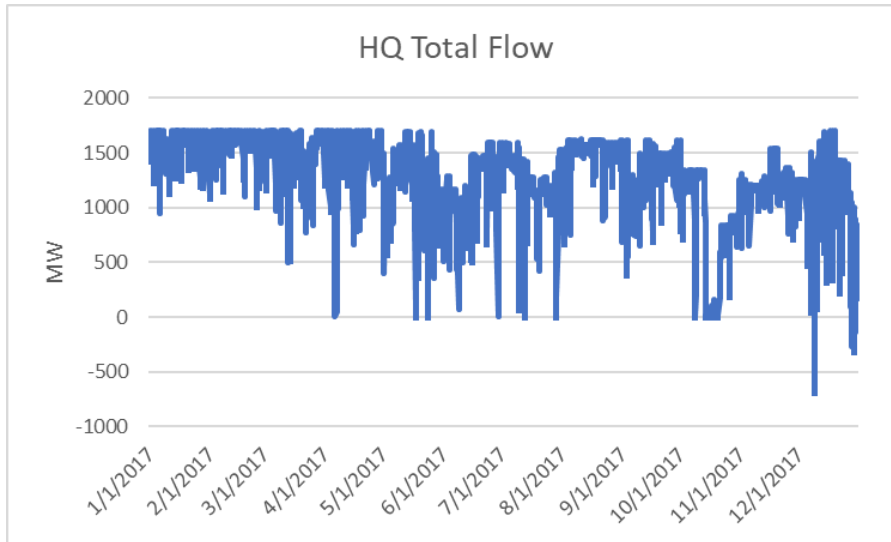

Figure 45. Ontario Interface Flow Profile

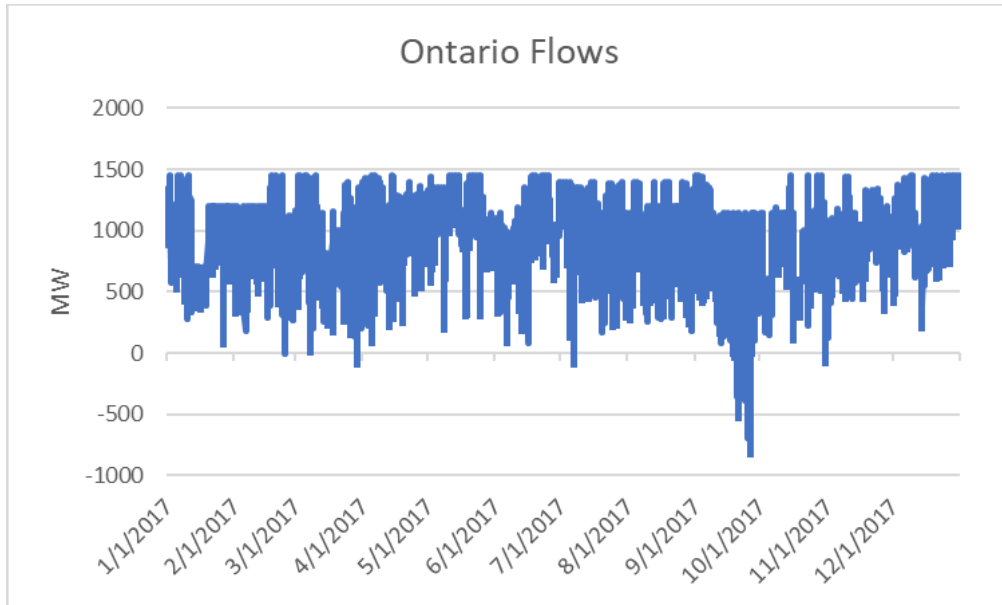

Figure 46. PJM-NYISO Interface Flow Profile

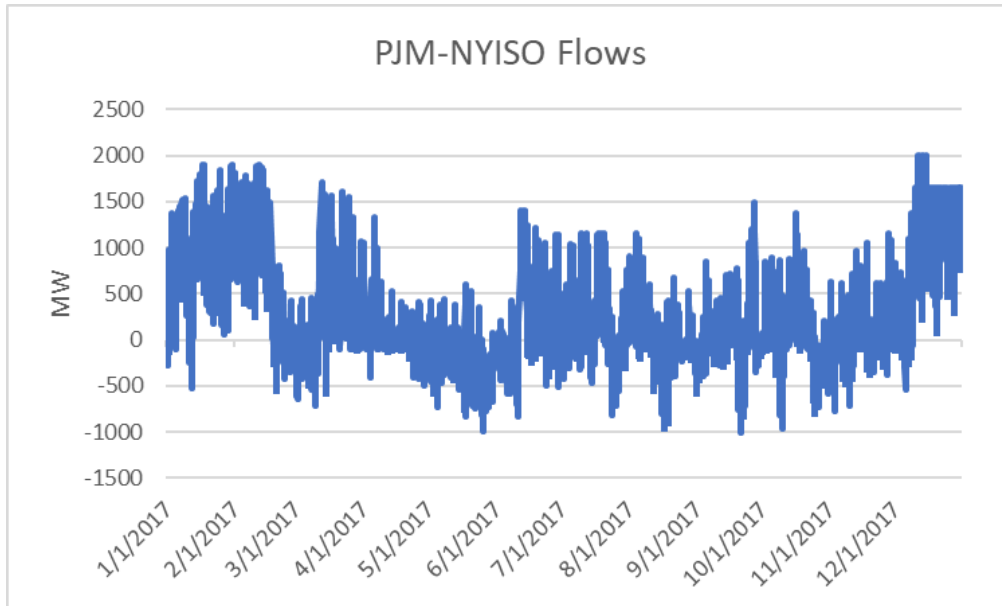

Figure 47. ISONE-NYISO Interface Flow Profile

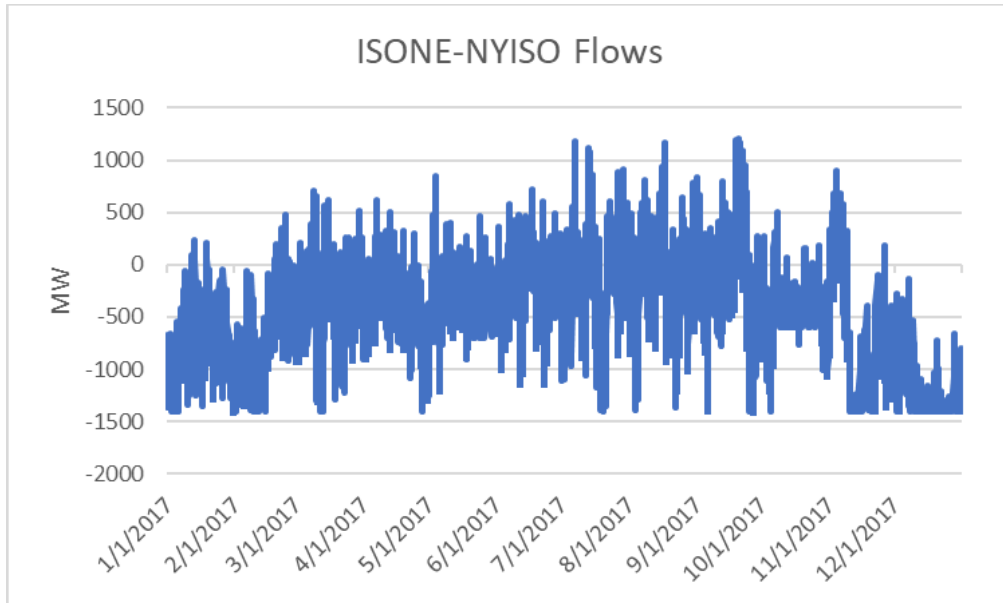
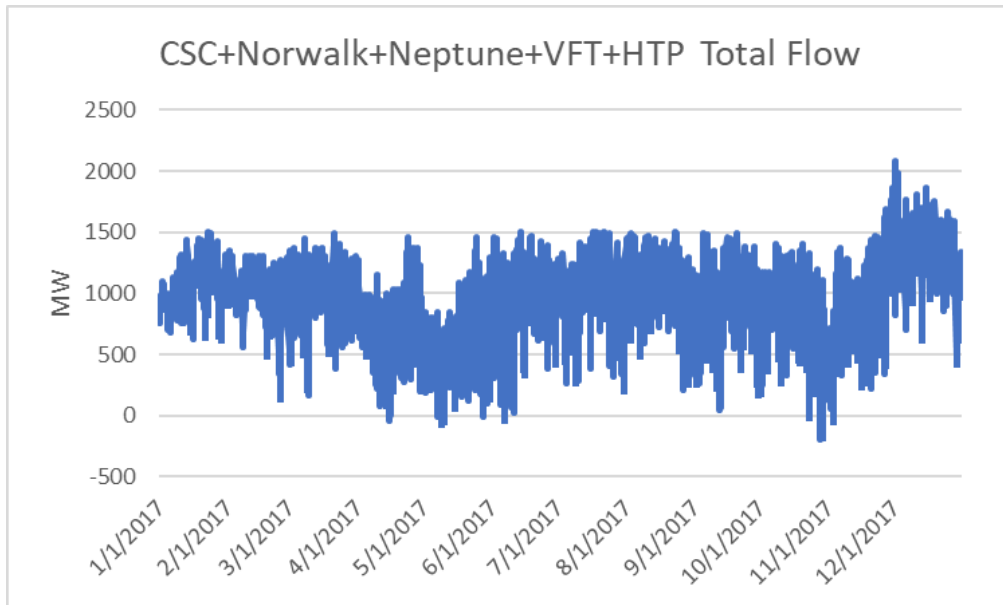

Figure 48. Sum of CSC + Norwalk + Neptune + VFT + HTP Interface Flow Profiles



The contingency set studied is outlined in the 2018 NYISO summer operating study.¹² Finally, in addition to the generator additions mentioned in the Gold Book, a worst-case scenario approach is simulated with the assumed addition of additional renewable penetration, particularly in Zones J and K. All internal NYISO interfaces, constrained elements per constraint as well as all CHG&E 345 kV lines are monitored (see Table 26).

Table 26. Contingency-Monitored Element Pairs Modeled

Contingency	Constraint
Packard-Niagara (62) 230 Packard-Beck 230	Niagara-Packard (61) 230
Athens- Pleasant Valley 345	Leeds-Pleasant Valley 345
Sprain Brook-East Garden City 345 Sprain Brook-Academy 345	Dunwoodie-Shore Road 345
Mott Haven-Rainey 345 (Q12) Rainey 345/138 Rainey-East 75th Street 138	Mott Haven-Rainey 345 (Q11)
Leeds- New Scotland 345 (94)	Leeds- New Scotland 345 (93)
Marcy-Frasers Series Cap	Frasers-Coopers Corners 345
Rock Tavern-Roseton 345 Rock Tavern-Middletown Tap 345 Coopers Corners-Middletown Tap 345 Middletown 345/138	Rock Tavern-Dolson Ave 345
Rock Tavern-Dolson Ave 345	Coopers Corners-Middletown Tap 345
Chateauguay-Massena 765 Massena-Marcy 765	Moses-Adirondack 230 Browns Falls-Taylorville 115
Marcy 765/345 T1	Marcy 765/345 T2
Marcy-Frasers Series Cap Chases Lake- Porter 230	Marcy-Edic 345

The simulation results show that the Central East interface is binding for 1562 hours. Further binding constraints under the contingencies modeled include Packard-Niagara (230 kV, 61 hours), Pleasant Valley-Leeds (345 kV, 62 hours), Mott Haven-Rainey (345 kV, 128 hours) and the Marcy transformer (765/345 kV, 349 hours). These lines, however, are not located in the CHG&E territory (neither the individual lines nor the lines making up the Central East interface). Therefore, the analysis is repeated by focusing on even more severe constraints in the 345-kV system. In particular, the N-1-1 contingency

of 345 kV Athens–Pleasant Valley and 345 kV Leeds–Pleasant Valley¹³ is modeled. For the loss of this right-of-way, the corresponding monitored element is the 345 kV CHG&E line Leeds–Hurley. The latter line binds for 160 hours for the loss of the Pleasant Valley lines. Changes in other binding constraints include the Packard–Niagara 230 kV (that now binds for 69 hours), Mott Haven–Rainey 345 kV (binding for 130 hours), and the Marcy transformer (that now binds for 339 hours).

8.2.3 Energy Storage Siting

For the purposes of alleviating congestion and suppressing the corresponding price separation, the optimal locations for storage are determined with the same logic and methodology as the optimal locations for the PV integration use case.

Table 27. Top Five Discharging Sites for Congestion Relief Use Case

Bus Number	Bus Name
125030	HURLEY 1
125034	LINCOLN
125023	E.KINGST
125035	LR CBLTP
125104	HURLEY 6

There are no buses within CHG&E’s sub-transmission system where storage charging can alleviate the congestion of Leeds–Hurley. As expected, buses on the 345kV CHG&E transmission network will be more impactful in the reduction of the congestion with storage injections. For example, Hurley 345kV is the optimal location for discharging. (As a reference, Leeds 345kV [National Grid] is the optimal location for charging.) Lastly, buses that are electrically equivalent have not been considered (e.g., all Athens buses are equally good charging locations).

8.2.4 Energy Storage Sizing

Previous studies have determined that the mitigation of congestion to 100% with storage is hardly ever economical. This is verified by very large necessary storage sizes resulting from the simulated methodology as described previously. By editing the constraint that enforces the maximum on the monitored line flows, the model can capture “hybrid” storage solutions where only some of the congestion is mitigated. Such solutions may end up having a preferable benefit-cost ratio to full congestion mitigation, due to the non-linear evolution of battery costs with battery MW and MWh sizes.

Table 28 provides the storage location and its corresponding size for different levels of congestion (i.e., the percentage shown is the percentage of congestion mitigated). The table stops at 70% of congestion decrease, which corresponds to 137.4 MW of storage needed. Larger battery sizes needed to alleviate congestion to more than 70% cannot be accommodated on many sub-transmission buses.

Table 28. Battery Sizes for Different Levels of Congestion Mitigation

Percentage of Congestion Decrease	Bus Name	Storage Size (MW)
10	HURLEY 1	19.6
20	HURLEY 1	39.3
30	HURLEY 1	58.9
50	HURLEY 1	98.2
70	HURLEY 1	137.4

The flow on the monitored line is 1,477.6 MW. Using 1,396 MW as a reference for the line rating (actual line rating may differ), the line loading translates to an overload of 81.6 MW for an N-1-1 outage of the Pleasant Valley–Leeds and Pleasant Valley–Athens lines. The outage transfer distribution factor of Hurley 1 is 0.4157. Therefore, an injection of 137.4 MW decreases the flow on the Leeds–Hurley line by 57.12 MW (i.e., 0.4157×137.4), which is 70% of the 81.6 MW of overload. The result of the optimization problem for the other allowable line limits/congestion decrease levels shown in Table 28 can similarly be verified to reduce the flow on the congested line.

Note that the optimal battery size for 100% congestion mitigation would be 147.1 MW if the battery were located at the Hurley 345kV bus—significantly lower than when we focus on CHG&E’s sub-transmission only. We concluded that necessary storage sizes are large due to narrowing down the possible locations to (1) just the CHG&E territory and (2) to the sub-transmission system.

8.2.5 Benefit-Cost Analysis

For the BCA results in this section, battery energy storage is assumed to not participate in the energy or ancillary markets. For lack of explicit cost information, the analysis was performed with the traditional investment as a variable, as can be seen in Figure 49.

The MWh requirement of the battery for congestion relief applications is based on the megawatt value determined previously and an ISO-specific market re-dispatch time. For the BCA analysis that follows, this is assumed to be two hours. Figure 49 shows the pretax cash flow and the revenue requirement versus the traditional investment for a 137.4 MW/274.8 MWh battery. The investment in the battery is financially competitive from a revenue requirement perspective for a traditional investment higher than \$264.30 million and is financially competitive from a utility (pretax cash flow) perspective when the traditional investment is higher than \$340.13 million.

Figure 49. Revenue Requirement (Ratepayer) and Pretax Cash (Utility) Flow—Hurley

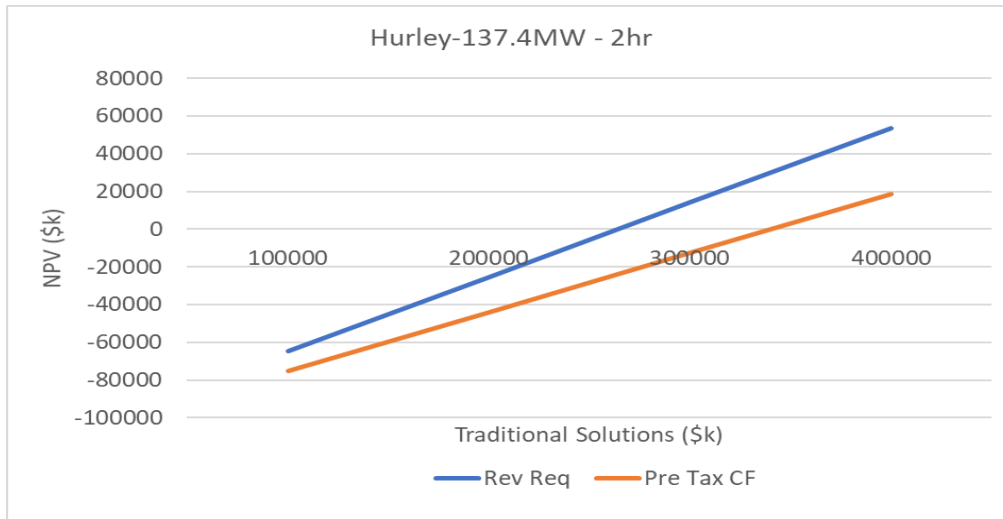

8.3 Capacity Deferral at Sub-transmission System

8.3.1 Input Data and Assumptions

Needed inputs for this use case include:

1. Sub-transmission lines of interest listed as capital projects in the sub-transmission part of the grid were used.
2. Converged PSSE model of the 2018 summer peak study case.
3. 8760-hour historical load and forecasted peak (MWs) available in CHG&E’s GIS portal.

The capital cost of a traditional (wired) solution is considered sensitive information, therefore, the following assumptions were made:

- Deferral period/desired mitigation is five years.
- Battery storage financials were analyzed using traditional cost as a variable.

8.3.2 Screening Process

None of the lines in the five groups of lines in the announced planned projects by CHG&E are loaded close to their MVA design limit. However, an outage of the Saugerties–Woodstock line will island parts of the system. In particular, the island created by the outage of Saugerties–Woodstock has a 17.5 MW/1.1 MVar load. Note that the following analysis uses the Saugerties–Woodstock line since it is near to the Saugerties–North Catskill line listed in CHG&E’s planned project (the flow goes North Catskill–Cements–Saugerties–Woodstock). It must be noted, however, that capacity deferral for this line is used only as an example and that CHG&E has no current plans to rebuild the Saugerties–Woodstock line. Load restoration for loss of this line is performed via distribution switching.

8.3.3 Energy Storage Siting

For the potential outage of line Saugerties–Woodstock, the location for storage should be at Woodstock (125143).

8.3.4 Energy Storage Sizing

For the sizing application, we assumed an average of 24 hours outage time. Results with varying MW sizes and a fixed MWh size are reported for the outage of the Saugerties–Woodstock line. Note that since the peak of the load in the island created by this outage is 17.5 MW, a 17.5 MW battery is the highest that should be considered for installation. The results with a 10 MW/250 MWh battery at Woodstock are shown in Figure 50; note that this size battery could not carry the entire island at peak demand.

Figure 50. Minimum Backup, Outage at Saugerties–Woodstock Line, ESS at Woodstock, 10 MW/250 MWh

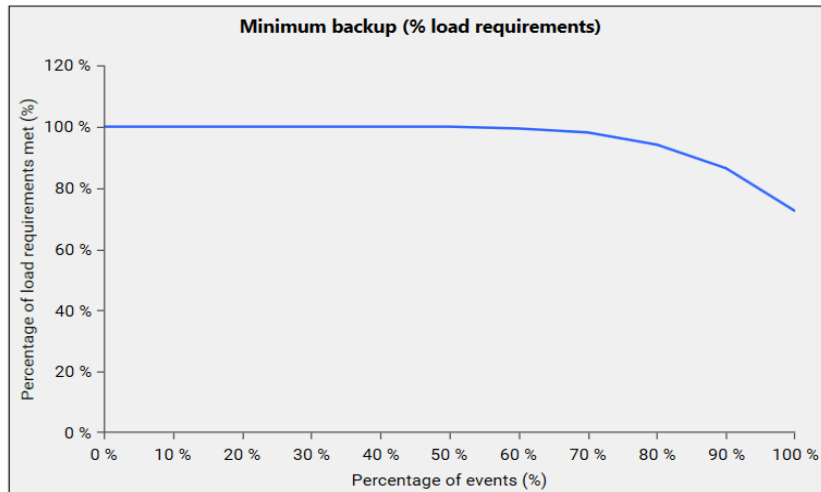

The results with a 17.5 MW /250 MWh battery at Woodstock are shown in Figure 51.

Figure 51. Minimum Backup, Outage at Saugerties–Woodstock Line, ESS at Woodstock, 17.5 MW/250 MWh

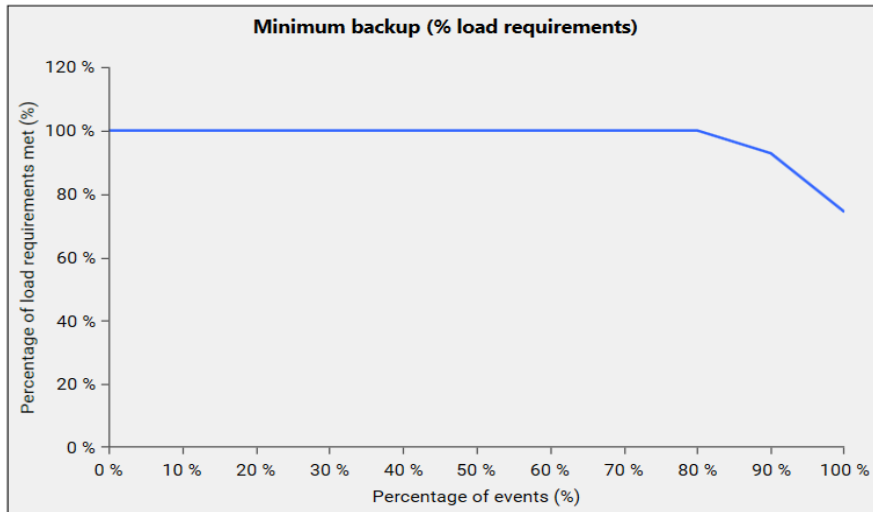

The results with a 17.5 MW/150 MWh battery at Woodstock are shown in Figure 52.

Figure 52. Minimum Backup, Outage at Saugerties–Woodstock Line, ESS at Woodstock, 17.5 MW/150 MWh

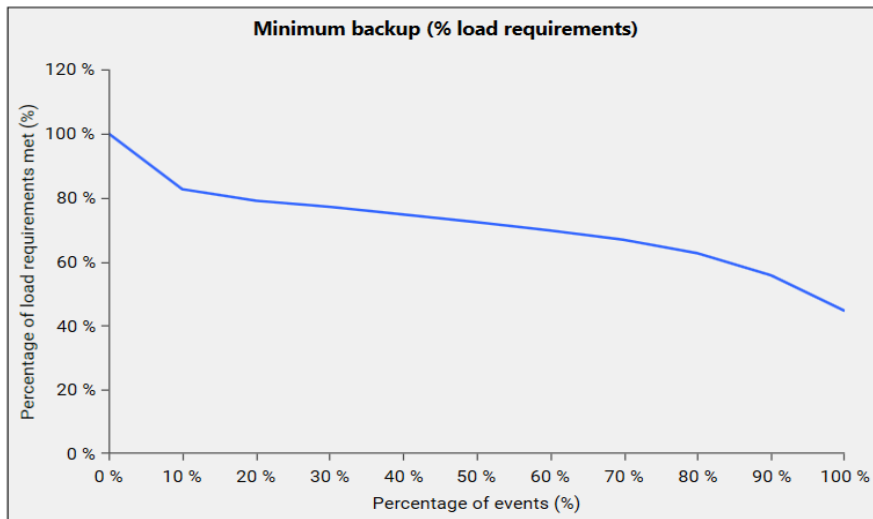

The results with a 17.5 MW/350 MWh battery at Woodstock are shown in Figure 53. Note that the maximum 24-hour sum of loads is 329 MWh; therefore, MWh values higher than that will result in meeting all the load for all events.

Figure 53. Minimum Backup, Outage at Saugerties–Woodstock line, Energy Storage System at Woodstock, 17.5 MW/350 MWh

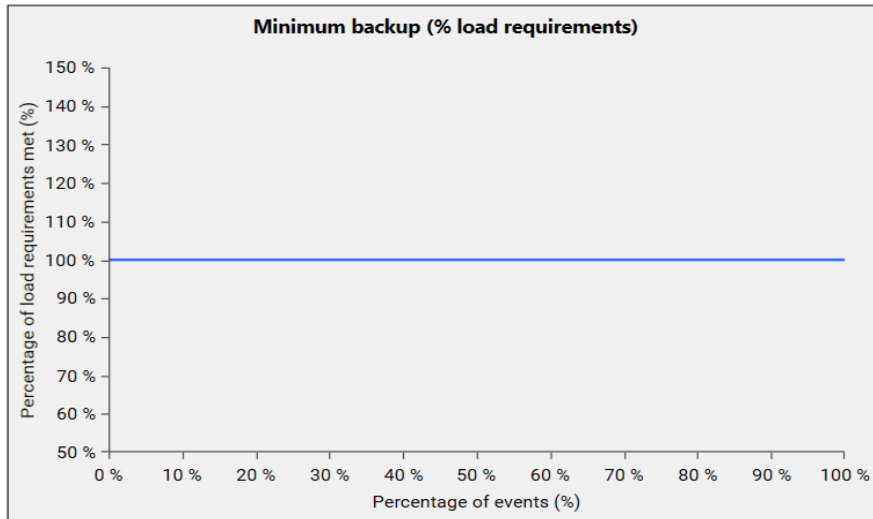

8.3.5 Benefit-Cost Analysis

For the BCA results in this section, battery energy storage is assumed to not participate in the energy or ancillary markets. For lack of explicit cost information, the analysis was performed with the traditional investment as a variable, as seen in Figure 54.

Figure 54 shows the pretax cash flow and the revenue requirement versus the traditional investment for a 17.5 MW/250 MWh battery. The investment in the 17.5 MW/250 MWh battery is financially competitive from a revenue requirement perspective for a traditional investment higher than \$209 million and is financially competitive from a utility (pretax cash flow) perspective when the traditional investment is higher than \$281 million.

Figure 54. Revenue Requirement (Ratepayer) and Pretax Cash (Utility) Flow, 17.5 MW/250 MWh

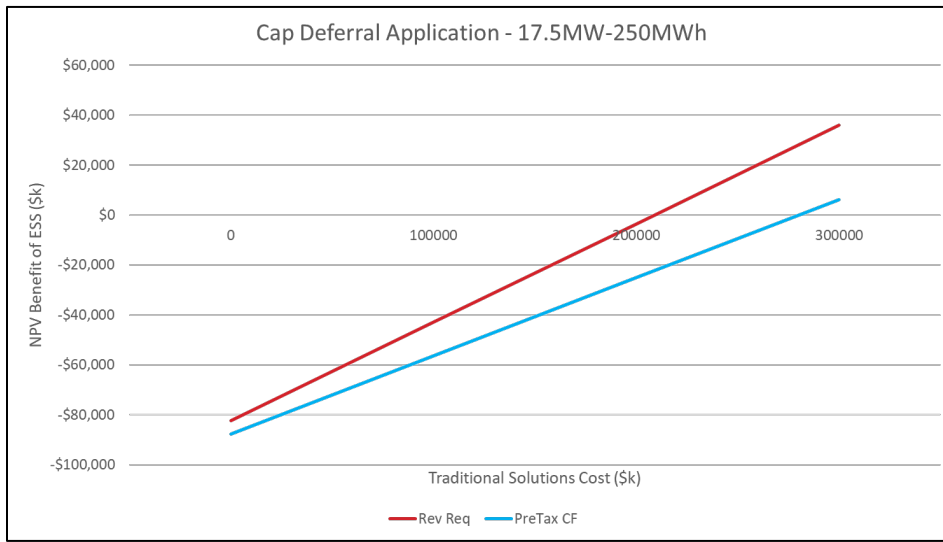

9 References

- H.L. Willis, H.N. Tram, R.W. Powell, “A Cluster-Based Method of Building Representative Models of Distribution System,” IEEE Transactions on Power Apparatus and Systems, March 1983, p. 1776.
- State of New York, Public Service Commission, “Case 18-E-0130-In the Matter of Energy Storage Deployment Program. Order Establishing Energy Storage Goal and Deployment Policy,” December 13, 2018.
- New York Independent System Operator, “2017 CARIS (Congestion Assessment and Resource Integration Studies) Report”, February 2018,
https://www.nyiso.com/documents/20142/1402648/05_CARIS2017_Report.pdf
- New York Independent System Operator, “2017 Load & Capacity Data Gold Book,” April 2017,
<https://www.nyiso.com/documents/20142/2226333/2017-Load-Capacity-Data-Report-Gold-Book.pdf/8f9d56cc-dc20-0705-ca19-52e35a535b44>
- New York Independent System Operator, “NYISO Operating Study Summer 2018”, June 2018,
<https://www.nyiso.com/documents/20142/3691300/Summer2018-Operating-Study.pdf/8c584dda-ca89-3a8e-0b5a-036926c1f994>
- New York Independent System Operator, Energy Market and Operational data, Accessed December 4, 2020, <https://www.nyiso.com/energy-market-operational-data>
- New York Independent System Operator, Interconnection process, Accessed December 4, 2020,
<https://www.nyiso.com/interconnections>
- Joint Utilities of New York, Accessed December 4, 2020, <https://jointutilitiesofny.org/>
- Central Hudson, Geographic Information Systems, Accessed December 4, 2020,
<https://gis.cenhud.com/gisportal/home/>
- U.S. Energy Information Administration, Short-term energy outlook, Accessed December 4, 2020,
<https://www.eia.gov/outlooks/steo/>
- National Renewable Energy Laboratory, “PVWatts Calculator”, Accessed December 4, 2020,
<https://pvwatts.nrel.gov/>

Endnotes

- ¹ The hourly day-ahead market Locational Based Market Price at the delivery point.
- ² NESC® = National Electrical Safety Code®; NPCC = Northeast Power Coordinating Council, Inc.; NYSRC = New York State Reliability Council, LLC.
- ³ Note that as soon as the ESS participates in an NYISO market, the facility it is connected to becomes FERC jurisdiction for interconnection.
- ⁴ On December 3, 2018, NYISO made a compliance filing in response to FERC Order 841 designed to facilitate greater participation by electric ESS resources in organized wholesale electric markets. The NYISO filing will require telemetry of resources state-of-charge to allow the NYISO to effectively monitor the resources' performance and align the scheduling decisions with the resources' physical capabilities to respond.
- ⁵ see 18-E-0130—In the Matter of Energy Storage Deployment Program, Utility Roles.
- ⁶ New York State, Department of Public Service. Hosting Capacity Maps and Useful Links:
<http://www3.dps.ny.gov/W/PSCWeb.nsf/All/6143542BD0775DEC85257FF10056479C?OpenDocument>
- ⁷ H.L. Willis, H.N. Tram, R.W. Powell, "A Cluster-Based Method of Building Representative Models of Distribution System," IEEE Transactions on Power Apparatus and Systems, March 1983, p. 1776.
- ⁸ Other possibilities for stacked applications, based on the interconnection level of ESS (transmission versus distribution), are described in ESselect and ESSVET platforms.
- ⁹ Note that these dates were taken from the NYISO queue. As of September 2020, none of these sites were in service.
- ¹⁰ Please see <https://pvwatts.nrel.gov/>
- ¹¹ Positive values are flows into NYCA.
- ¹² <https://www.nyiso.com/documents/20142/3691300/Summer2018-Operating-Study.pdf/8c584dda-ca89-3a8e-0b5a-036926c1f994>
- ¹³ The contingency Athens-Pleasant Valley or Leeds-Pleasant Valley, included in the NYISO Summer 2018 Operating Study, are much less severe contingencies than the complex one proposed here.

NYSERDA, a public benefit corporation, offers objective information and analysis, innovative programs, technical expertise, and support to help New Yorkers increase energy efficiency, save money, use renewable energy, and reduce reliance on fossil fuels. NYSERDA professionals work to protect the environment and create clean-energy jobs. NYSERDA has been developing partnerships to advance innovative energy solutions in New York State since 1975.

To learn more about NYSERDA's programs and funding opportunities, visit nyserdera.ny.gov or follow us on Twitter, Facebook, YouTube, or Instagram.

**New York State
Energy Research and
Development Authority**

17 Columbia Circle
Albany, NY 12203-6399

toll free: 866-NYSERDA
local: 518-862-1090
fax: 518-862-1091

info@nyserdera.ny.gov
nyserdera.ny.gov



NYSERDA

State of New York

Andrew M. Cuomo, Governor

New York State Energy Research and Development Authority

Richard L. Kauffman, Chair | Doreen M. Harris, Acting President and CEO